

Instrument manual

Transmitter in field housing PR 5230



Translation of the original instrument manual

9499 050 52300

Edition 11.11.0

10/20/2023

Release 3.60.xx

Foreword

Must be followed!

Any information in this document is subject to change without notice and does not represent a commitment on the part of Minebea Intec unless legally prescribed. This product should only be operated/installed by trained and qualified personnel. In correspondence concerning this product, the type, name, and release number/serial number as well as all license numbers relating to the product have to be cited.

Note

This document is partially protected by copyright. It may not be changed or copied, and it may not be used without purchasing or written permission from the copyright owner (Minebea Intec). The use of this product constitutes acceptance by you of the abovementioned provisions.

Table of contents

1	Introduction	8
1.1	Read the manual	8
1.2	This is what operating instructions look like	8
1.3	This is what lists look like	8
1.4	This is what menu items and softkeys look like	8
1.5	This is what the safety instructions look like	8
1.6	Hotline	9
2	Safety instructions	10
2.1	General notes	10
2.2	Intended use	10
2.3	Initial inspection	10
2.4	Before operational startup	10
2.4.1	Installation	11
2.4.2	Opening the device	11
2.4.3	Supply voltage connection	11
2.4.4	Protective ground connection	12
2.5	RF interference suppression	12
2.6	Failure and excessive stress	12
2.7	Important note	12
2.8	Repairs and maintenance	13
2.8.1	General information	13
2.8.2	Electrostatically sensitive parts	13
2.8.3	Replacing fuses	13
3	Device description	14
3.1	General notes	14
3.2	Overview of the device	14
3.2.1	Communication protocols	15
3.3	Housing	15
3.3.1	General notes	15
3.3.2	Dimensions	16
3.4	Display and operating elements	16
3.4.1	General information	16
3.4.2	Overview	17
3.4.3	Display	17
3.4.4	Operating elements	23
3.5	Overview of connections	28
3.5.1	Plug-in cards	29
3.6	Device variants	29
3.6.1	Combinations for options	29

4	Device installation.....	31
4.1	General notes.....	31
4.2	Mechanical preparation.....	31
4.2.1	General information.....	31
4.2.2	Cable gland.....	32
4.2.3	Cabling.....	32
4.2.4	Installation of a cable.....	33
4.3	EMC-compliant installation.....	34
4.3.1	Connecting the screens.....	34
4.3.2	Connecting the equipotential bonding conductor.....	34
4.4	Hardware construction.....	34
4.4.1	Main board.....	34
4.4.2	Display board.....	36
4.4.3	Weighing electronics board.....	36
4.4.4	Network port.....	38
4.4.5	RS-232 interface.....	40
4.4.6	RS-485 interface.....	44
4.4.7	Digital inputs.....	53
4.4.8	Digital outputs.....	56
4.5	Connection of analog load cells and weighing platforms.....	61
4.5.1	General information.....	61
4.5.2	Connecting a load cell with a 4-wire cable.....	62
4.5.3	Connecting a load cell with a 6-wire cable.....	63
4.5.4	Connecting between 2 and 8 load cells (650 Ω) using a 6-wire connection cable.....	64
4.5.5	Connecting load cells of type series PR 6221.....	65
4.5.6	Testing the measuring circuit.....	65
4.5.7	External supply to load cells.....	66
4.5.8	Connecting 2...4 load cells via PR 5230/22 load cell junction board.....	67
4.5.9	Connecting an analog weighing platform (CAP... series).....	70
4.6	Accessories.....	73
4.6.1	General information.....	73
4.6.2	Analog outputs.....	74
4.6.3	Load cell junction board.....	76
4.6.4	Status LEDs on fieldbus card.....	76
4.6.5	Profibus DP interface.....	76
4.6.6	InterBus-S interface.....	82
4.6.7	DeviceNet interface.....	86
4.6.8	CC-Link interface.....	90
4.6.9	ProfiNet I/O interface.....	92
4.6.10	EtherNet/IP interface.....	96
4.6.11	Ethernet port for PR 5230/30.....	99
4.6.12	Ethernet cable for PR 5230/31.....	100

5	"Standard" application	101
5.1	Functions.....	101
5.1.1	General information	101
5.1.2	Display functions.....	101
6	"EasyFill" application	102
6.1	Functions.....	102
6.1.1	General information	102
6.1.2	Display functions.....	102
6.1.3	Filling mode	102
6.2	Application menu [Start]	102
7	Getting started	104
7.1	Power failure/Data backup/Restart	104
7.1.1	Power failure.....	104
7.1.2	Data backup.....	104
7.1.3	Overwrite protection	104
7.1.4	Restart	106
7.2	Switching on the device.....	106
7.3	Switching off the device	107
7.4	Warm-up time	107
7.5	Finding and connecting a device with a notebook/PC.....	107
7.6	Finding and connecting the device automatically in the network.....	108
7.7	Searching the device in the network with "IndicatorBrowser".....	108
7.8	Resetting the network address	110
7.9	Operation using VNC	111
7.10	Operation via a web browser	112
7.11	System setup.....	113
7.11.1	Serial ports parameter	113
7.11.2	Date & time	114
7.11.3	Operating parameters.....	114
7.11.4	Printing parameter	114
7.11.5	Fieldbus parameter.....	115
7.11.6	Network parameter	115
7.11.7	Weighing points	115
7.11.8	Display items	121
7.11.9	Limit parameter.....	121
7.11.10	Digital I/O parameters	122
7.11.11	Analog output parameter	122
7.12	Calibrating internal weighing point.....	122
7.12.1	General information	122
7.12.2	Displaying calibration data.....	123
7.12.3	Selecting the calibration mode.....	124

7.12.4	Setting maximum load.....	127
7.12.5	Determining the scale interval.....	128
7.12.6	Determining the dead load	128
7.12.7	Calibrating with weight.....	129
7.12.8	Calibrating with mV/V.....	131
7.12.9	Calibrating with load cell data (smart calibration).....	133
7.12.10	Subsequent dead load correction	134
7.12.11	Linearization	135
7.12.12	Calculating the test value	138
7.12.13	Saving the calibration.....	138
7.12.14	Cancelling a calibration.....	139
7.12.15	Parameter Input.....	140
7.13	Calibrating xBPI-scale.....	145
7.13.1	General information	145
7.13.2	Parameters for serial interface	145
7.13.3	Parameters for the xBPI-weighing function.....	147
7.13.4	Setting up an xBPI platform.....	148
7.13.5	xBPI-parameter tables.....	150
7.13.6	Setting the xBPI dead load	154
7.13.7	xBPI calibration with user specified weight.....	155
7.13.8	xBPI calibration with automatic weight detection	156
7.13.9	xBPI calibration with default weight.....	157
7.13.10	xBPI calibration with built-in weight	158
7.13.11	xBPI linearization	159
7.14	Calibrating digital load cells of type "Pendeo"	160
7.14.1	General information	160
7.14.2	Selecting and configuring RS-485 interface	161
7.14.3	Selecting the load cell type	162
7.14.4	Calibration procedure	162
7.14.5	Searching load cells	162
7.14.6	Assigning load cells	165
7.14.7	Calibrating load cells	166
7.14.8	Assigning load cell names	168
7.14.9	Service function.....	168
7.14.10	Corner correction.....	170
7.14.11	Terminating/saving calibration	171
7.14.12	Parameter Input.....	171
7.14.13	Subsequent dead load correction	173
7.14.14	Displaying weighing point serial number	174
7.15	General parameter settings	174
7.15.1	Selecting and configuring serial interfaces	175
7.15.2	Date and time	183

7.15.3	Operating parameters.....	184
7.15.4	Print parameters	185
7.15.5	Fieldbus parameters.....	187
7.15.6	Network parameters.....	191
7.15.7	Configuring display	192
7.15.8	Configuring limit values.....	192
7.15.9	Configuring digital inputs.....	198
7.15.10	Configuring digital outputs.....	201
7.15.11	Display of limits and digital inputs/outputs.....	205
7.15.12	Configuring analog output.....	205
7.16	System information.....	207
7.16.1	Displaying the version.....	207
7.16.2	Displaying the status.....	208
7.16.3	Showing hardware options	209
7.16.4	Displaying Pendeo data.....	210
8	Production	213
8.1	General notes	213
8.2	Starting the application	213
8.3	Configuration via a notebook/PC	214
8.3.1	Configuring production mode	214
8.3.2	Configuring digital inputs and outputs.....	217
8.3.3	Configuring material	219
8.3.4	Configuring printout	221
8.4	Filling	223
9	Extended functions	225
9.1	Hardware test.....	225
9.1.1	Serial interfaces.....	225
9.1.2	Inputs and outputs	227
9.2	Functions via the WEB site	232
9.2.1	General information	232
9.2.2	Displaying weighing points in a table.....	232
9.2.3	Configuration printout	233
9.2.4	Log files	235
9.2.5	Screenshots.....	237
9.2.6	Error log.....	238
9.2.7	Event memory	239
9.2.8	Configuration data.....	241
9.3	Resetting the device to the factory settings	242
9.4	Updating new software with FlashIt.....	243
9.4.1	Updating in network with a DHCP service	243
9.4.2	Updating via a point-to-point connection with DHCP service	245

9.4.3	Updating with a fixed IP address	247
10	ModBus protocol	250
10.1	General description	250
10.2	SPM data in PR 1612 ModBus mode	250
11	SMA protocol	252
11.1	General information	252
12	Fieldbus interface	253
12.1	General notes	253
12.2	Scale protocol (8-byte) for the "Standard" application	253
12.2.1	Data exchange range	254
12.2.2	Reading and writing data with function numbers	256
12.2.3	Reading and writing bits directly	258
12.2.4	Waiting for the result of the action	258
12.2.5	Function numbers	259
12.2.6	Example: reading the gross weight	264
12.2.7	Special note for DeviceNet and EtherNet IP	265
12.3	Filling protocol (64-Byte) for the "EasyFill" application	265
12.3.1	Write window (input area)	265
12.3.2	Read window (output area)	265
12.3.3	Indicator functions	266
12.3.4	Filling functions	266
12.3.5	Setup of the fieldbus interface	268
13	SPM	274
13.1	General information	274
13.2	Elementary data types	274
13.3	Addressing	275
13.4	System data	275
14	Maintenance/repairs/soldering work/cleaning	281
14.1	Maintenance	281
14.2	Repairs	281
14.2.1	Battery for date/time	281
14.2.2	Changing the battery for date/time	281
14.3	Soldering work	282
14.4	Cleaning	282
15	Disposal	283
16	Error messages	284
16.1	Error messages measuring circuit	284
16.2	Weight error status	285
16.3	Error messages for xBPI scales	285

16.4	Error messages for Pendeo load cells	286
16.5	Error messages during calibration.....	287
16.6	General error messages.....	289
16.7	Error messages for Ex applications	289
16.8	Error numbers @ "LAST_ERROR"	290
16.8.1	Weighing point error	290
16.8.2	Error in the "EasyFill" application	291
17	Technical data	292
17.1	Note on using "free software"	292
17.2	Decoding the serial number.....	292
17.3	General data	292
17.3.1	Backup for date/time	292
17.3.2	Supply voltage connection 230 V AC.....	292
17.3.3	Supply voltage connection 24 V DC.....	293
17.4	Effect of ambient conditions	293
17.4.1	Ambient conditions	293
17.4.2	Electromagnetic Compatibility (EMC).....	293
17.4.3	RF interference suppression	294
17.5	Connecting cables	294
17.6	Mechanics	294
17.6.1	Design.....	294
17.6.2	Weights.....	294
17.7	Documentation on the CD included	294
18	Appendix	295
18.1	Spare parts.....	295
18.1.1	Weighing electronics board	295
18.1.2	Display board.....	295
18.1.3	Fuses/accessory kits.....	296
18.2	Test connector.....	296
18.3	Certificates.....	297

1 Introduction

1.1 Read the manual

- Please read this manual carefully and completely before using the product.
- This manual is part of the product. Keep it in a safe and easily accessible location.

1.2 This is what operating instructions look like

1. - n. are placed before steps that must be done in sequence.
- ▶ is placed before a step.
 - ▷ describes the result of a step.

1.3 This is what lists look like

- indicates an item in a list.

1.4 This is what menu items and softkeys look like

[] frame menu items and softkeys.

Example:

[Start]- [Applications]- [Excel]

1.5 This is what the safety instructions look like

Signal words indicate the severity of the danger involved when measures for preventing hazards are not followed.

DANGER

Warning of personal injury

DANGER indicates death or severe, irreversible personal injury which will occur if the corresponding safety measures are not observed.

- ▶ Take the corresponding safety precautions.

WARNING

Warning of hazardous area and/or personal injury

WARNING indicates that death or severe, irreversible injury may occur if appropriate safety measures are not observed.

- ▶ Take the corresponding safety precautions.

CAUTION

Warning of personal injury.

CAUTION indicates that minor, reversible injury may occur if appropriate safety measures are not observed.

- ▶ Take the corresponding safety precautions.

NOTICE**Warning of damage to property and/or the environment.**

NOTICE indicates that damage to property and/or the environment may occur if appropriate safety measures are not observed.

- ▶ Take the corresponding safety precautions.
-

Note:

User tips, useful information, and notes.

1.6 Hotline

Phone: +49.40.67960.444

Fax: +49.40.67960.474

eMail: help@minebea-intec.com

2 Safety instructions

2.1 General notes

CAUTION

Warning of personal injury.

This device has been built and tested in compliance with the safety regulations for measuring and control equipment for protection class I (protective grounding conductor) according to IEC 1010/EN 61010 or VDE 0411.

The device was in perfect condition with regard to safety features when it left the factory.

- ▶ To maintain this condition and to ensure safe operation, the user must follow the instructions and observe the warnings in this manual.

2.2 Intended use

The device is intended for use of the analysis device for weighing functions.

Product operation, commissioning and maintenance must be performed by trained and qualified personnel who are aware of and able to deal with the related hazards and take suitable measures for self-protection.

The device reflects the state of the art.

No warranty is given that the product is free of faults, especially not in conjunction with third-party software and hardware components required for operation.

The manufacturer does not accept any liability for damage caused by third-party system components or due to incorrect use of the product. The use of this product signifies recognition of the stipulations listed above.

2.3 Initial inspection

Check the contents of the consignment for completeness. Check the contents visually to determine whether any damage has occurred during transport. If there are grounds for rejection of the goods, a claim must be filed with the carrier immediately. The Minebea Intec sales or service organization must also be notified.

2.4 Before operational startup

NOTICE

Perform visual inspection.

- ▶ Before operational startup as well as after storage or transport, inspect the device visually for signs of mechanical damage.

2.4.1 Installation

The device has to be installed in an EMC-compliant manner, see Chapter 4.3.

The housing of the device complies with IP65.

Mount the device with the cable glands pointing downwards.

To ensure proper cooling of the device, make sure air circulation around the device is not blocked. Avoid exposing the instrument to excessive heat, e.g. from direct sunlight, and vibrations. The ambient conditions in Chapter 17.4.1 must be taken into account at all times.

With outdoor mounting, make sure that adequate weather protection is provided (for temperatures, see Chapter 17.4.1).

2.4.2 Opening the device

⚠ WARNING

Working on the device while it is switched on may have life-threatening consequences.

When removing covers or parts using tools, live parts or terminals may be exposed. Please note that capacitors in the device may still be charged even after disconnecting the device from all voltage sources.

► Disconnecting the device from the power supply.

This device contains electrostatically sensitive components. For this reason, an equipotential bonding conductor must be connected when working on the open device (antistatic protection).

2.4.3 Supply voltage connection

The device does not have a power switch. It is in operation as soon as the power is connected.

2.4.3.1 Version 230 V AC



Safe interruption of both supply voltage conductors must be provided for, either by disconnecting the power connector or using a separate switch.

The device is equipped with a wide range power supply and covers AC systems with a frequency of 50/60 Hz and a voltage range of $U_{AC} = 100$ to 240 V $-15/+10\%$ automatically (without manual selection).

The power supply is protected against short circuits.

2.4.3.2 Version 24 V DC



This version is designed for $U_{DC} = 24\text{ V}$.

The supply is established via a 3-pin plug connection (PE/+/-). The device is protected against incorrect polarity.

The device is protected via internal fuses in the + and - line (primary side).

2.4.4 Protective ground connection

2.4.4.1 Version 230 V AC

The device must be connected to a protective ground via a protective grounding conductor (PA) in the network plug.

The power cable contains a protective grounding conductor which must not be interrupted inside or outside the device.

The protective grounding conductor is connected to the device in the housing.

2.4.4.2 Version 24 V DC

The device must be connected to the protective grounding conductor. The connection can be established via the housing side panel.

2.5 RF interference suppression

The device is intended for use in an industrial environment. Operation of this device in a residential environment is likely to cause radio frequency interference, see Chapter [17.4.3](#). In this case, the operator may be required to take appropriate measures.

2.6 Failure and excessive stress

If there is any reason to assume that safe operation of the device is no longer ensured, shut it down and make sure it cannot be used.

Safe operation is no longer ensured if any of the following is true:

- The device is physically damaged.
- The device does not function.
- The device has been subjected to stresses beyond the tolerance limits (e.g., during storage or transport).

2.7 Important note

Make sure that the construction of the device is not altered to the detriment of safety. In particular, leakage paths, air gaps (of live parts) and insulating layers must not be reduced.

Minebea Intec cannot be held responsible for personal injury or property damage caused by a device repaired incorrectly by an operator or installer.

2.8 Repairs and maintenance

2.8.1 General information

Repairs are subject to inspection and must be carried out at Minebea Intec.

In case of defect or malfunction, please contact your local Minebea Intec dealer or service center for repair.

When returning the device for repair, please include a precise and complete description of the problem.

Maintenance work may only be carried out by a trained technician with expert knowledge of the hazards involved and the required precautions.

2.8.2 Electrostatically sensitive parts

This device contains electro-statically sensitive components. Therefore, potential equalization must be provided when working on the device (antistatic protection).

2.8.3 Replacing fuses

2.8.3.1 Changing fuses with option Y2/WE1

⚠ WARNING

Explosion possible if replacement is not done correctly!

- ▶ The replacement of fuses is not permitted!
- ▶ It is only permitted to replace fuses in the when used in the ex area, if the atmosphere is not potentially explosive.

2.8.3.2 Replacing fuses without option Y2/WE1

⚠ WARNING

Damage from overheating.

The use of repaired fuses and bypassing the fuse holder is prohibited.

- ▶ Only the fuses listed in chapters [17.3.2](#) and [17.3.3](#) are permissible.

3 Device description

3.1 General notes

The instrument is equipped with a 128 x 64 pixel display. It allows for weight values with max. 6 digits and additional status display.

The instrument contains two applications:

- Default
- EasyFill

Most functions are supported by both applications.

A few functions are application-dependent.

3.2 Overview of the device

- Accuracy 10,000 e (class III) for the weighing electronics
- High-speed conversion with measurement times from 5 msec
- Weight display with status by monochrome 128 x 64 pixel display
- 3 function keys in the housing
- IP65 enclosed stainless steel wall housing
- LAN adapter with 10/100 Mbit/s for data transfer, calibration, parameterization
- Integrated RS-232 interface for, e.g., printer or remote display
- Integrated RS-485 interface for, e.g., PC, xBPI scales
- Can be expanded using the following plug-in cards (3 slots):
 - Analog output card PR 5230/06
 - Load cell junction board PR 5230/22
 - Fieldbus cards PR 1721/4x
- 3 opto-decoupled outputs (optional)
- 3 configurable relay outputs with change-over contact
- 3 configurable optocoupler inputs, potential-free internal supply possible (optional) - interfaces
- Electrically isolated interfaces (except RS-232)
- Wide range power supply for $U_{AC} = 100$ to 240 V, protection class I (protective grounding conductor)
- Version for $U_{DC} = 24$ V
- Version with intrinsically safe load cell supply (optional)
- Plug-in connections inside the device for load cells, inputs/outputs, LAN adapter, serial interfaces
- Calibration using PC tool (browser/VNC)
- Calibration using weights according to the mV/V method or directly using load cell data (smart calibration)
- Software configuration of the interface cards, e.g., for remote display or printer

- The "EasyFill" application allows for quick and reliable filling and emptying of vessels (for functional description, see Chapter [6.1](#)).
- Analog test for the weighing electronics
- Overwrite protection using CAL switch on the load cell junction board

3.2.1 Communication protocols

For the internal RS-232 or RS-485:

- Remote display protocol
- Printer
- ModBus-RTU (slave)
- SMA protocol
- xBPI protocol
- EW-Com protocol

Field bus slave (accessories):

- PR 1721/41 ProfiBus DP
- PR 1721/42 InterBus-S
- PR 1721/44 DeviceNet
- PR 1721/45 CC-Link
- PR 1721/46 ProfiNet I/O
- PR 1721/47 EtherNet-IP

For the internal LAN:

- ModBus-TCP
- Ethernet TCP/IP
- OPC-UA, refer to the corresponding documentation

3.3 Housing

3.3.1 General notes

The transmitter is installed in a stainless steel field housing with protection class IP65. It is intended for wall mounting, which is installed to the left forward to the opening door.

The ambient conditions specified for the instrument must be observed (see Chapter [17.4.1](#)).

The housing is mounted using 4 screws. There are no operating elements on the instrument in the closed housing.

The 128 x 64 pixel display and 6 additional status indicator LEDs are visible through a glass pane in the housing door.

3.3.2 Dimensions

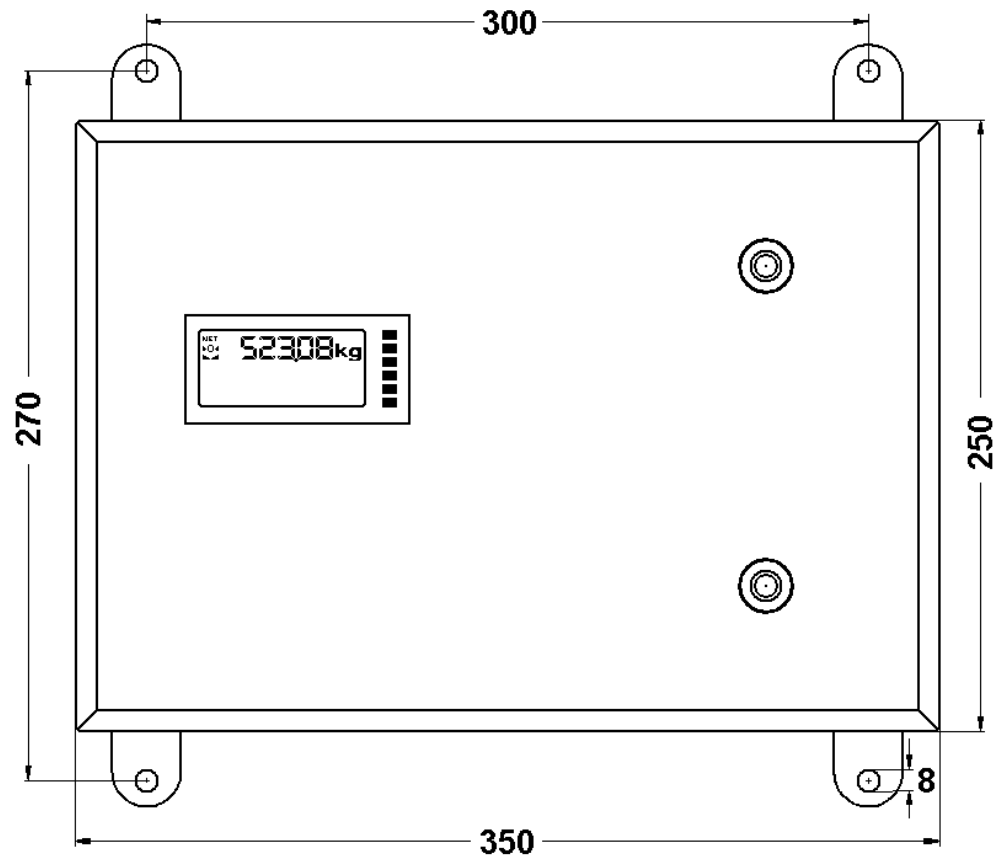

all dimensions in mm
Height = approx. 120 mm

3.4 Display and operating elements

3.4.1 General information

The transmitter in the PR 5230 field housing can only be operated by Notebook/PC.

- VNC viewer (see Chapters [3.4.4.5](#) and [7.9](#)) or
- WEB browser (see Chapter [7.10](#))

3.4.2 Overview

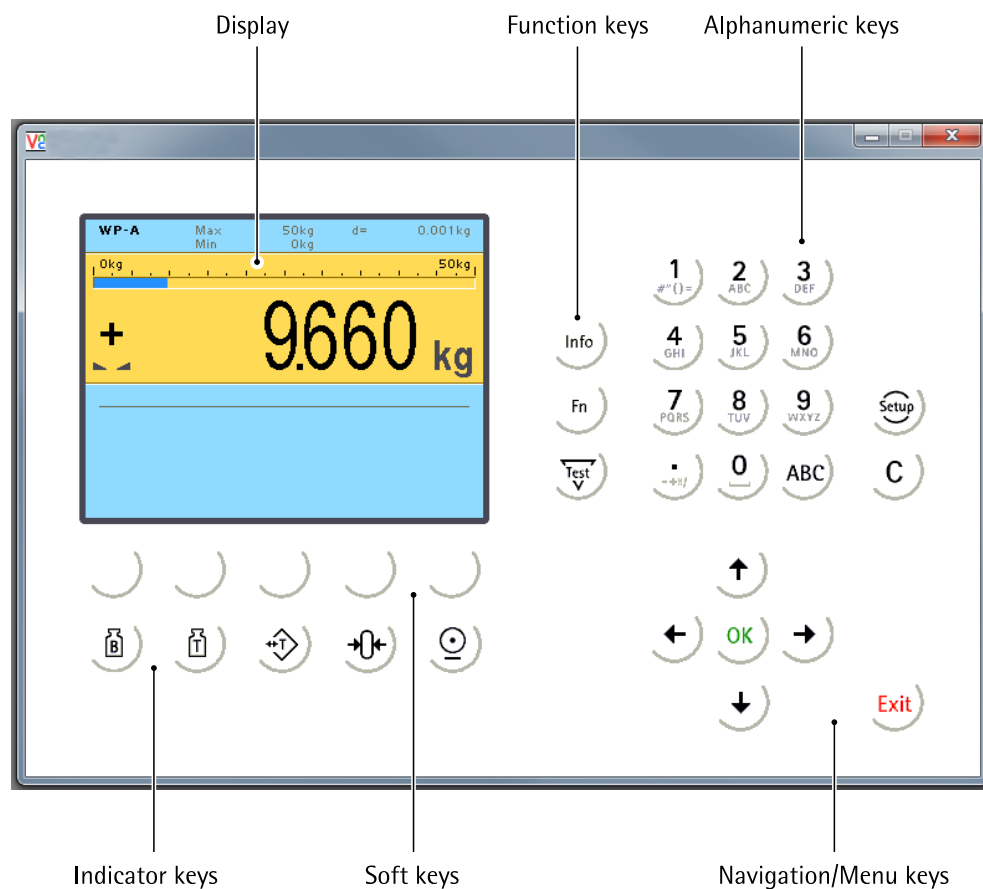

3.4.3 Display

3.4.3.1 User interface

The user interface display can show weight values of up to 7 digits with decimal point and plus or minus sign.



The available mass units are t, kg, g, mg, lb, or oz.

The lb and oz units are not permitted for use in legal metrology in the EU and EEC.

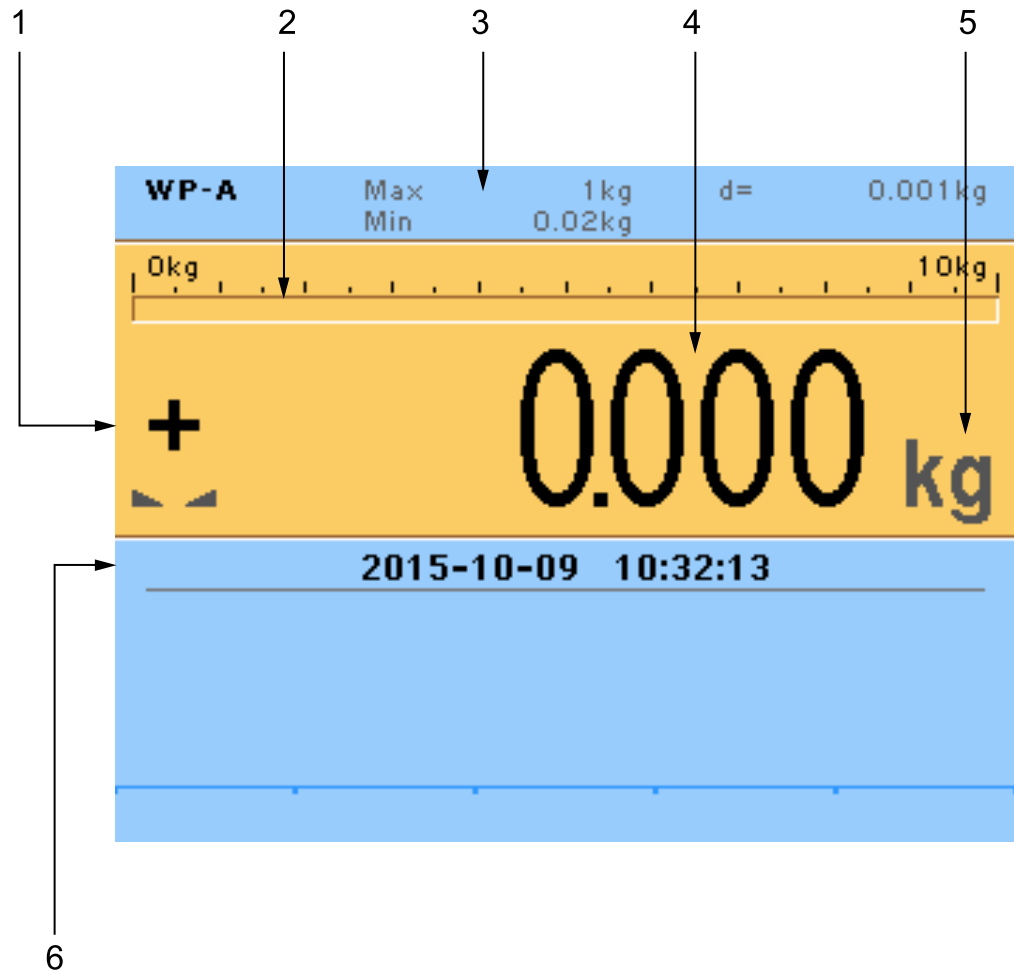
Above the weight display on the user interface, the currently displayed weight is shown in a bar graph that indicates the percentage of the maximum capacity (Max). 0 is on the left, and 100% on the right.



No.	Description
1	Weight type/plus or minus sign/standstill
2	Bar graph
3	Status display
4	Weight value
5	Symbols/mass unit
6	Info line

Weight type/plus or minus sign	Description
B	Gross weight
G	Gross weight in NTEP or NSC mode
NET	Net weight (Net = gross - tare)
T	Tare weight
PT	Preset tare
TST	The weight display shows the test value without mass unit.
No display	- Test value - Gross, not tared
+	Positive value
-	Negative value
<hr/>	
Standstill/zero	Description
	Weight value standstill
→0←	The gross weight value is within $\pm\frac{1}{4}$ d of zero
	Batching mode: flashes when batching is "stopped"; rapid flashing indicates "error status"
<hr/>	
Symbols/mass unit	Description
	Value not permissible in legal metrology (e.g., 10x resolution, deactivated load cell)
R1	Range 1
R2	Range 2
R3	Range 3
WPA	Weighing point A
Max	Maximum capacity (weighing range)
Min	Minimum weight
t, kg, g, mg, lb, oz	These mass units are available.



3.4.3.2 Instrument display

6-digit weight values (digit height 18 mm) with the decimal points can be shown on the display.

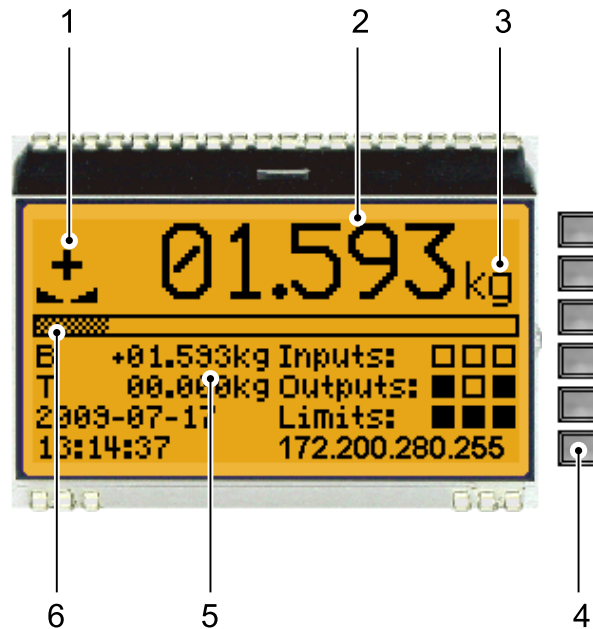
Below the weight display of the instrument, the currently displayed weight is shown in a bar graph that indicates the percentage of the maximum capacity (Max). 0 is on the left, and 100% on the right.



No.	Description
1	Weight type/plus or minus sign/standstill
2	Weight value
3	Symbols/mass unit
4	Status LEDs
5	Status display
6	Bar graph

Weight type/plus or minus sign	Description
B	Gross weight
G	Gross weight in NTEP or NSC mode
NET	Net weight (Net = gross - tare)
T	Tare weight
PT	Preset tare
No display	- Test value - Gross, not tared
TST	The weight display shows the test value without mass unit.
+	Positive value
-	Negative value
Standstill/zero/dosing	Description
	Weight value standstill
→0←	The gross weight value is within $\pm\frac{1}{4}$ d of zero
	Batching mode: flashes when batching is "stopped"; rapid flashing indicates "error status"
Symbols/mass unit	Description
	No verifiable weight (e. g., 10-x resolution, deactivated load cell)
R1	Range 1
R2	Range 2
R3	Range 3
t, kg, g, mg, lb, oz	These mass units are available.

3.4.3.3 Status display







For status indication on the device display, max. 5 lines can be configured by selecting from a menu (see Chapter [7.15.7](#)).

Selection	Width	Height	Example	Description
Empty	½ Display	1 line		Blank
Gross/Net/Tare	½ Display	1 line	B +123.45 kg E:Sense	Gross/Net/Tare Error, see Chapter 16.1
Gross	½ Display	1 line	B +123.45 kg	Gross
Net	½ Display	1 line	NET +123.45 kg	Net
Tare	½ Display	1 line	T +123.45 kg	Tare
Bar graph	1 display	1 line		Shows the weight in proportion to maximum capacity.
Fieldbus LEDs	½ Display	1 line	--- red --- grn	See Chapter 4.6.5.2 , for example.
Fieldbus inputs	1 display	1 line	FB-Inp: 01.23...CD.EF	Fieldbus inputs
Fieldbus outputs	1 display	1 line	FB-Out: 01.23...CD.EF	Fieldbus outputs
Digital inputs	½ Display	1 line	Inputs: ■■■	Digital inputs: 1, 2, 3
Digital outputs	½ Display	1 line	Outputs: ■■■	Digital outputs: 1, 2, 3
Digital I/O	½ Display	1 line	I: ■■■ O: ■■■	Digital inputs/outputs: 1, 2, 3
Analog output	½ Display	1 line	Ana: 12.345mA	Analog output
Limits	½ Display	1 line	Limits: ■■■	Limits: 1, 2, 3
Date	½ Display	1 line	2015/09/11	Date
Time	½ Display	1 line	10:37:34	Time
Hostname	½ Display	1 line	hopper1	Device name in the network
Hostname (long)	1 display	2 line	small material hopper	Device name (long)
IP address	½ Display	1 line	192.168.1.1 ---.---.---.--- ???.??.??.??	Network address No network Search DHCP server
IP address (long)	1 display	1 line	172.200.280.255	Network address (long)
Gross (2 lines high)	1 display	2 line	B +123.45 kg	Gross (2 lines high)
Net (2 lines high)	1 display	2 line	NET +123.45 kg	Net (2 lines high)
Tare (2 lines high)	1 display	2 line	T +123.45 kg	Tare (2 lines high)







3.4.3.4 LEDs

The instrument has 6 green LEDs for display of the operating or error status.

Display of the operating status

LEDs	Hardware error E:HardE	Bus connection provided	Bus connection not provided	Power on	Network active
	flashing 1 Hz				
					
					
		lit	flashing 1 Hz		
					flashing acc.
				lit	

Weight status indicator

LEDs	Standstill	Center zero	Below zero or above FSD**
	lit		
		lit	
			lit
			
			
			

** FSD (full scale deflection)

Note:

For weight error status, see Chapter [16.2](#).

3.4.4 Operating elements

3.4.4.1 Keys on the device

WARNING

Working on the device while it is switched on may have life-threatening consequences.

- ▶ Product operation must be performed by trained and qualified personnel who are aware of and able to deal with the related hazards and take suitable measures for self-protection.

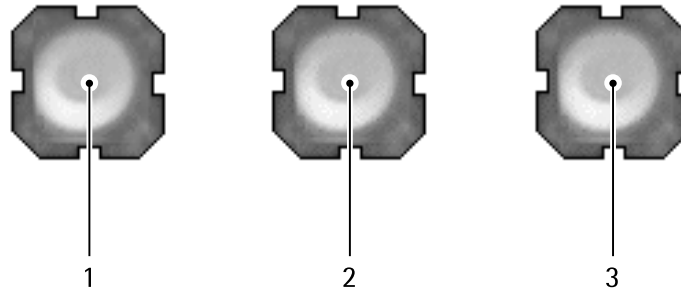

The 3 buttons are accessible only when the housing door is open. The following functions can be performed:





- Zero setting (1)
- Taring (2)
- Test measurement (3)
- Display of software version and board number by simultaneous actuation of push-buttons (1) and (3)
- Update software with the "FlashIt!32" program (see Chapter 9.4.1) by pressing the (1) and (3) keys simultaneously and pressing the (2) key three times.

Adjustment or parameter entry is







- not possible using the push-buttons.
- Only possible using a Notebook/PC via VNC (see Chapter 7.9)/Internet browser (see Chapter 7.10).

3.4.4.2 User interface







The following tables show the basic meanings of symbols on the operator interface.

Indicator keys	
	<p>Display gross weight</p>
	<p>Sets gross weight to zero, provided that</p> <ul style="list-style-type: none"> - weight value is stable; - weight is within zero setting range. <p>This function depends on the configuration.</p>
	<p>Display tare weight.</p>
	<p>Starts a printout.</p>
	<p>Taring</p> <p>The current gross weight is stored in the tare memory, provided that</p> <ul style="list-style-type: none"> - weight value is stable; - the instrument is not in error status. <p>This function depends on the configuration.</p>















Navigation/menu keys

	Scroll up in the menu.		Confirm input/selection.
	Scroll down in the menu.		<ul style="list-style-type: none"> - Backspace - Pressing the delete key deletes individual characters (within an entry).
	<ul style="list-style-type: none"> - Cursor to the left - Selection 		<ul style="list-style-type: none"> - Cancel entry/selection (after a confirmation prompt) without saving the change. - Exit parameters/menu window.
	<ul style="list-style-type: none"> - Cursor to the right - Selection 		

Function keys/softkeys

	Access the Setup menu.		Depending on the settings under  <ul style="list-style-type: none"> - [Weighingpoint]- [Calib]- [Param]- [Test mode] the following is displayed by calling the test with the key later on: <ul style="list-style-type: none"> - with "Absolute" the maximum load - with "Relative" the deviation from test value.
	Information on version number, fitted hardware, 10-fold resolution		Softkeys 1...5 Select appropriate menu function, see also Chapter 3.4.4.3 .
	No function		



Alphanumeric keypad

				Toggle key Toggle by pressing:
				<ul style="list-style-type: none"> - between alpha and numerical mode - during configuration between weight units
				
				

Alphanumeric keypad



Pressing once displays the corresponding first character, e.g., "A", at the cursor position. After pressing twice, "B" is displayed at the cursor position and after pressing three times, "C" is displayed.

Press the / cursor key to finish entering a character or wait approx. 2 seconds.

If only numeric values are required for input, letters are not enabled.

Press the  cursor key within an entry to return to the previous character.

Press the  cursor key within an entry to select the next character.

Within an input, pressing the  delete key deletes the character to the left of the cursor.

Input field

In principle

If alphanumeric characters are already present in the input field of the selected line, they will be completely overwritten after immediate entry.

If alphanumeric characters are already present in the input field of the selected line, you can press the  cursor key to select the characters to be overwritten and overwrite them.

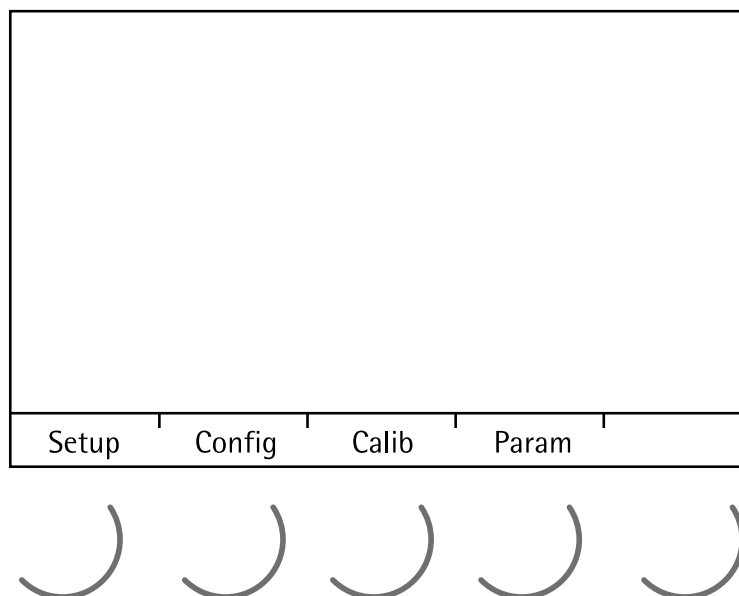

3.4.4.3 Operation using softkeys

The functions of the five softkeys  below the graphic display are indicated in the bottommost text line of the display. Softkey functions shown in gray cannot be selected at the active menu level or with the current access privileges.



In the descriptions of operating sequences which entail the use of softkeys, the softkey function to be selected is shown in square brackets; the softkey symbol is not displayed; example: [Calib].

3.4.4.4 Navigation key operation

Menu

The cursor keys, the  and  keys are used to navigate through the menus.

Parameters

Use the /  cursor keys to select the individual parameters.

Use the  key to confirm the selection.

The required values | texts are entered via the alphanumeric keys.

The  key is used to check the box.

If the list of parameters is long, a vertical bar graph on the left (black and gray) shows which part of the list is displayed.

An arrow in front of a menu item indicates that there are menu sublevels.

Possible settings and an available selection list is indicated by double arrows.

The parameter is selected using the  key.

3.4.4.5 Operation using VNC

User interface, see Chapters [3.4.2](#), [3.4.3.1](#) and [3.4.4.2](#).

3.5 Overview of connections

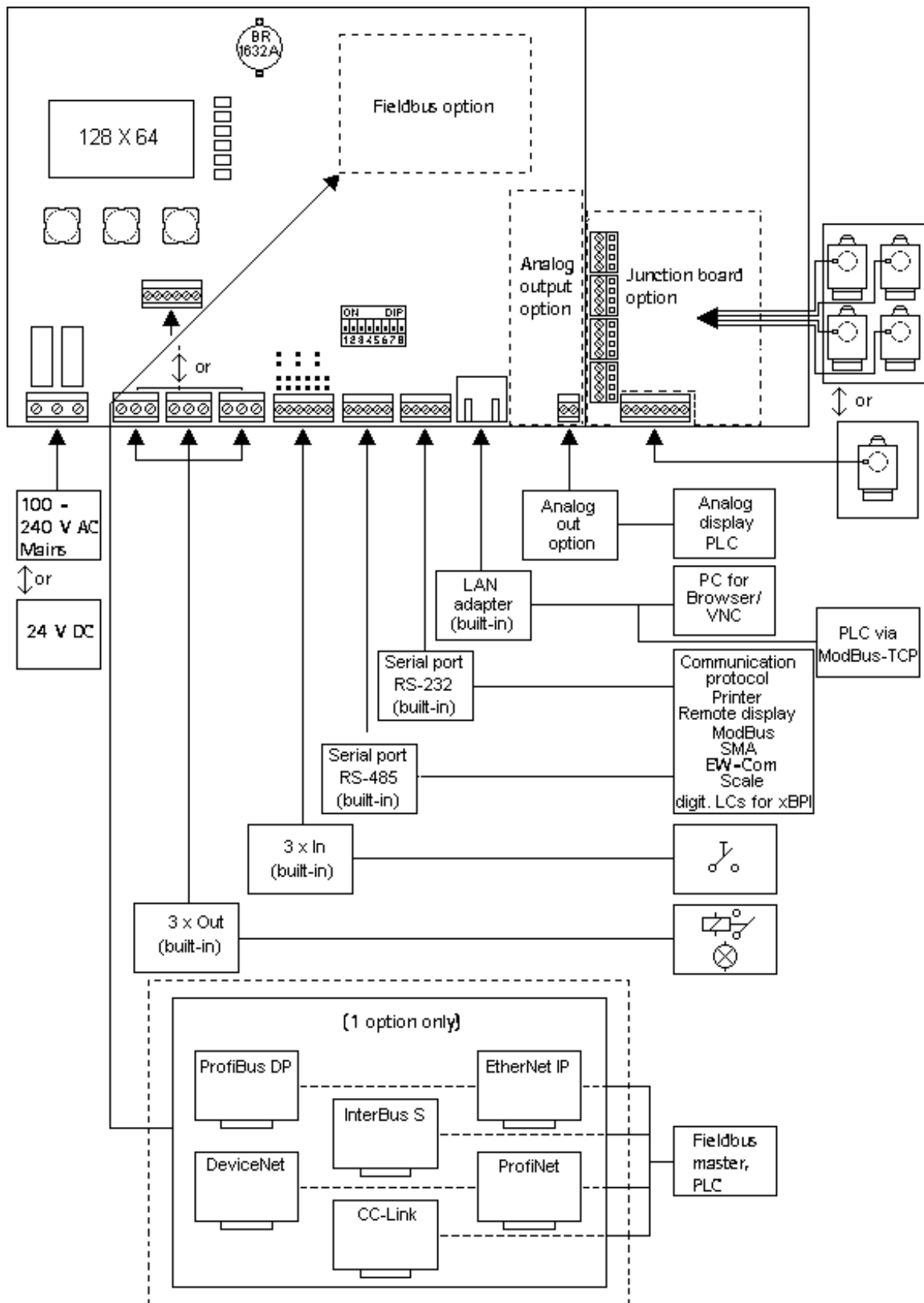

3.5.1 Plug-in cards

The main board can be fitted with 1 fieldbus card and 1 analog output board. The load cell junction board is connected to the weighing electronics board by a flat ribbon cable.

Product	Function	Position
PR 5230/06 Analog output board	Analog output 16 bits, 0/4...20 mA For more information, see Chapter 4.6.2 .	Analog output
PR 5230/22 Load cell junction board	Junction board for 2...4 load cells For more information, see Chapter 4.6.3 .	Junction board
PR 1721/41 ProfiBus DP	ProfiBus DP slave acc. to IEC 61158 with max. 12 Mbit/s For more information, see Chapter 4.6.5 .	Fieldbus
PR 1721/42 InterBus-S	InterBus-S slave with max. 500 kbit/s For more information, see Chapter 4.6.6 .	Fieldbus
PR 1721/44 DeviceNet	DeviceNet slave with max. 500 kbit/s For more information, see Chapter 4.6.7 .	Fieldbus
PR 1721/45 CC-Link	CC-Link with 156 kbit/s...10 Mbit/s For more information, see Chapter 4.6.8 .	Fieldbus
PR 1721/46 ProfiNet I/O	ProfiNet I/O with 10/100 Mbit/s For more information, see Chapter 4.6.9 .	Fieldbus
PR 1721/47 EtherNet IP	EtherNet IP with 10/100 Mbit/s For more information, see Chapter 4.6.10 .	Fieldbus

3.6 Device variants

3.6.1 Combinations for options

Description	Accessories	Ident.	Description	Chapter
Electronics:				
Analog/digital converter	Standard	W1	Weighing electronics board	4.4.3
	with explosive environment certification	WE1	Weighing electronics board with intrinsically safe load cell supply for operation of load cells/platforms in Zones 1 and 21	Option WE1 additional information
Power supply:				
Power supply	Standard	L0	230 V AC version	2.4.3.1
		L8	24 V DC version	2.4.3.2
Internal inputs:				

Description	Accessories	Ident.	Description	Chapter
Digital inputs	Standard	DE1	3 passive (external supply) opto-decoupled inputs	4.4.7
		DE2	3 active (internal 12 V supply) opto-decoupled inputs	4.4.7
Internal outputs:				
Digital outputs	Standard	DA1	3 passive relay outputs (external supply)	4.4.8.1
		DA2	3 passive (external supply) opto-decoupled outputs	4.4.8.2
Interface cards:				
Interface slot 1	Standard	None		
	PR 5230/06	C11	1 analog output (0/4...20 mA)	4.6.2
Interface slot 2	Standard	None		
	PR 1721/41	C21	Profibus-DP	4.6.5
	PR 1721/42	C22	InterBus-S	4.6.6
	PR 1721/44	C24	DeviceNet	4.6.7
	PR 1721/45	C25	CC-Link	4.6.8
	PR 1721/46	C26	ProfiNet I/O	4.6.9
	PR 1721/47	C27	EtherNet IP	4.6.10
Interface slot 3	Standard	None		
	PR 5230/22	C31	Load cell junction board	4.6.3
Cable connections:				
For the "Built-in" Ethernet interface only: Connection cable for network	Standard	None		
	PR 5230/30	M39	Ethernet socket, RJ-45 connector, IP67 Note: cannot be combined with Y2!	4.6.11
	PR 5230/31	M40	Ethernet cable, 7 m long, metric cable gland, RJ-45 connector, industry version	4.6.12

The type identifier (e.g., PR 5230-WE1-C21-DA2) for the device variant (basic unit + option) is located on a label inside the door of the device.

4 Device installation

4.1 General notes

Before starting work, please read Chapter 2 and follow all instructions.

WARNING

Warning of hazardous area and/or personal injury

- ▶ All cable connections must be protected from damage.

Note:

- Measurement cables should be kept away from power equipment.
- Signal cables and measurement cables should be installed separately from electric power lines.
- It is recommended that measurement cables are laid in separate cable conduits.
- Power cables should be crossed at right angles.

Further procedures:

- Check the consignment: make sure that all components are present.
- Safety check: inspect all components for damage.
- Make sure that the on-site installation is correct and complete including cables, e.g. power cable fuse protection, load cells, junction box, data cables, console/cabinet, etc.
- If necessary, install the plug-in cards (device must be disconnected from all voltage sources).
- Follow all device installation instructions related to application, safety, ventilation, sealing and environmental influences.
- Connect the cable from the junction box or platform/load cell.
- If applicable: connect other data cables, network cables, etc.
- Connect to supply voltage.
- Check the installation.

4.2 Mechanical preparation

4.2.1 General information

Have all required parts, technical documents and tools at hand for mounting.

- Secure the cable at the place of installation; e.g., using cable ties.
- Remove the insulation from the cable ends, keep the strands short and fit them with ferrules.

4.2.2 Cable gland

The cables have to be fed into the device via glands to ensure leak-tightness. The following cable diameters are suitable: 9...13 mm for gland M20×1.5 and 5...9 mm for cable gland M16×1.5.

The cable wires are connected to the terminals inside the device.

The connections are made via plug-in terminals.

The conductors taken to the terminals shall be as short as possible. The wires of each cable must be tied together with a cable strap shortly before the terminal.

NOTICE

For protection against dust and moisture during transport and installation, the cable glands are fitted with a polyethylene cover.

For full IP protection, operation with the dust protection cover fitted is not permitted.

- ▶ Remove the dust protection cover.
- ▶ If a cable gland is not used, it must be sealed with a supplied locking pin.

NOTICE

Property damage is possible.

- ▶ Regularly check the fitted cable gland for tightness and re-tighten it, if necessary.

4.2.3 Cabling

In principle, the cables can be taken through all cable glands corresponding to the cable diameters. The following figure shows a proposed topology:

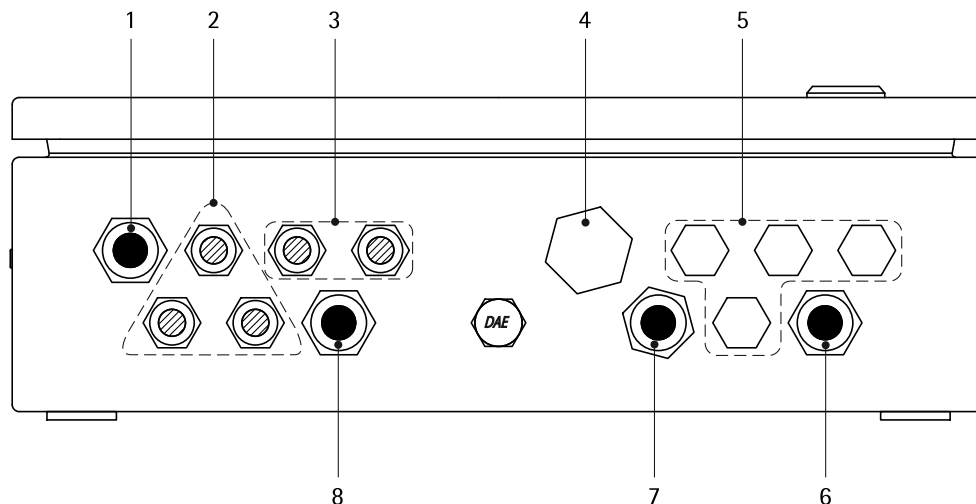

No.	Description
1	Power supply: 230 V AC or 24 V DC
2	Digital outputs: Relay/optocoupler
3	Serial interfaces
4	Ethernet socket (option/accessory)

No.	Description
5	1...4 load cells
6	1 load cell or junction box or fieldbus cards
7	Analog output or fieldbus cards
8	Digital inputs: internal/external

4.2.4 Installation of a cable

NOTICE

Material damage is possible.

- ▶ Perform the connection of the cable screen for the fieldbus cards according to the relevant chapter.

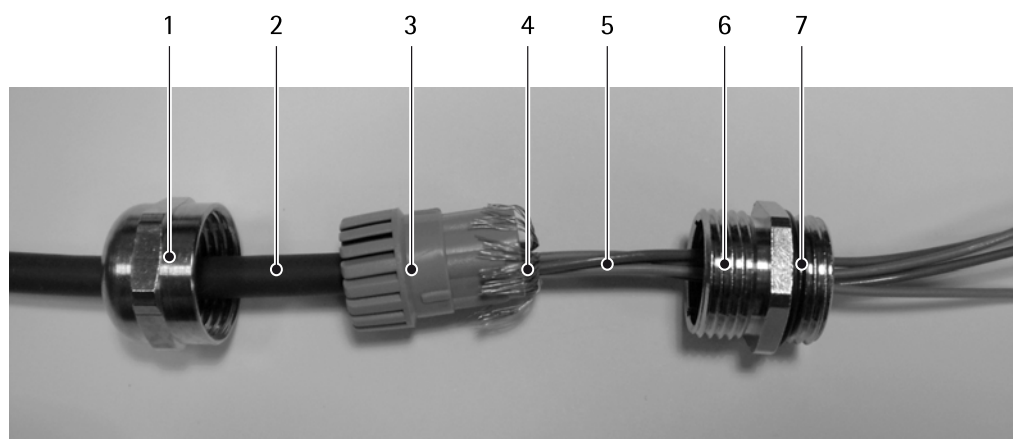

NOTICE

Material damage is possible.

Do not guide the screen (4) into the device!

- ▶ The cable shield (4) must be connected in the metal sleeve (6) of the cable gland.
- ▶ Before, during and after installation, make sure that the sealing ring is seated correctly.

1. Unscrew the sleeve screw cap (1).
2. Slide the cap (1) and plastic cone (3) onto the cable (2).
3. Guide the cable (5) through the gland (6).
4. Fold the cable shield (4) over the lower part of the terminal insert (3) (approx. 10 mm).
5. Connect the cable conductors.
6. Tighten the sleeve screw cap (1).
7. Secure the gland (6) including the o-ring (7) using the counter nut (in the housing).

NOTICE**Material damage is possible.**

- ▶ Regularly check the cable gland for tightness and re-tighten it, if necessary.

4.3 EMC-compliant installation**4.3.1 Connecting the screens**

The screens must be connected as described in Chapter [4.2.4](#).

4.3.2 Connecting the equipotential bonding conductor

In potentially explosive atmospheres an equipotential bonding conductor must be connected; see option WE1 additional information.

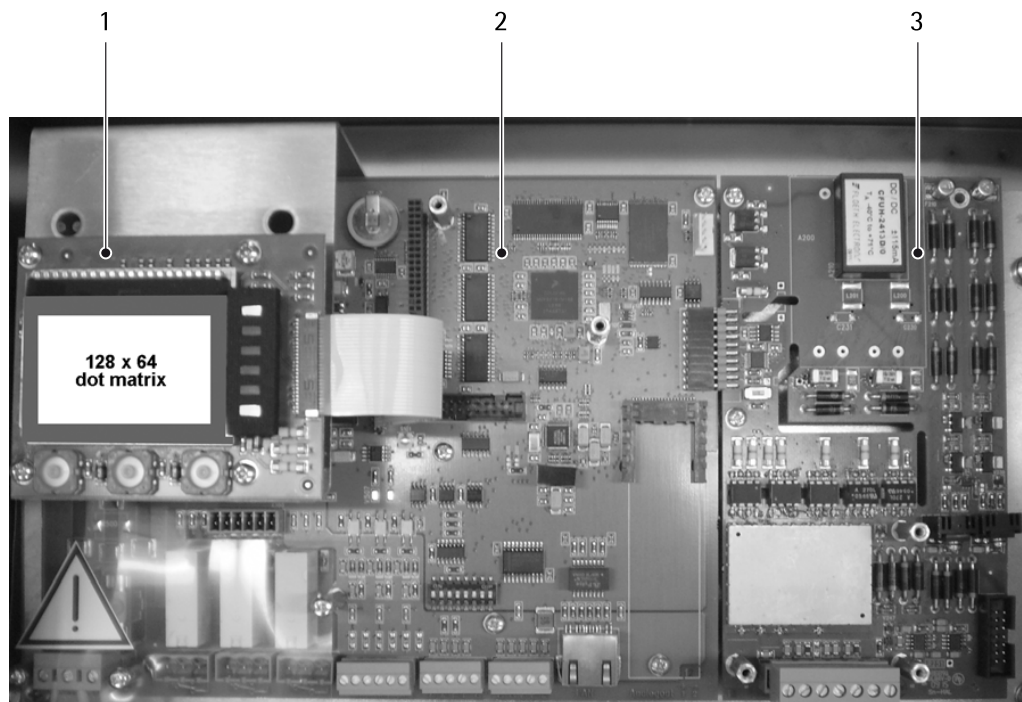
4.4 Hardware construction

The overall electronics is installed on the following units:

- Mainboard (2)
- Display board (1)
- Weighing electronics board (3)

4.4.1 Main board

The main board provides the slots for the

- Analog output board (4), option/accessories
- Fieldbus card (3), option/accessories

The lithium battery (2) is always activated and powers the calendar/clock module.

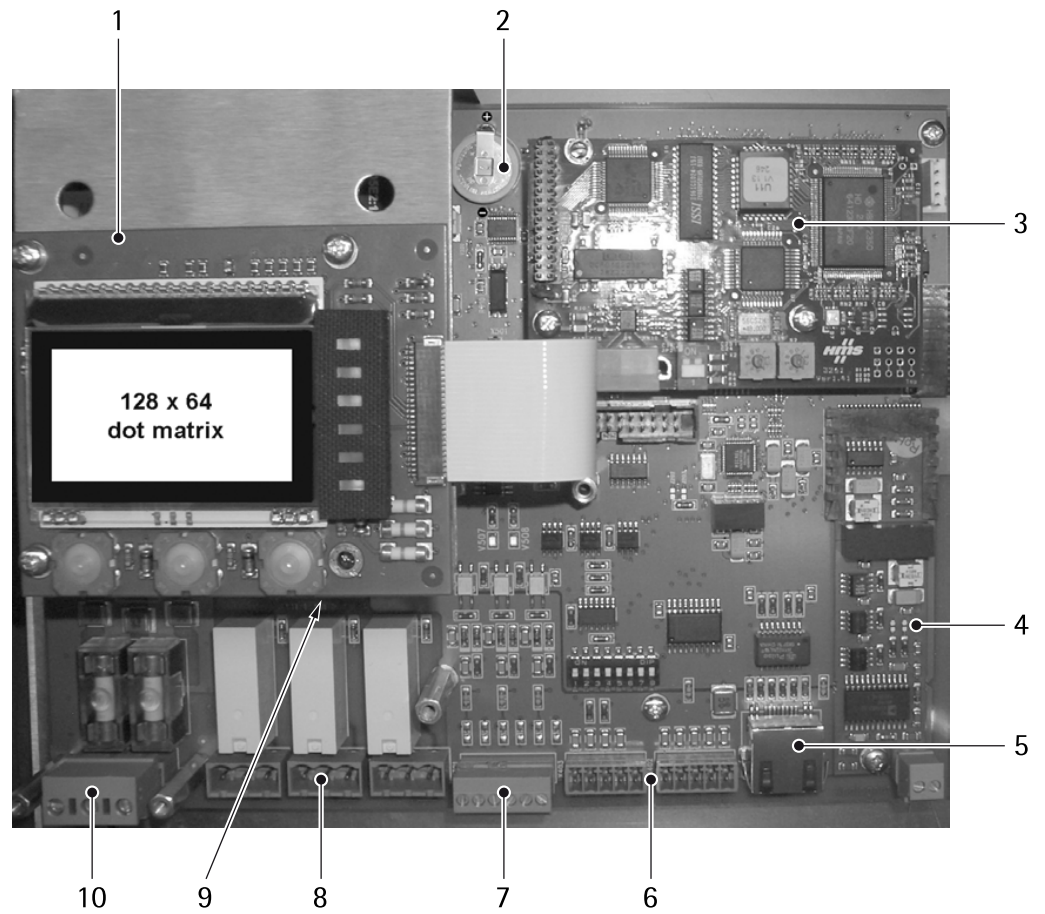

No.	Description
1	Display board
2	Lithium battery
3	Fieldbus card
4	Analog output board
5	Ethernet port
6	Serial interfaces
7	Digital inputs
8	Relay outputs
9	Opto-decoupled outputs (option)
10	Power supply

4.4.2 Display board

The display board is connected to the main board by a ribbon cable.

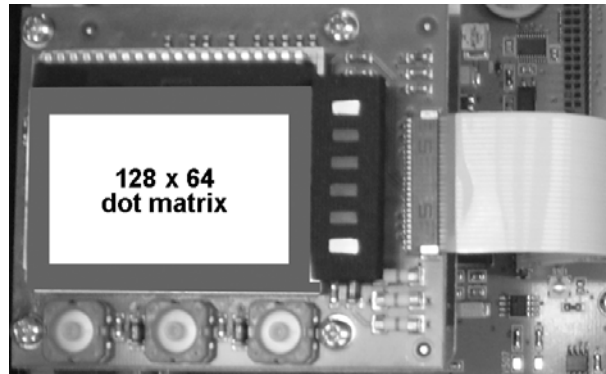

4.4.3 Weighing electronics board

The weighing electronics board is plugged into the main board.

Two weighing electronics board versions are available:

- Standard (W1)
- With intrinsically safe load cell supply for operation of load cells/platforms in zones 1 and 21 (WE1); see Option WE1 additional information.

The load cell junction board (see Chapter [4.6.3](#)) is connected to the weighing electronics board using a ribbon cable for direct connection of up to four load cells.

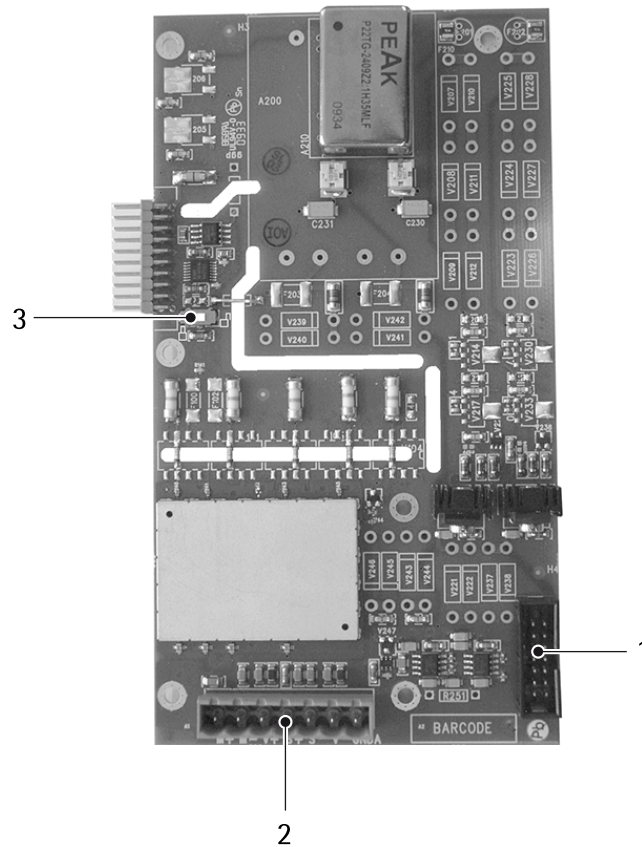

No.	Description
1	Load cell junction board connector
2	Load cell/junction box/scale connector
3	CAL switch

Note:

The weighing electronics board (W1) is also available as a spare part; see Chapter [18.1.1](#).

Technical data

Description	Data
Connection	7-pin plug (male), screen connection on housing and to GNDA
Number of channels	1× 6-wire or 4-wire
Load cell type	SG cells, 6- or 4-wire connection possible
Load cell supply	$U_{DC} = 12\text{ V}$, symmetrical to zero ($U_{DC} = \pm 6\text{ V}$, $I_{max} = 160\text{ mA}$)
Capacity (number of load cells)	$\geq 75\ \Omega$, corresponding to 8 load cells with $650\ \Omega$ or 4 load cells with $350\ \Omega$
Sense input	$U_{DC} = \pm 6\text{ V}$, with monitoring

Description	Data
Sense voltage monitoring	Sense voltage below 8 V, switchable to <8 V
Measurement input	$U_{DC} = 0...36 \text{ mV}$, symmetrical to 0
Dead load suppression	$U_{DC} = \text{max. } 36 \text{ mV}$ (dead load + range)
Accuracy*	0.8 $\mu\text{V/d}$ corr. to 4.8 mV for 6,000 d 0.8 $\mu\text{V/d}$ corr. to 8.0 mV for 10,000 d
Min. measuring signal*	6,000 d: $\geq 0.40 \text{ mV/V}$ 10,000 d: $\geq 0.66 \text{ mV/V}$
Max. resolution	7.5 million internal counts at 3 mV/V
Linearity*	<0.003 %
Zero point stability error (T _{ko})*	<0.05 $\mu\text{V/K RTI}$; 0.004%/10 K at 1 mV/V
SPAN stability error (T _{kspan})*	< $\pm 2.5 \text{ ppm/K}$
Cable type	6-wire with screen for entire cable and screen for measurement cables, e.g. PR 6135/..
Cable length	max. 300 m

* with a measurement time of 160 ms

4.4.4 Network port

The device has an internal Ethernet port.

NOTICE

Damaged data will bring a stop to IT operations.

Protect the IT network to prevent unauthorized access.

► The current IT security guidelines must be followed so as to minimize the risks.

4.4.4.1 Ethernet port

The Ethernet port contains a powerful TCP/IP interface connection with transfer rates of 10 or 100 Mbit/s.

Function tests can be performed via the LED to the right of the display (see Chapter [3.4.3.4](#)) or also via the LEDs (green and yellow) in the RJ-45 socket when the housing is open.

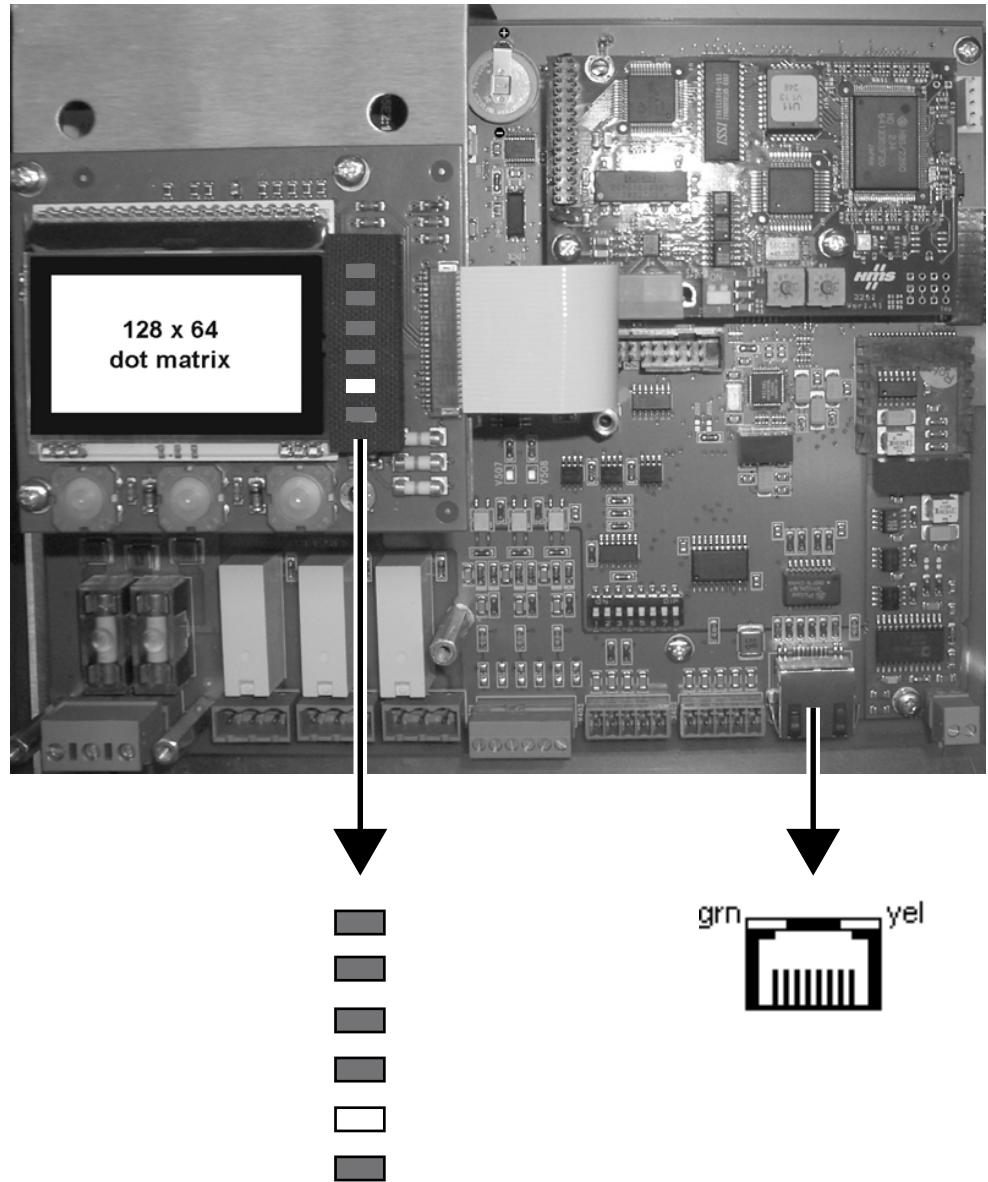

Technical data

Description	Data
Connection 	RJ-45 socket inside the device Green (grn): flashing on data traffic (activity) Yellow (yel): lights up when there is an existing connection (link)
Transfer rate	10 Mbit/s, 100 Mbit/s, full/half duplex, auto-detection
Connection mode	Point to point
Potential isolation	Yes
Cable type	CAT 5 patch cable, twisted pair, screened
Cable impedance	150 Ω
Cable length	Max. 115 m

4.4.4.2 Notebook/PC connection

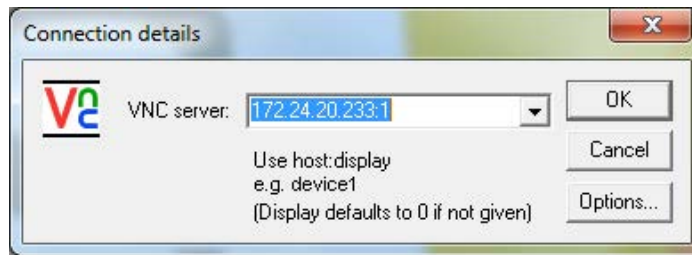

Remote operation of the device from a notebook/PC is possible (install VNC software version 3.3.7* on the notebook/PC).

For the network address, see Chapter 7.7.

* Minebea Intec guarantees the functionality only if this version is used.

4.4.5 RS-232 interface

The device is equipped with an integrated RS-232 interface.

This interface is configurable, and can be used, for example, for data transmission to a remote display or printer.

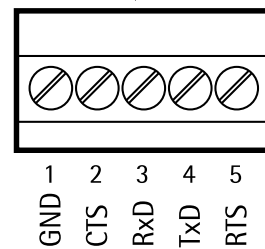
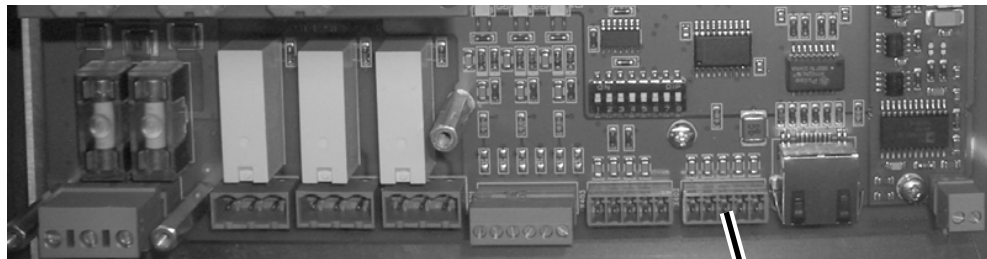

Technical data

Description	Data
Connection	Terminal, 5-pin
Number of channels	1
Type	RS-232, full duplex
Transmission rate [bit/s]	300 to 115K2 bit/s
Data bits	7/8
Input signal level	Logic 1 (high) -3 to -15 V Logic 0 (low) +3 to +15 V

Description	Data
Output signal level	Logic 1 (high) -5 to -15 V Logic 0 (low) +5 to +15 V
Number of signals	Input: RxD, CTS Output: TxD, RTS
Potential isolation	None
Cable type	Twisted pair, screened (e.g., LifYCY 3×2×0.20), 1 pair of wires for ground (GND)
Cable gauge	1.5 mm ²
Cable length	Max.15 m

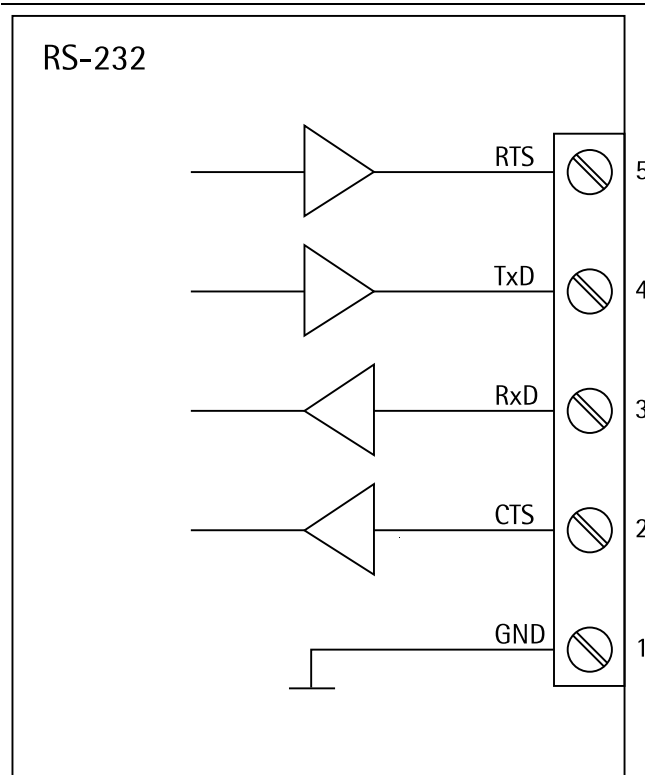
Block diagram RS-232**Note:**

After 30 seconds without data exchange, RTS and TxD are switched off.

4.4.5.1 Connecting a YDP14IS ticket printer

The YDP14IS-OCEUV ticket printer can be connected via the internal RS-232 interface.

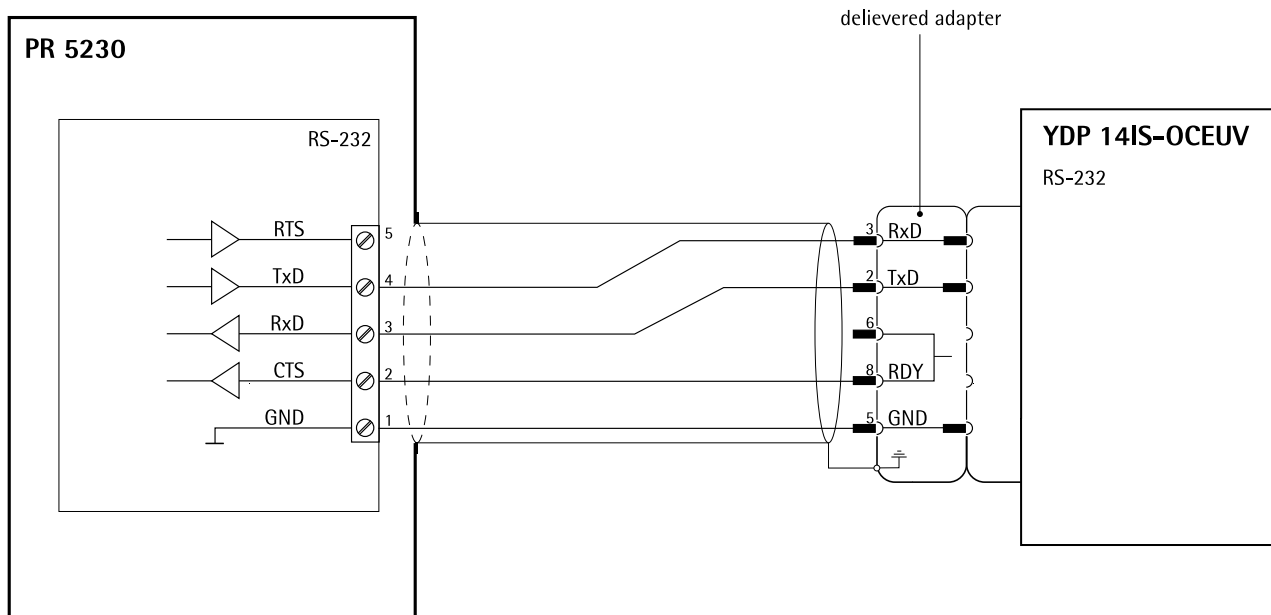

Configuration PR 5230

-  - [Serial ports parameters] - [Printer] - [Built-in RS-232] - [Param]:
- [Protocol] to "RTS/CTS"
 - [Baudrate] to "9600"
 - [Bits] to "8"
 - [Parity] to "none"
 - [Stop bits] to "1"
 - [Output mode] to "Raw"

Printer configuration

The printer must be set to "Line Mode" (the factory setting is Page Mode). Press the "FEED" key to switch from one to the other. The procedure can be found in the printer operating instructions.

4.4.5.2 Connecting an IS platform

One IS platform scale with xBPI or SBI protocol can be connected via the internal RS-232 interface.

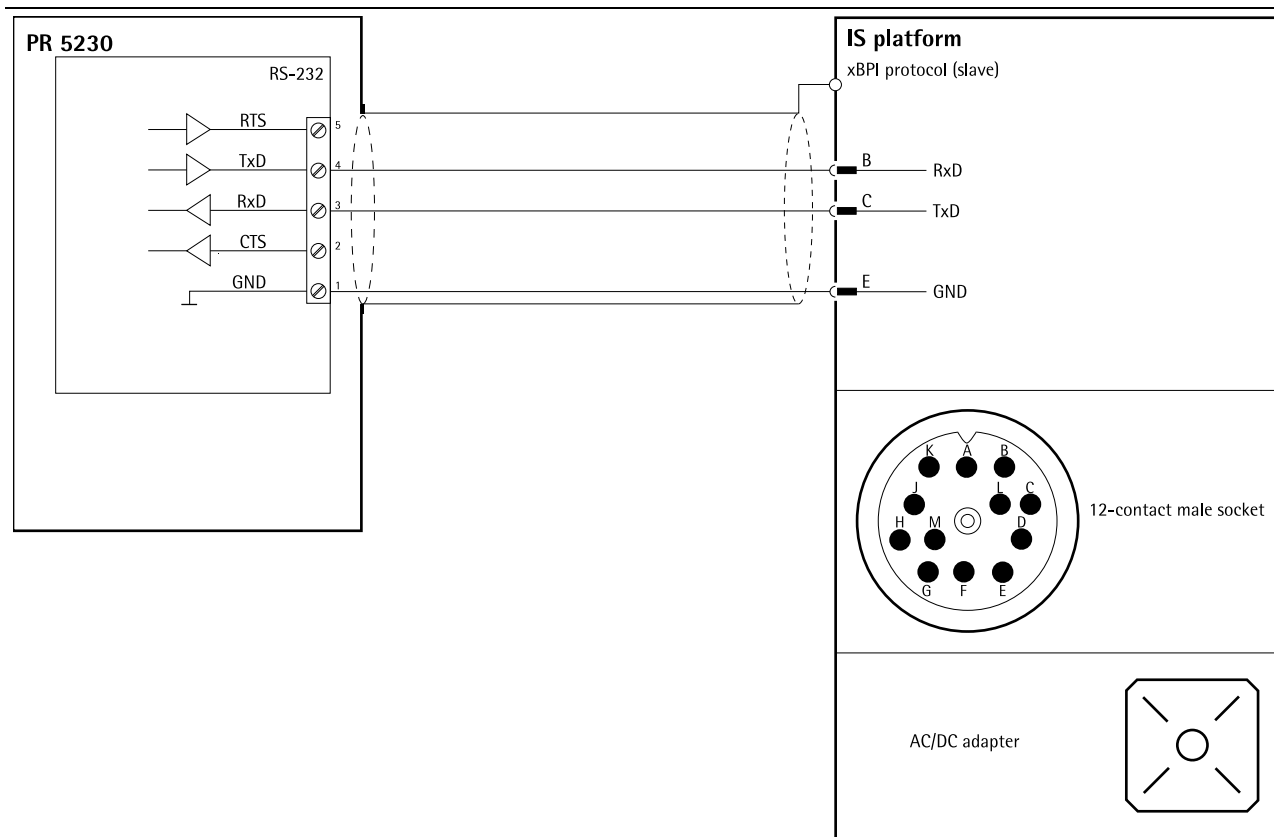

Configuration PR 5230

 - [Serial ports parameters] - [xBPI port] - [Built-in RS-232]

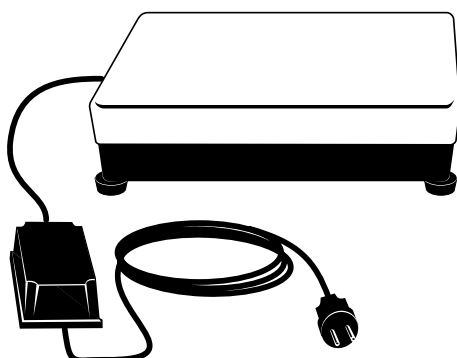

Note:

For further information, see the platform scale operating instructions.

4.4.6 RS-485 interface

Using RS-485 is compulsory with a multi-point connection (Tristate status).

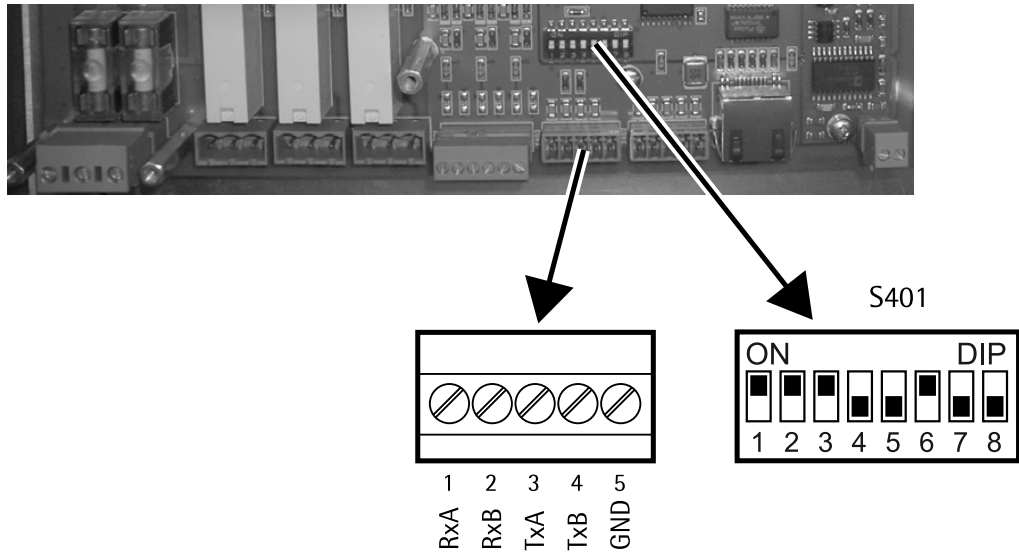

Technical data

Description	Data
Connection	Terminal, 5-pin
Number of channels	1
Type	RS-485, full duplex
Transmission rate [bit/s]	300, 600, 1200, 2400, 4800, <9600>, 19200
Bits/Stopbit	<8/1> or 7/1
Parity	even, <uneven>, none
Signals	TxA, RxA, TxB, RxB
Potential isolation	yes
Cable type	Twisted pair, screened (e.g., LifYCY 3x2x0.20), 1 pair of wires for ground (GND)
Cable gauge	1.5 mm ²
Cable length	max. 1000 m

<...> = preset values (factory settings)

S401 switch

Block diagram RS-485

The S401 switch is located on the mainboard in the device.
Factory settings:

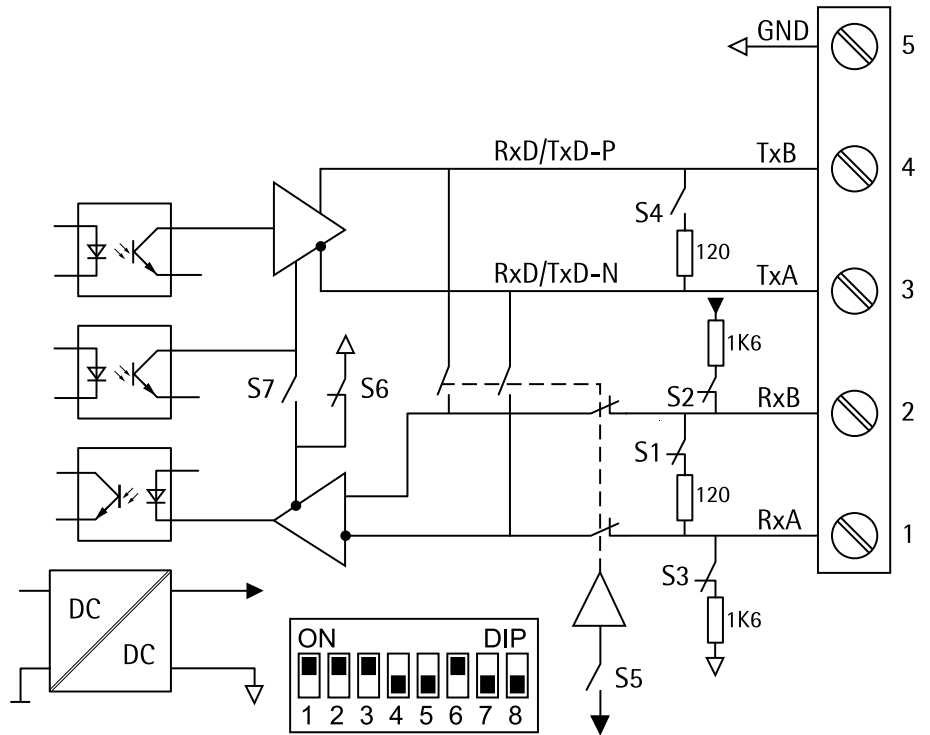
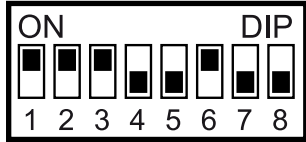

S	Function	Settings for RS-485	
1	Rx bus termination	OFF: not connected	ON: (RxA 120 Ω RxB)
2	Rx pull-up resistor	OFF: not connected	ON: (RxB 1K6 Ω +V)
3	Rx pull-down resistor	OFF: not connected	ON: (RxB 1K6 Ω -V)
4	Tx/Rx bus termination	OFF: not connected	ON: (TxA 120 Ω TxB)
5	Changeover 2 to 4 wires	OFF: 4-wire	ON: 2-wire
6	Rx enable (released)	OFF: Rx disabled (locked); if Tx enabled (released): S7 must be "ON".	ON: Rx always enabled (released): For 4-wire, S7 must be "OFF".
7	Tx enable (released)/Rx disable (lock) (2-wire)	OFF: S6 must be "ON".	ON: S6 must be "OFF".
8	n.c.	No function	

4.4.6.1 Connecting to a PC or an RS-485/RS-232 converter

Point-to-point connection for the following protocols (4-wire):

- SMA
- EW-Com
- ModBus

Example:

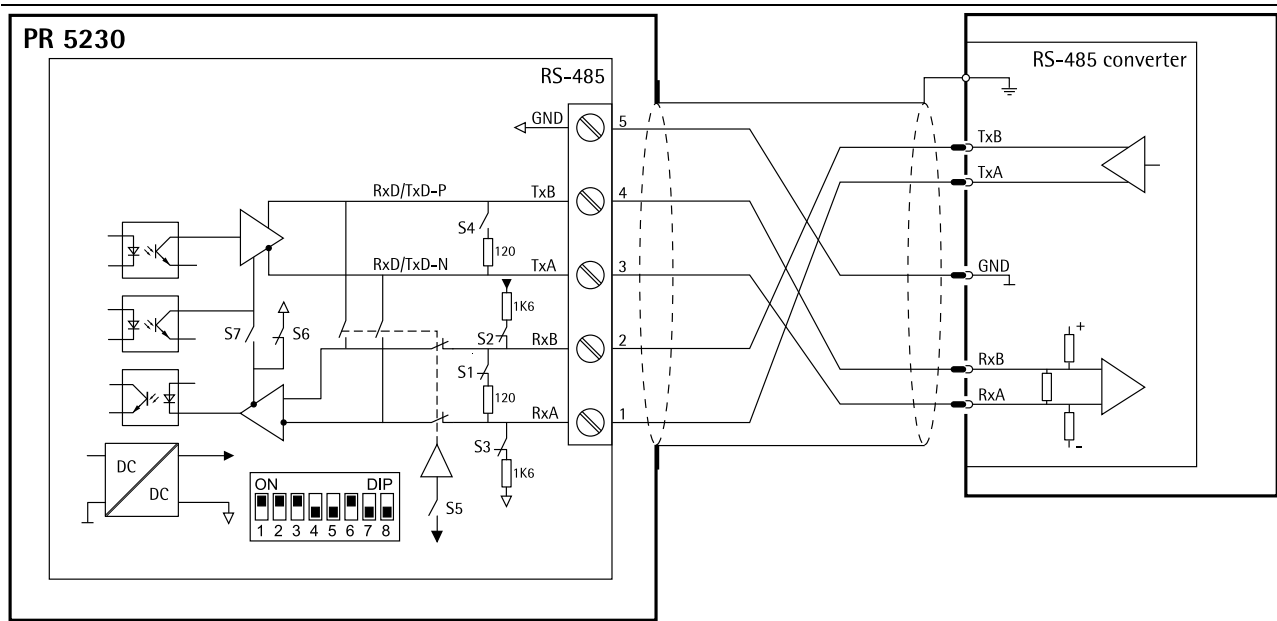

Switch settings

ON: S1, S2, S3, S6
 OFF: S4, S5, S7, S8

Configuration

- [Serial ports parameters] - [...] - [Built-in RS-485]

4.4.6.2 Connecting multiple PR 5230 units to a PC or to an RS-485/RS-232 Converter

Point-to-point connection for the EW-Com protocol (4-wire).

Example:

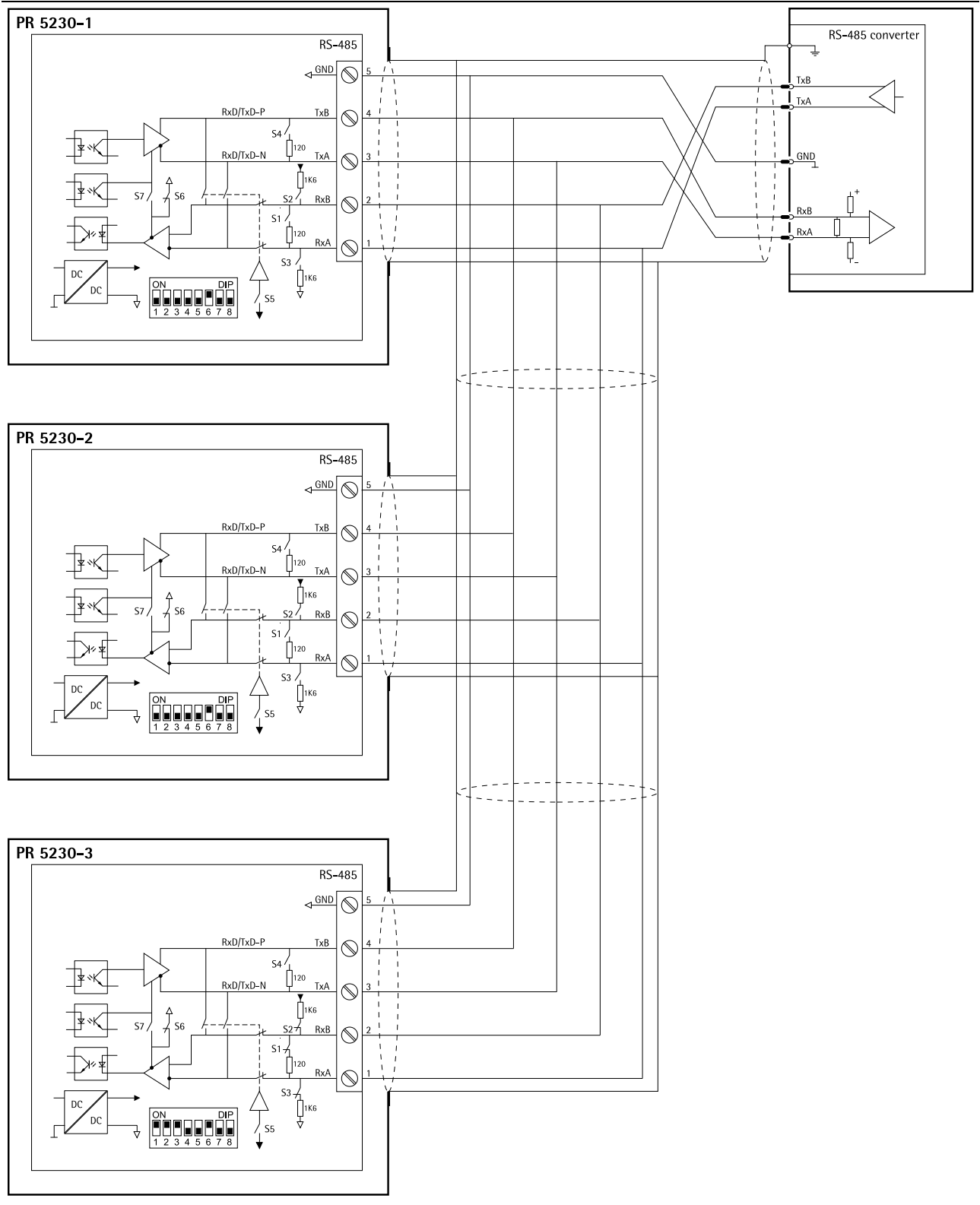

Switch setting PR 5230-1	Switch setting PR 5230-2	Switch setting PR 5230-3	Configuration
ON: S6 OFF: S1, S2, S3, S4, S5, S7, S8	ON: S6 OFF: S1, S2, S3, S4, S5, S7, S8	ON: S1, S2, S3, S6 OFF: S4, S5, S7, S8	 - [Serial ports parameters] - [EW-Com] - [Built-in RS-485]

4.4.6.3 Connecting to a PLC

Point-to-point connection for the following protocols (2-wire):

- ModBus
- xBPI

Example:

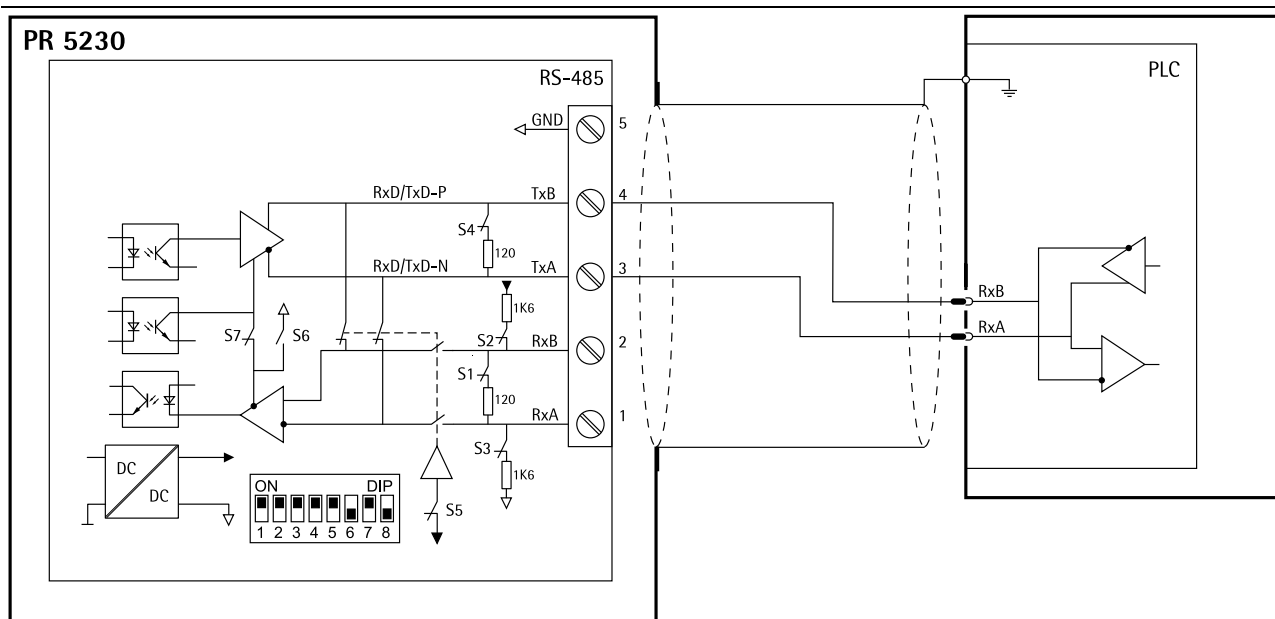



Switch settings	Configuration
ON: S1, S2, S3, S4, S5, S7 OFF: S6, S8	 - [Serial ports parameters] - [...] - [Built-in RS-485]

4.4.6.4 Connecting several PR 5230 to PLC

Point-to-point connection for following protocols (2-wire):

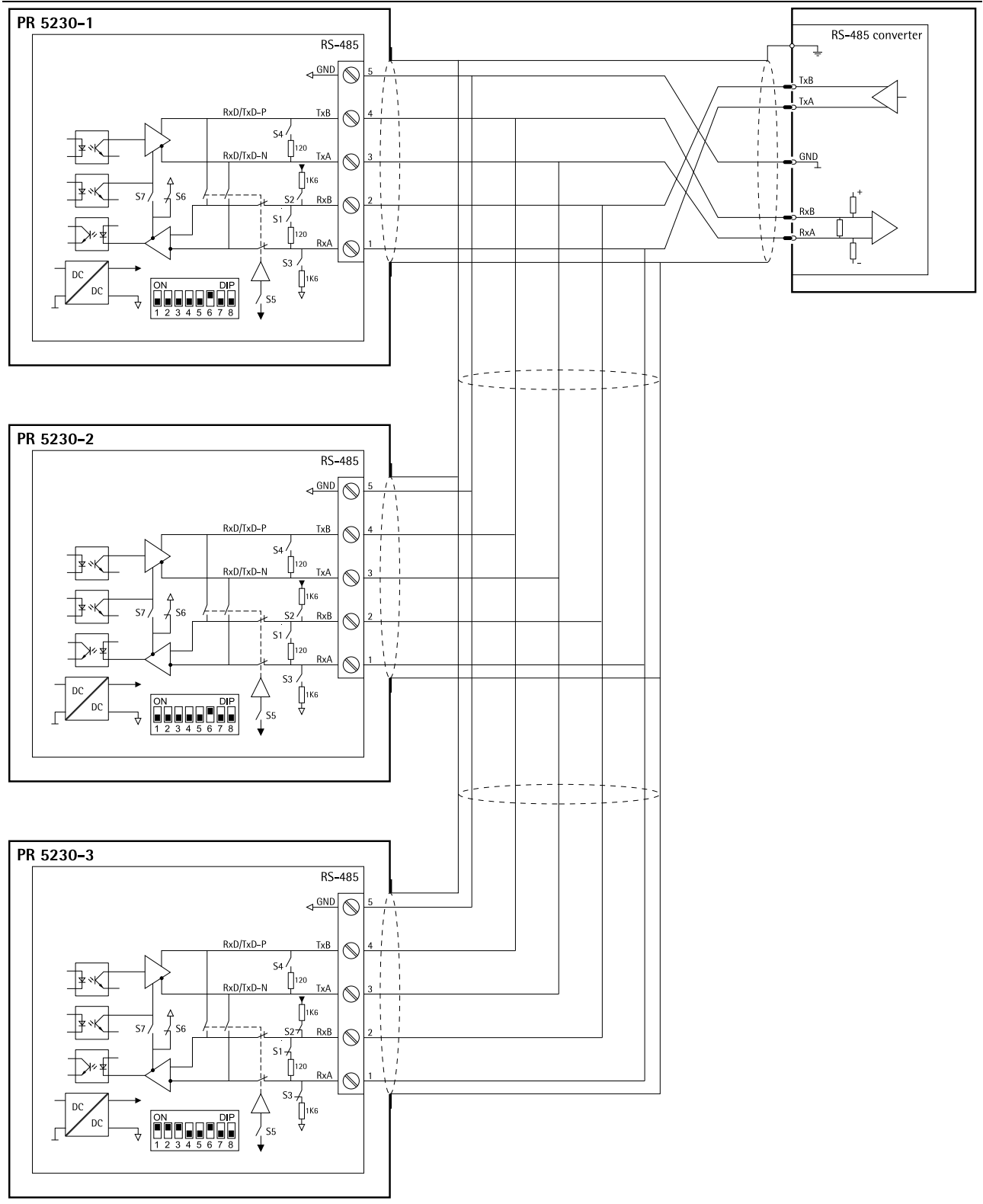
- ModBus
- xBPI



Switch setting PR 5230-1	Switch setting PR 5230-2	Switch setting PR 5230-3	Configuration
ON: S1, S2, S3, S5, S7 OFF: S4, S6, S8	ON: S1, S2, S3, S5, S7 OFF: S4, S6, S8	ON: S1, S2, S3, S4, S5, S7 OFF: S6, S8	 - [Serial ports parameter] - [...] - [Built-in RS485]

4.4.6.5 Connecting an IS platform

One IS platform scale with xBPI or SBI protocol can be connected via the RS-485 interface (2-wire).

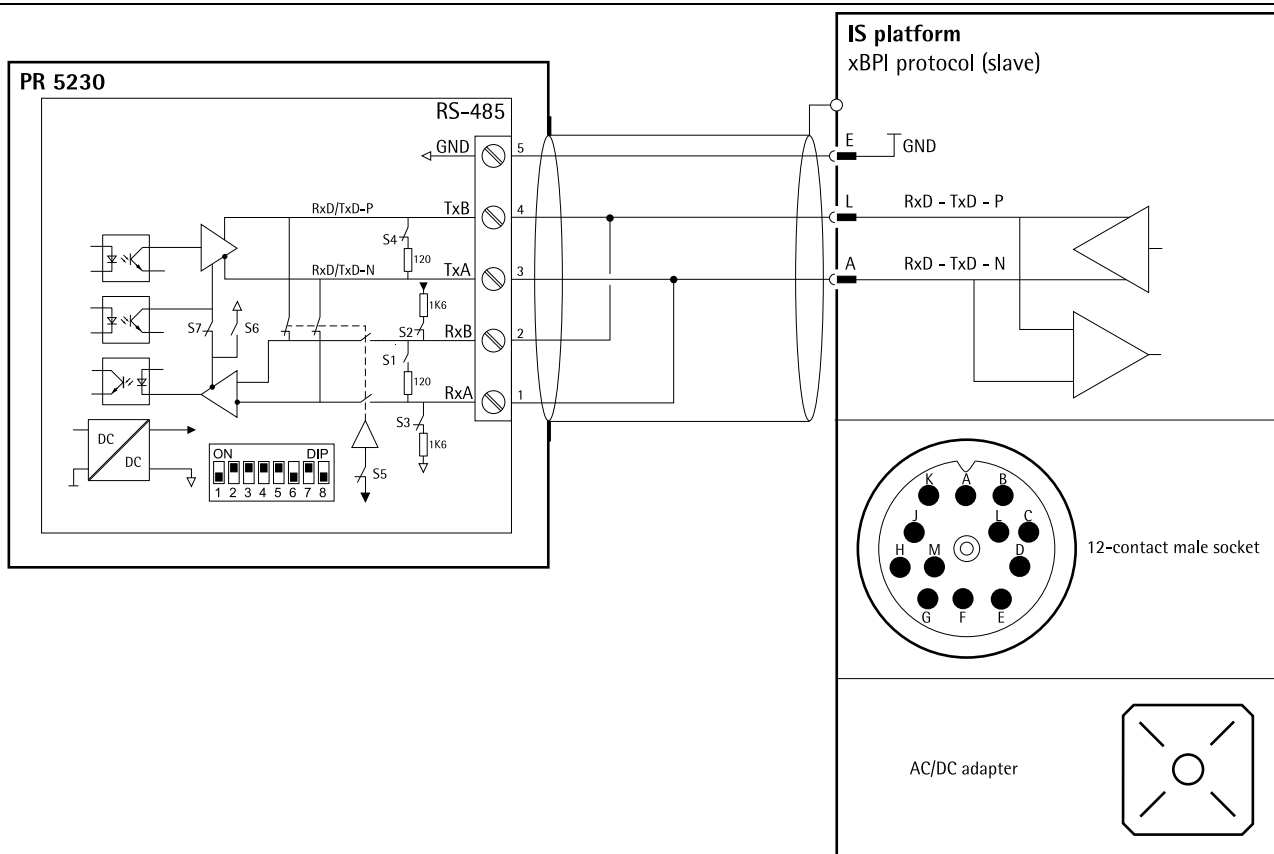

Switch settings PR 5230

ON: S1, S2, S3, S4, S5, S7
OFF: S1, S6, S8

Configuration PR 5230

 - [Serial ports parameters]- [xBPI port]- [Built-in RS-485]

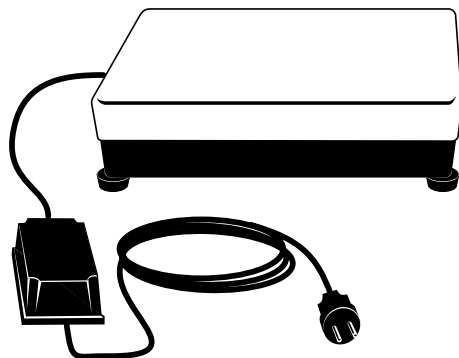
**Note:**

For further information, see the platform scale operating instructions.

4.4.6.6 Connecting digital load cells from type Pendeo®

The device can be ported to Pendeo® type digital load cells via the xBPI port and the RS-485 interface (2-wire).

Connections

Color code	Color	Terminal designation	Description
rd	red	+	+ Supply voltage
bu	blue	-	- Supply voltage
gr	green	B	B Signal
gy	gray	A	A Signal

The following example shows the connection to the PR 6024/68S junction box using 8 digital load cells, type Pendeo®.

Connection example

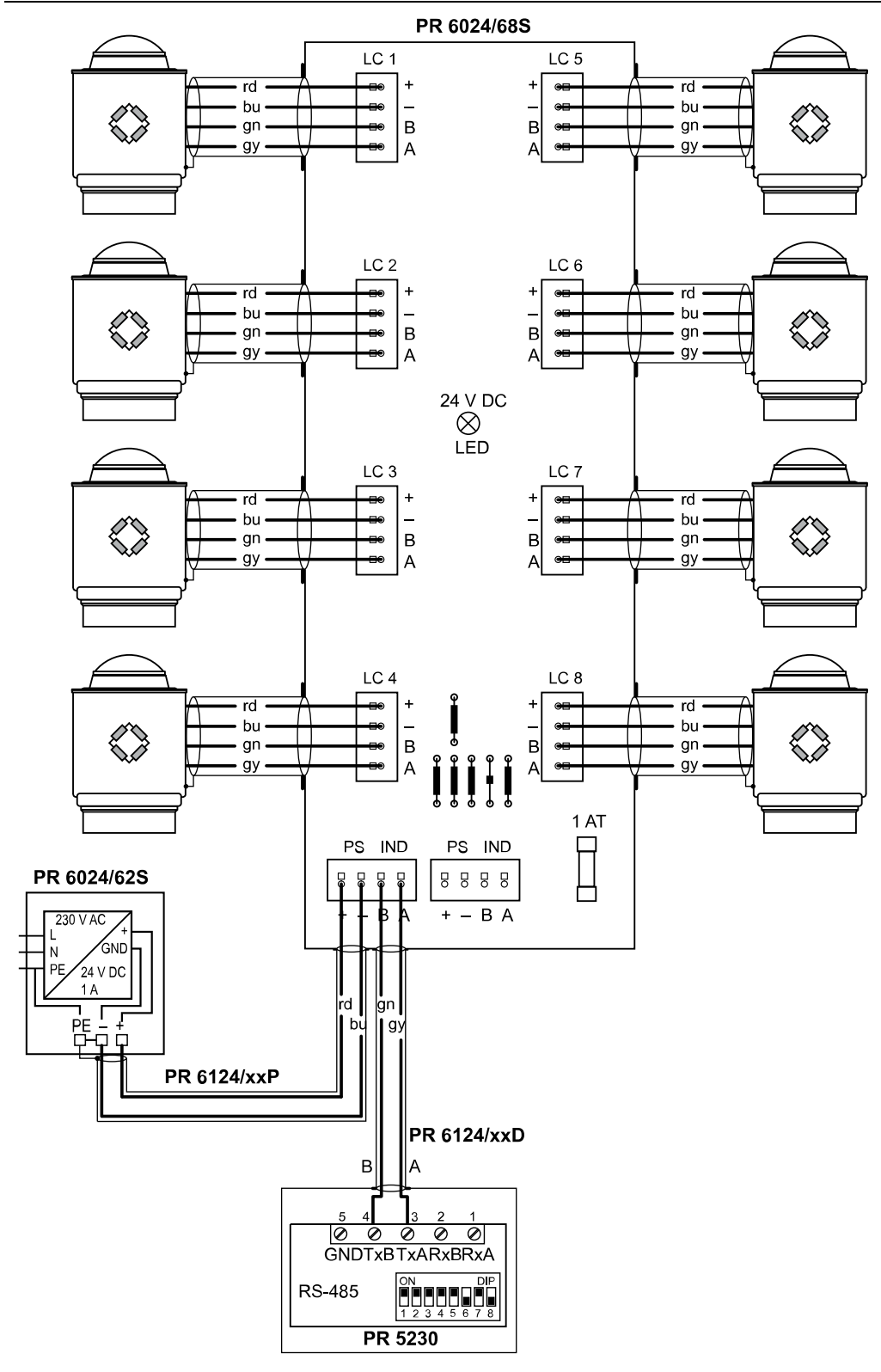

PR 5230 switch settings	PR 5230 configuration
ON: S1, S2, S3, S4, S5, S7 OFF: S6, S8	 - [Serial ports parameter] - [xBPI-Port] - [Built-in RS-485]

Note:

For further information, see the installation manuals relating to the load cells and junction boxes.

4.4.7 Digital inputs

The main board is equipped with 3 digital inputs for the process control. They are electrically isolated by optocouplers and each 2-pin potential-free.

The interface can be configured by software.

Depending on the order, the hardware is factory-set to "passive" (order code "DE1") or "active" (order code "DE2").

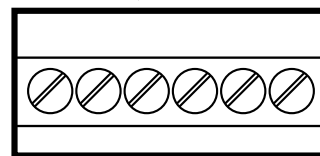
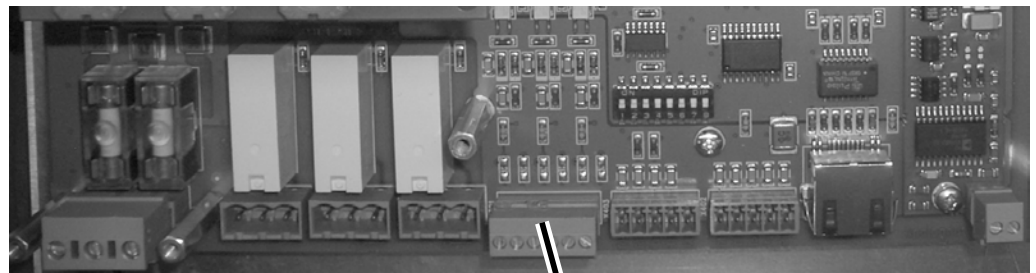

+ - + - + -
CH1 CH2 CH3

Technical data

Description	Data
Connection	Terminal, 6-pin
Number of inputs	3 (CH1, CH2, CH3)
Input voltage	Logic 0: $U_{DC} = 0$ to 5 V or open Logic 1: $U_{DC} = 10$ to 28 V Active: Internal $U_{DC} = 12$ V power supply. Passive: External power supply required.

Description	Data
Input current	≤11 mA @U _{DC} = 24 V ≤5 mA @ U _{DC} = 12 V Protection against incorrect polarity.
Potential isolation	Active: Jointly supplied via potential-free voltage. Passive: Via optocoupler
Cables	Screened Connect cable screen (wire gauge max. 1.5 mm ²) to the sleeve of the cable gland.
Cable length	Max. 50 m

Example:

Standard: Contact input "passive" (order code "DE1")

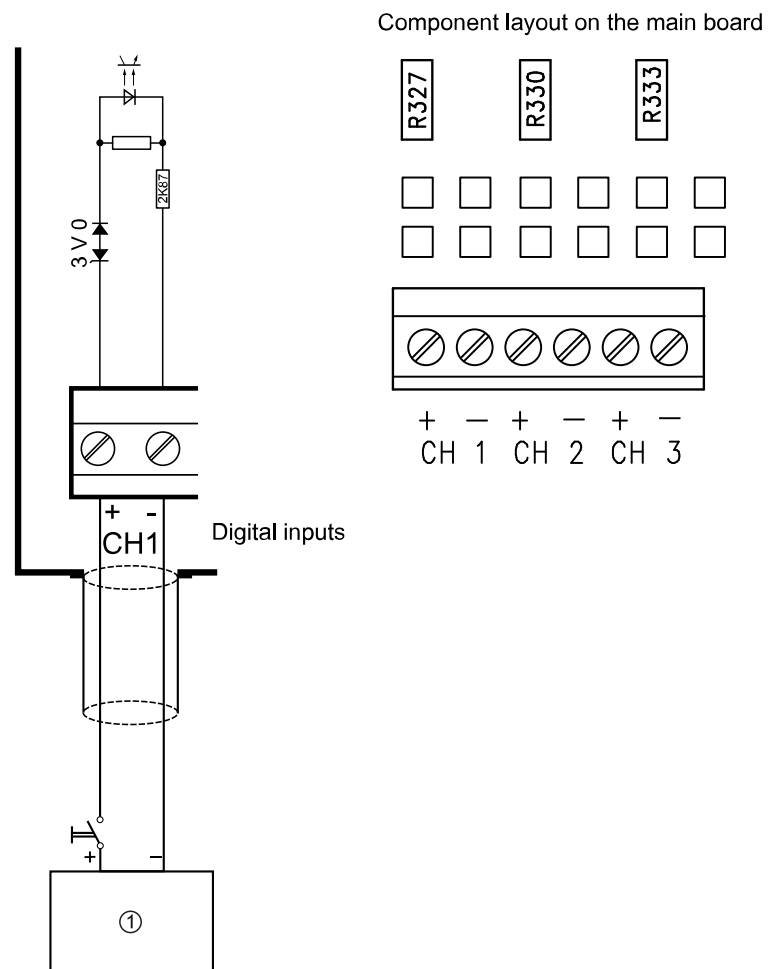

① Supply unit $U_{DC} = 24\text{ V } 0.5\text{ A}$

Note:

Resistors R327, R330, and R333 are $0\ \Omega$ links.

Example:

Option: Contact input "active" (order code "DE2")

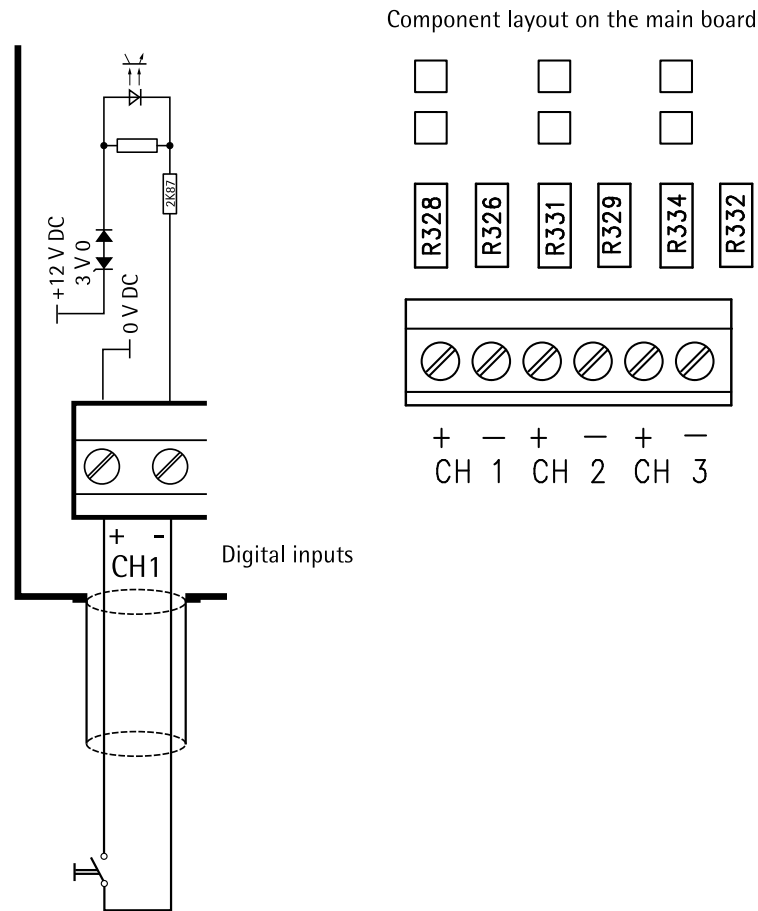

Note:

Resistors R326, R328, R329, R331, R332, and R334 are 0 Ω links.

4.4.8 Digital outputs

4.4.8.1 Relay outputs

The main board has three digital outputs for process control with potential-free two-way contacts (order code "DA1").

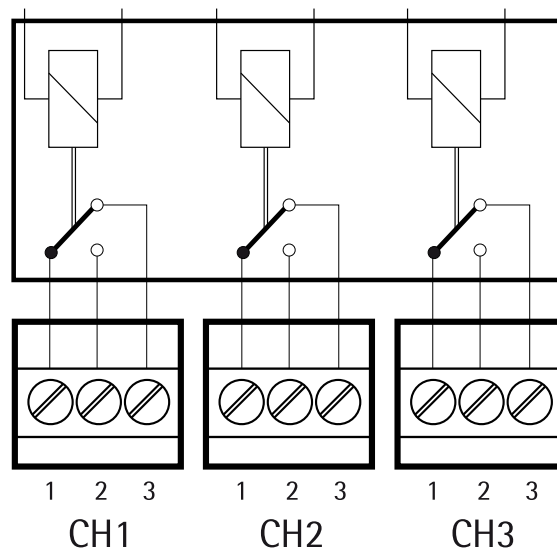
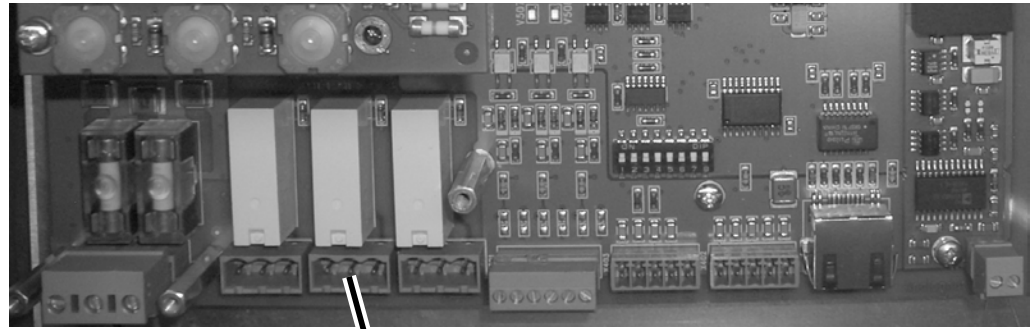

Specifications

Description	Data
Connection	3× terminal, 3-pin
Number of outputs	3 (CH1, CH2, CH3)
Output	Two-way contact Max. switching voltage: Max. switching current: U _{AC} = 250 V 0.5 A 1250 VA U _{DC} = 250 V 0.3 A U _{DC} = 100 V 0.5 A U _{DC} = 50 V 1.5 A U _{DC} = 30 V 5.0 A
Potential isolation	Free relay two-way contact
Cables	Screened Connect cable screen (wire gauge max. 1.5 mm ²) to the sleeve of the cable gland.
Cable length	max. 50 m

Component layout on the main board

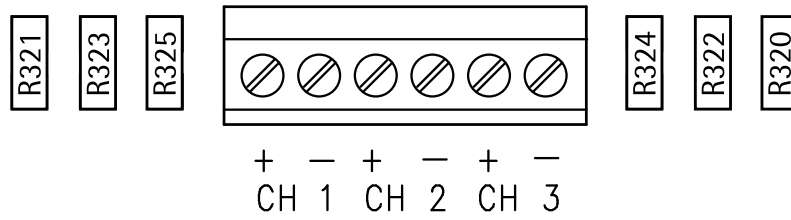

In this option jumpers R320...R325 are fitted on the main board.

Example:

Current output

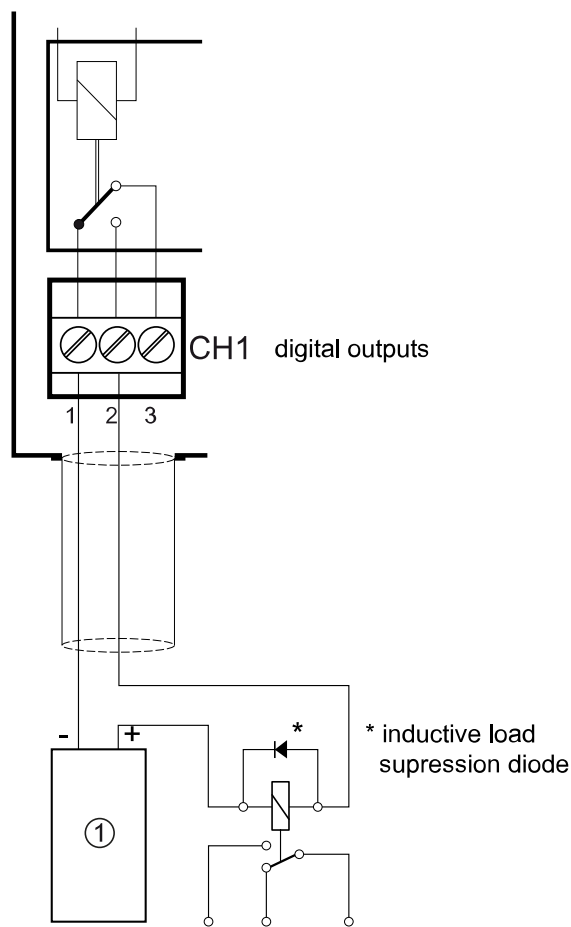

① Supply unit $U_{DC} = 24\text{ V } 0.5\text{ A}$

The relay switches when the output 1 is active (true).

To protect the output circuit, relays must be equipped with free-wheel diodes.

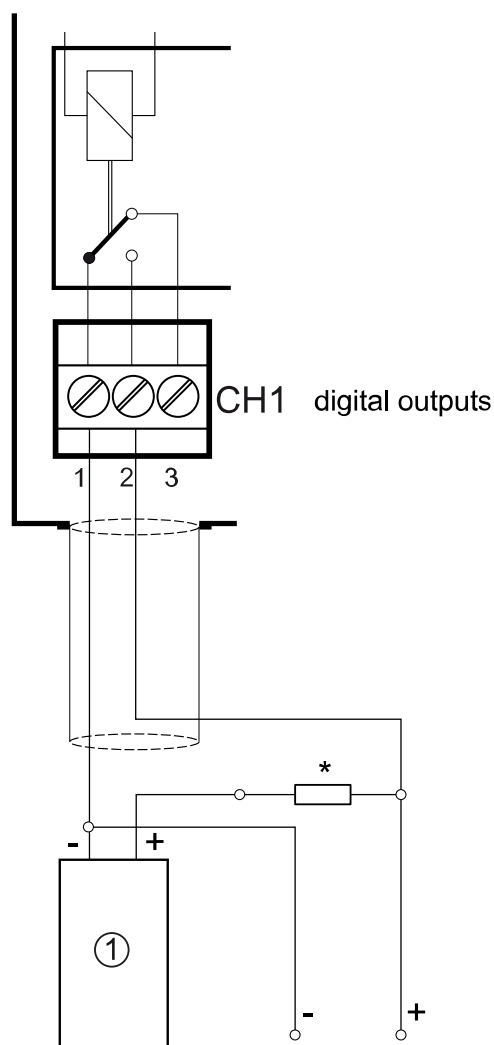
Example:**Voltage output**

① Supply unit $U_{DC} = 24\text{ V } 0.5\text{ A}$

When the output 1 is active (true), the output voltage drops from $U_{DC} = 24\text{ V}/U_{DC} = 12\text{ V}$ to $U_{DC} = <3\text{ V}$.

* The load resistance must be $2.2/1\text{ k}\Omega$.

4.4.8.2 Opto-decoupled outputs

This option (order code "DA2") can be used within Ex areas Zone 2 and Zone 22; see also Option Y2.

The main board has three opto-decoupled outputs.

The digital outputs are passive. An external power supply is required.

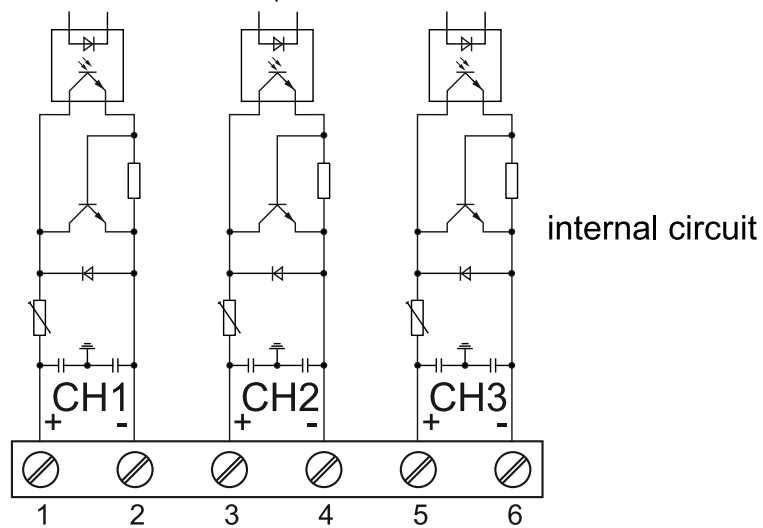
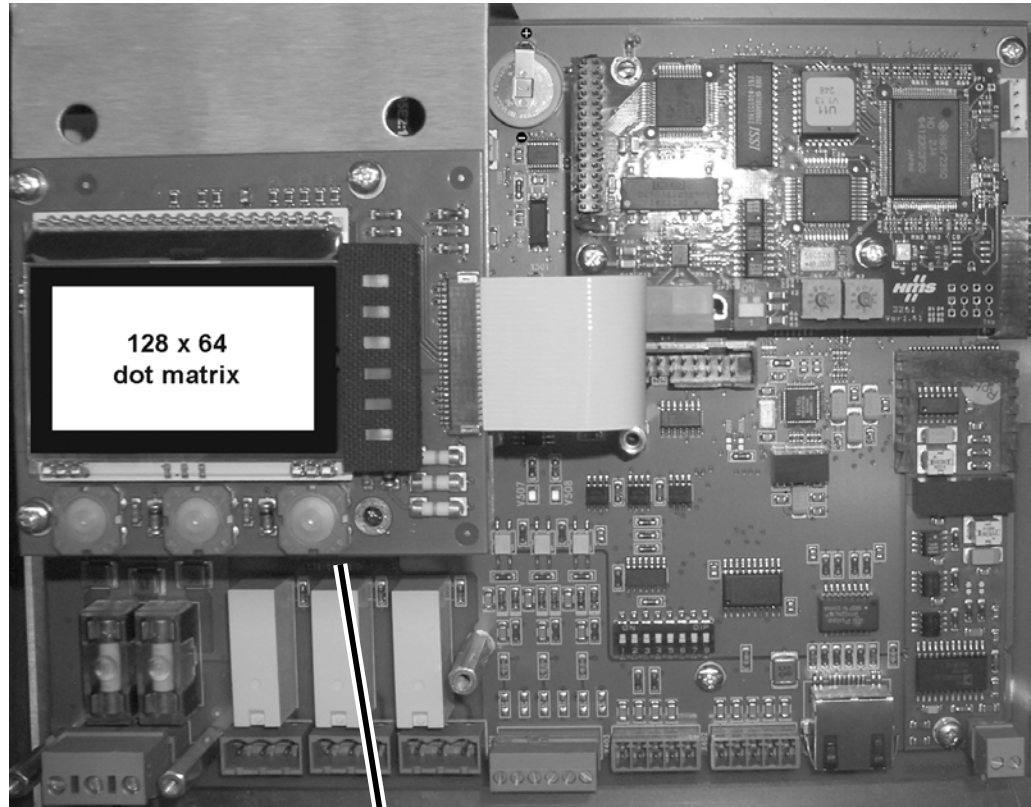

Specifications

Description	Data
Connection	Terminal, 6-pin
Number of outputs	3 (CH1, CH2, CH3)
Output voltage	max. 24 V +10% External supply

Description	Data
Output current	Max. 40 mA
Voltage drop	3.2 V @ I _{max}
Cables	Screened Connect cable screen (wire gauge max. 1.5 mm ²) to the sleeve of the cable gland.
Cable length	max. 50 m

Component layout on the main board

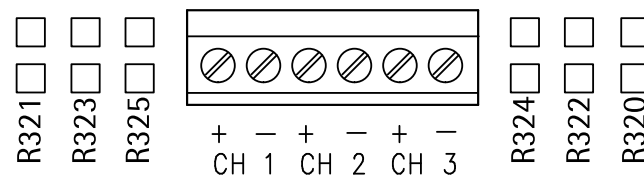

In this option, jumpers R320...R325 are **not** fitted on the main board.

4.5 Connection of analog load cells and weighing platforms

4.5.1 General information

Load cells or analog platforms (e.g. from the CAPP series) can be connected.
The supply voltage is protected against short circuit and overload.

Note:

The colors listed here apply for the Minebea Intec load cell and connection cables of type "PR ..."

Color code

bk	=	Black
bu	=	Blue
gn	=	Green
gy	=	Gray
rd	=	Red
wh	=	White

For additional information on the connection of load cells and cable junction boxes, refer to the corresponding installation manuals.

4.5.2 Connecting a load cell with a 4-wire cable

The following links between the terminal contacts are provided:

- ① from Sense S+ to Supply V+
- ② from Sense S- to Supply V-

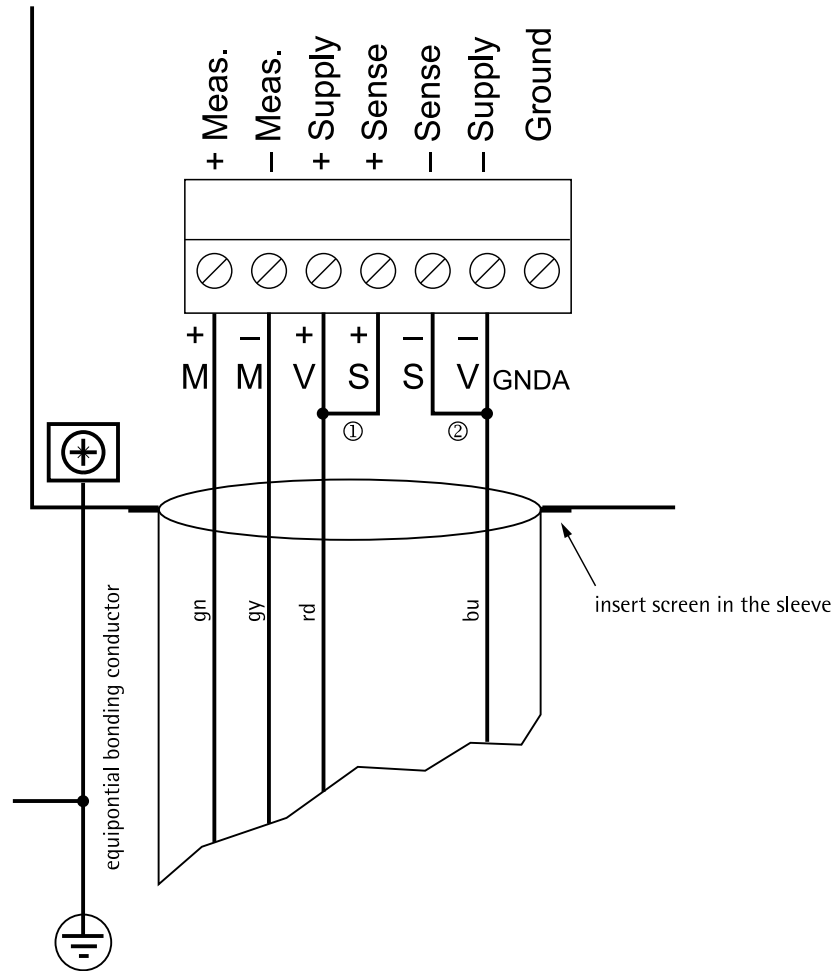

Terminal	Connection/color code	Description
M+	+ Meas./gn	+ Measuring voltage (load cell output)
M-	- Meas./gy	- Measuring voltage (load cell output)
S+	+ Sense	+ Sense voltage
S-	- Sense	- Sense voltage
V+	+ Supply/rd	+ Supply voltage
V-	- Supply/bu	- Supply voltage
GNDA	Ground analog	Screen (ground)

4.5.3 Connecting a load cell with a 6-wire cable

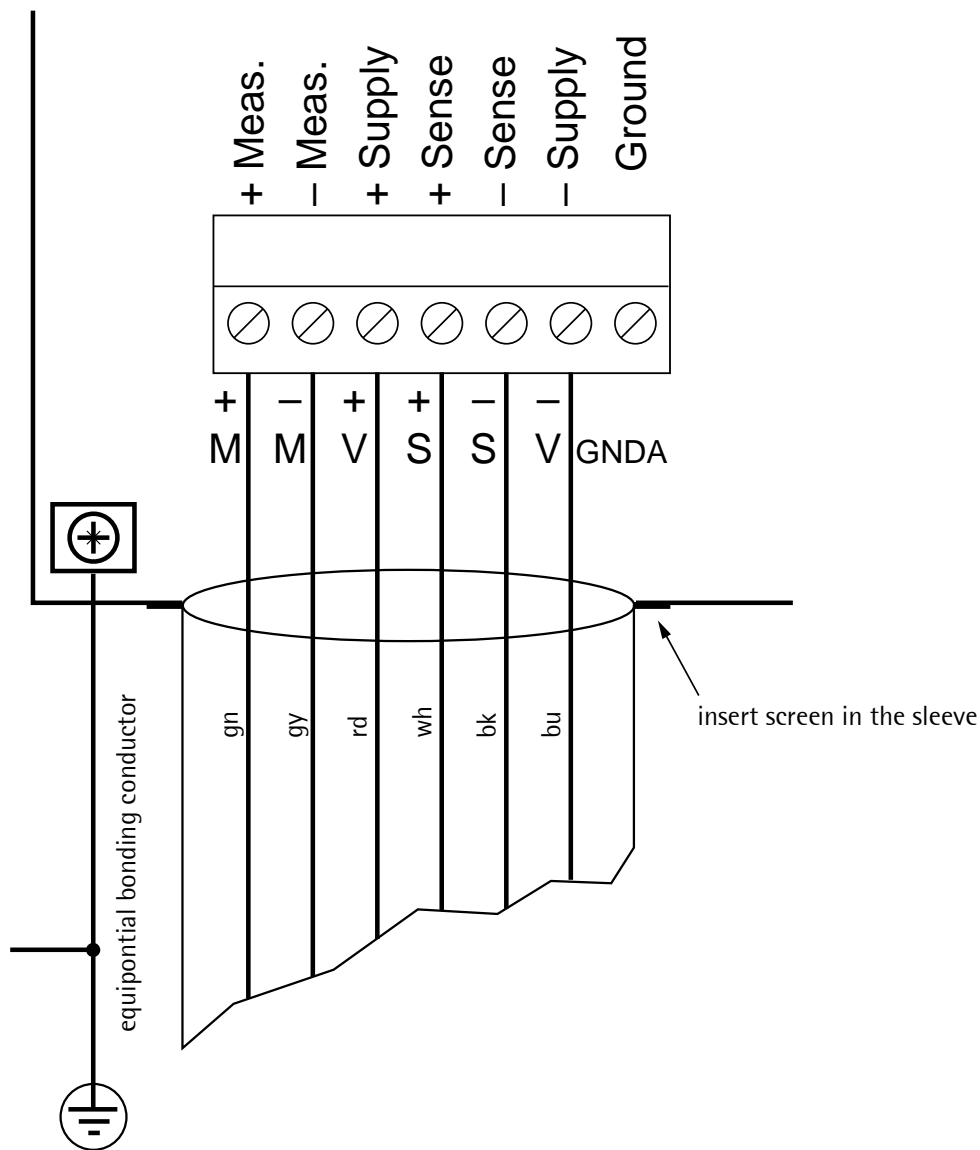

Terminal	Connection/color code	Description
M+	+ Meas./gn	+ Measuring voltage (load cell output)
M-	- Meas./gy	- Measuring voltage (load cell output)
S+	+ Sense/wh	+ Sense voltage
S-	- Sense/bk	- Sense voltage
V+	+ Supply/rd	+ Supply voltage
V-	- Supply/bu	- Supply voltage
GNDA	Ground analog	Screen (ground)

4.5.4 Connecting between 2 and 8 load cells (650 Ω) using a 6-wire connection cable

Connections are made via cable junction box PR 6130/.. using connection cable PR 6135/.. or PR 6136/... .

Load cell supply circuit

- Load resistance of load cell circuit $\geq 75 \Omega$, e.g., 8 load cells of 650 Ω each
- The supply voltage is fixed at $U_{DC} = 12 \text{ V}$ and protected against short circuits.

For further technical data, see Chapter [4.4.3](#).

Note:

If hum interference occurs, the cable screens should only be connected on one side.

Depending on the design of the cable junction box used, either the jumper J3 must be removed or the cable screens must be disconnected from the terminal contacts highlighted in yellow.

Connection example

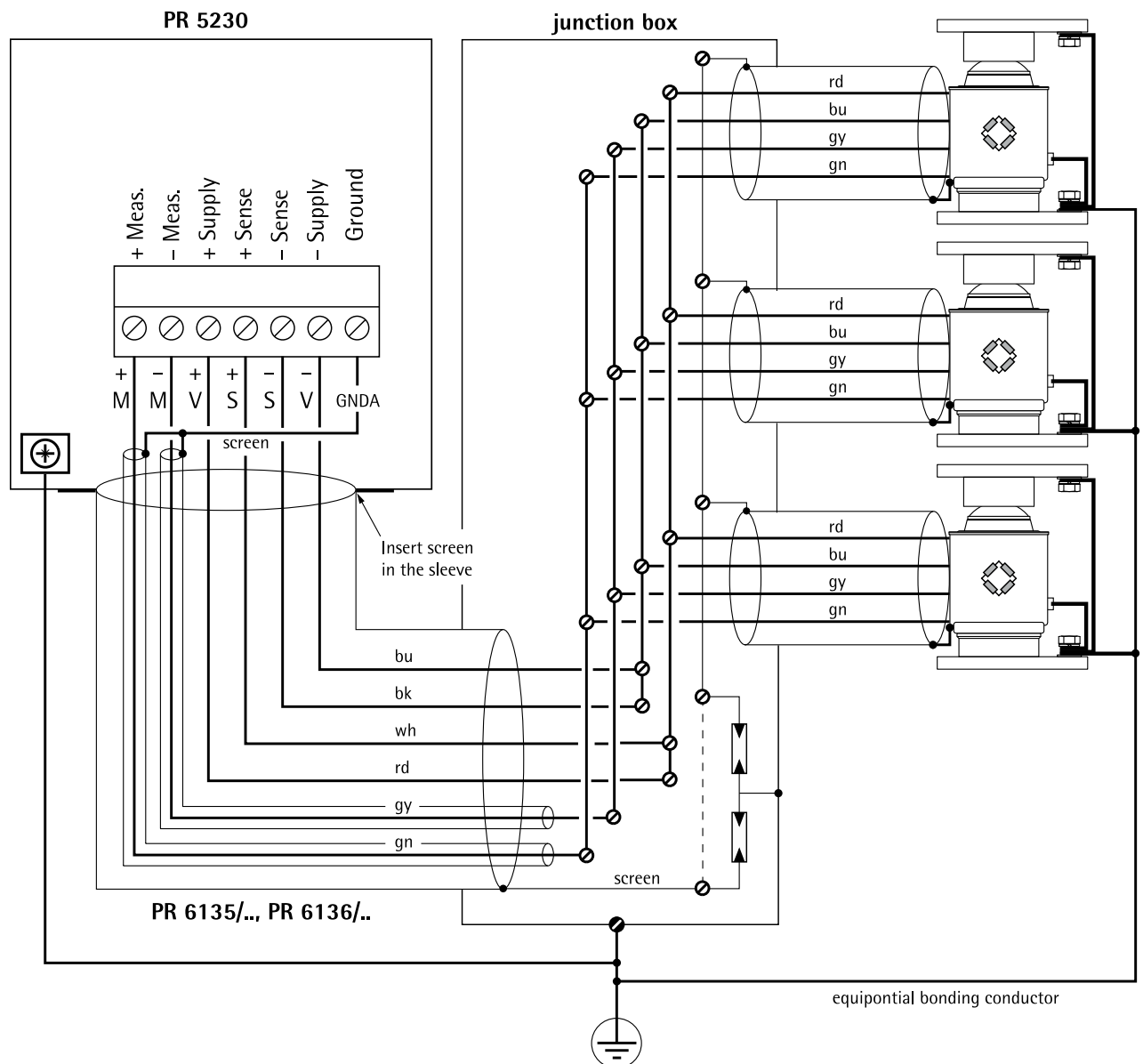

4.5.5 Connecting load cells of type series PR 6221

See installation manuals of PR 6221 and PR 6021/08, ../18, ../68S.

4.5.6 Testing the measuring circuit

A simple test with the load cells connected can be carried out with a multimeter.

Note:

In the case of an external load cell supply voltage or use of an isolating unit, the internal load cell supply is not relevant.

Measuring voltage

0–12 mV = @ LC with 1.0 mV/V
 0–24 mV = @ LC with 2.0 mV/V

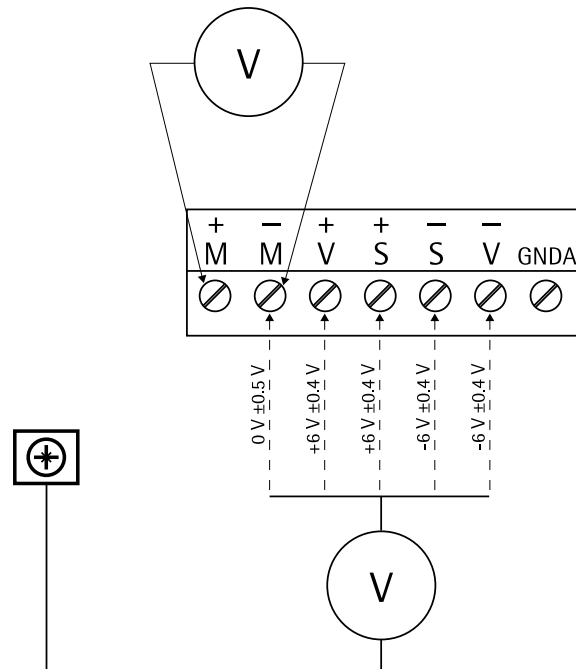

4.5.7 External supply to load cells

If the total resistance of the load cells is $\leq 75 \Omega$ (e.g., more than 4 load cells with 350Ω), an external load cell supply is required. In this case, the internal supply is replaced by a potential-free external supply.

The center of the external supply voltage (0 ext. supply) should be connected to GND A to ensure that the voltage reacts symmetrically to 0.

The internal supply is not connected.

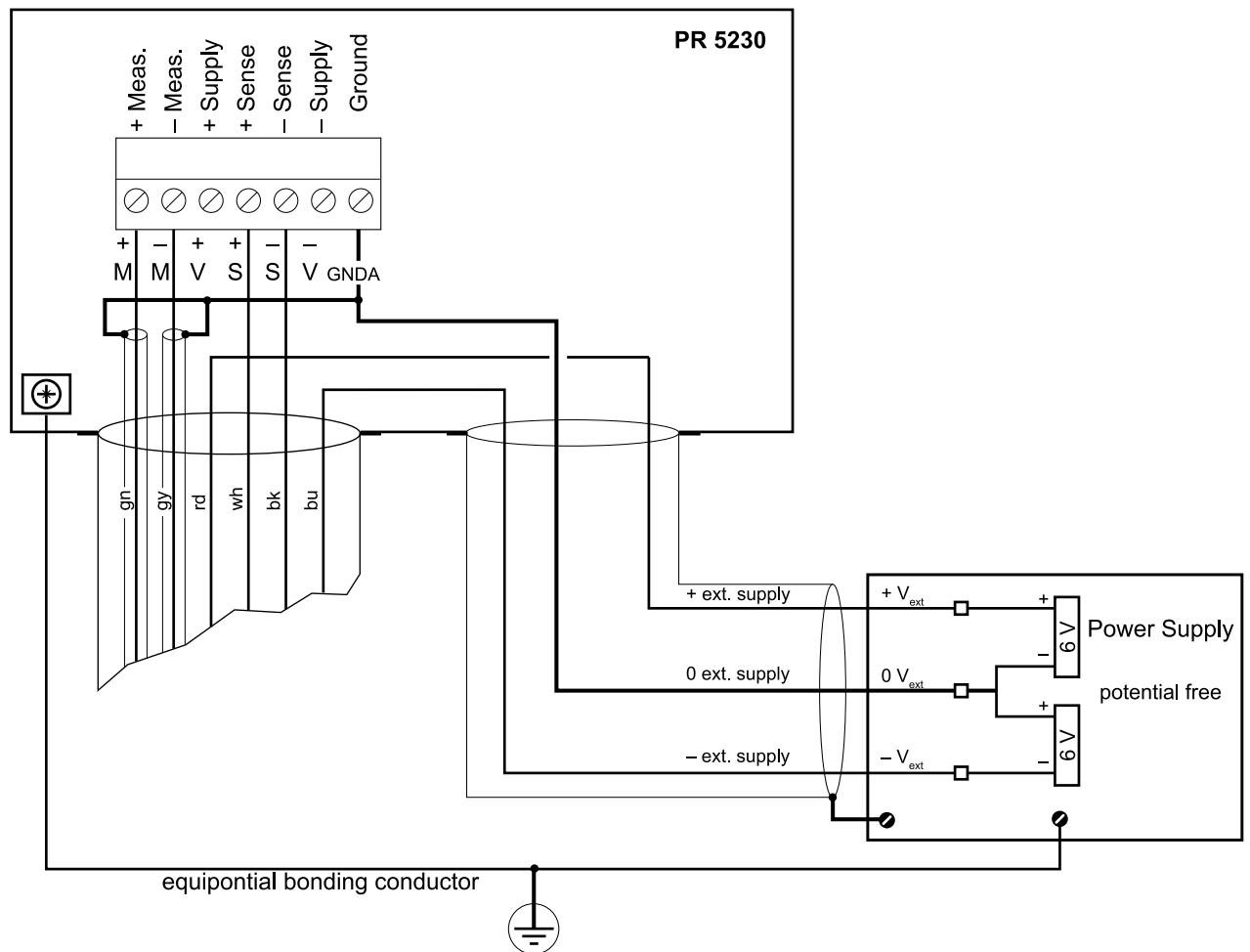
Connection example**4.5.8 Connecting 2...4 load cells via PR 5230/22 load cell junction board**

The PR 5230/22 load cell junction board for 2 to 4 load cells, which is available as an accessory, can be used instead of a cable junction box.

This is an advantage, if the PR 5230 is installed in the immediate vicinity of the load cells and the load cell cables are long enough for connection.

The load cell cables are passed through the metal cable glands.

4.5.8.1 Connecting load cells with a 4-wire cable

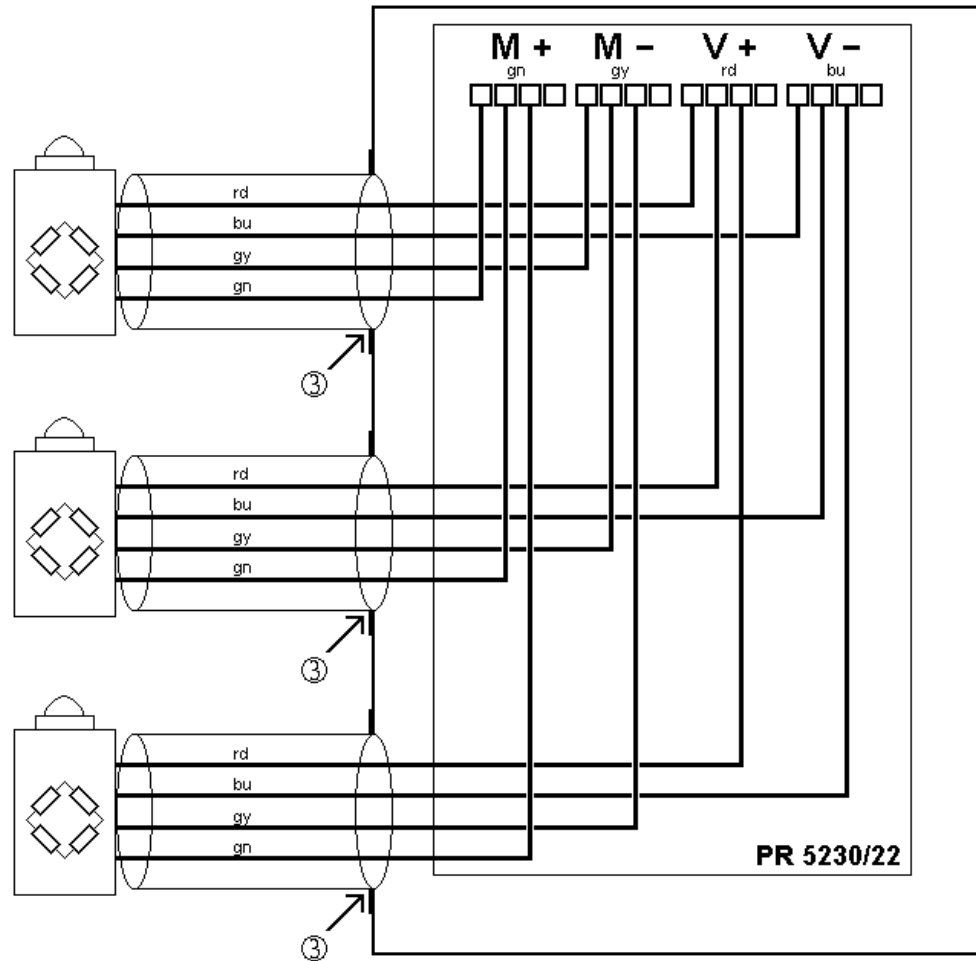

The load cell cable screens ③ are connected in the metal cable glands; see Chapter [4.2.4](#). The 4 load cell cores are color-coded:

Terminal	Port/color code	Description
M+	+ Meas./gn	+ Measuring voltage (load cell output)
M-	- Meas./gy	- Measuring voltage (load cell output)
V+	+ Supply/rd	+ Supply voltage
V-	- Supply/bu	- Supply voltage

Note:

The load cells are connected directly. Corner adjustment on the load cell junction board is not provided.

4.5.8.2 Connecting load cells with a 6-wire cable

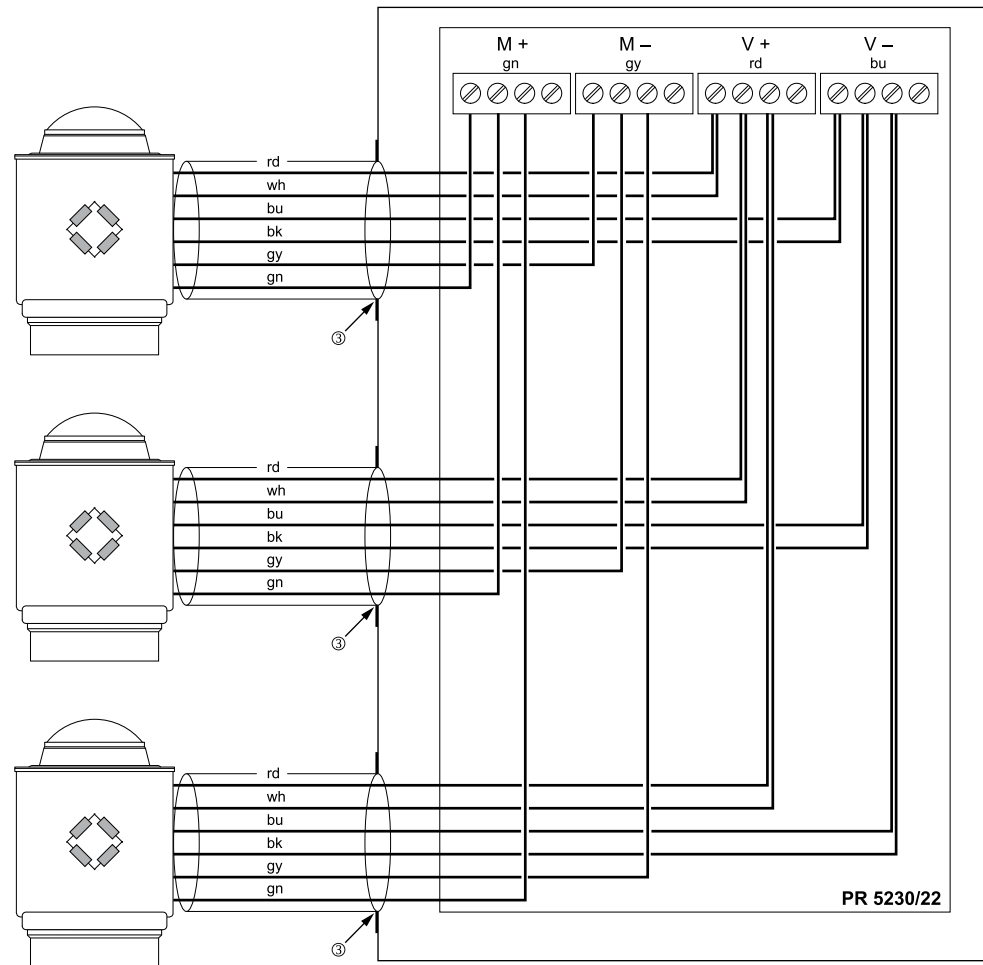

The load cell cable screens ③ are connected in the metal cable glands; see Chapter [4.2.4](#).
The 6 load cell cores are color-coded:

Terminal	Port/color code	Description
M+	+ Meas./gn	+ Measuring voltage (load cell output)
M-	- Meas./gy	- Measuring voltage (load cell output)
V+	+ Supply/rd	+ Supply voltage
	+ Sense/wh	+ Sense voltage
V-	- Supply/bu	- Supply voltage
	- Sense/bk	- Sense voltage

Note:

The load cells are connected directly. Corner adjustment on the load cell junction board is not provided.

4.5.9 Connecting an analog weighing platform (CAP... series)

You can connect an analog weighing platform to the device.

NOTICE

The cable colors shown here are valid, for example, for a CAPP4 500 x 400 and a CAPP1 320 x 420.

- ▶ The assignments of cable colors are listed in the relevant weighing platform operating instructions.

Connection designations

Combics 1 to 3 devices	PR 5230
BR_POS	V+ Supply
SENSE_POS	S+ Sense
OUT_POS	M+ Meas.
OUT_NEG	M- Meas.
SENSE_NEG	S- Sense
BR_NEG	V- Supply

The cable screens must be connected in the cable gland of the device. If the measuring lines (+M, -M) are screened individually, these screens must be connected to the "GNDA" in the terminal block.

Example:

Platform with 4-wire connection

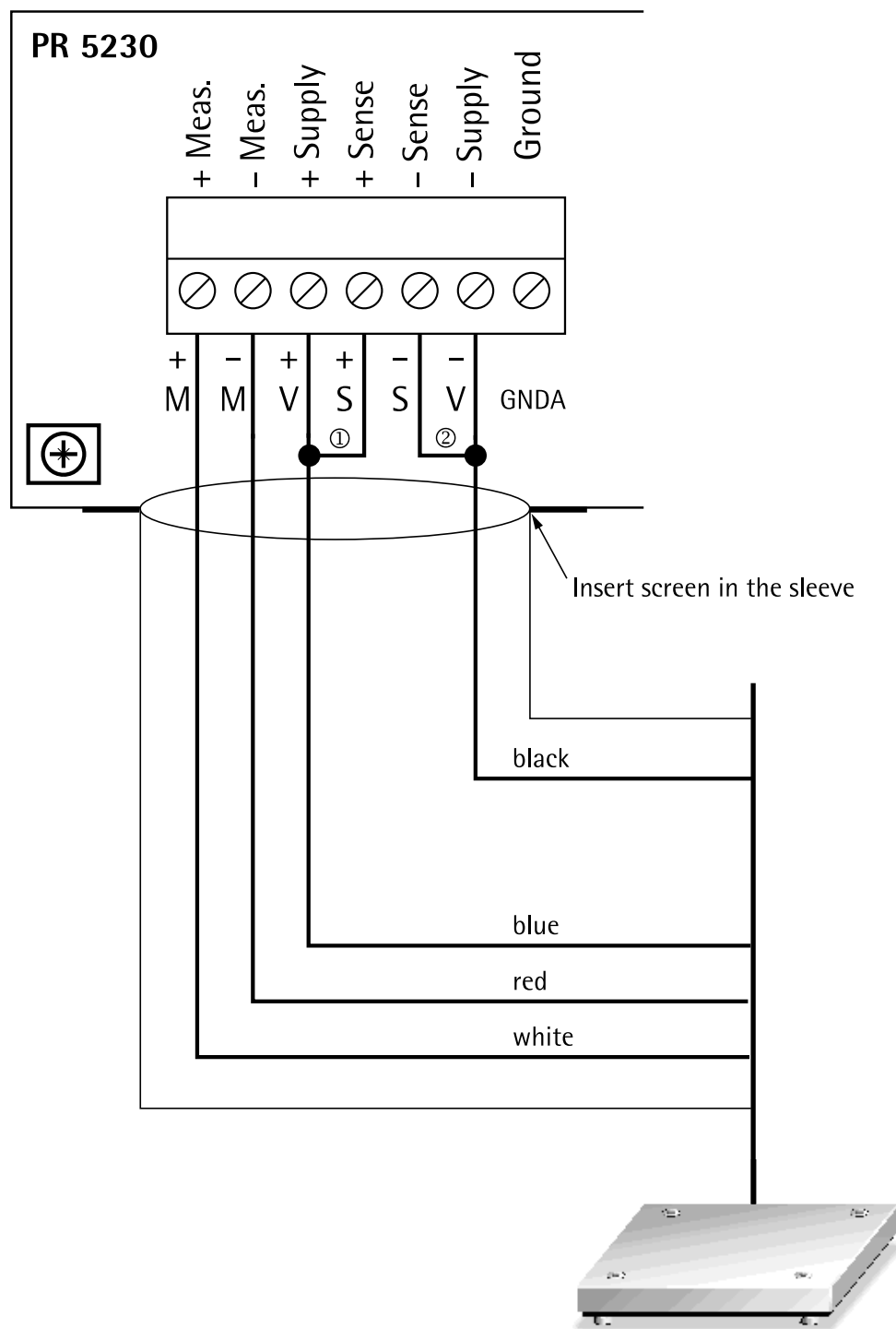

The following links between the terminal contacts are provided:

- ① from Sense S+ to Supply V+
- ② from Sense S- to Supply V-

Example:

Platform with 6-wire connection

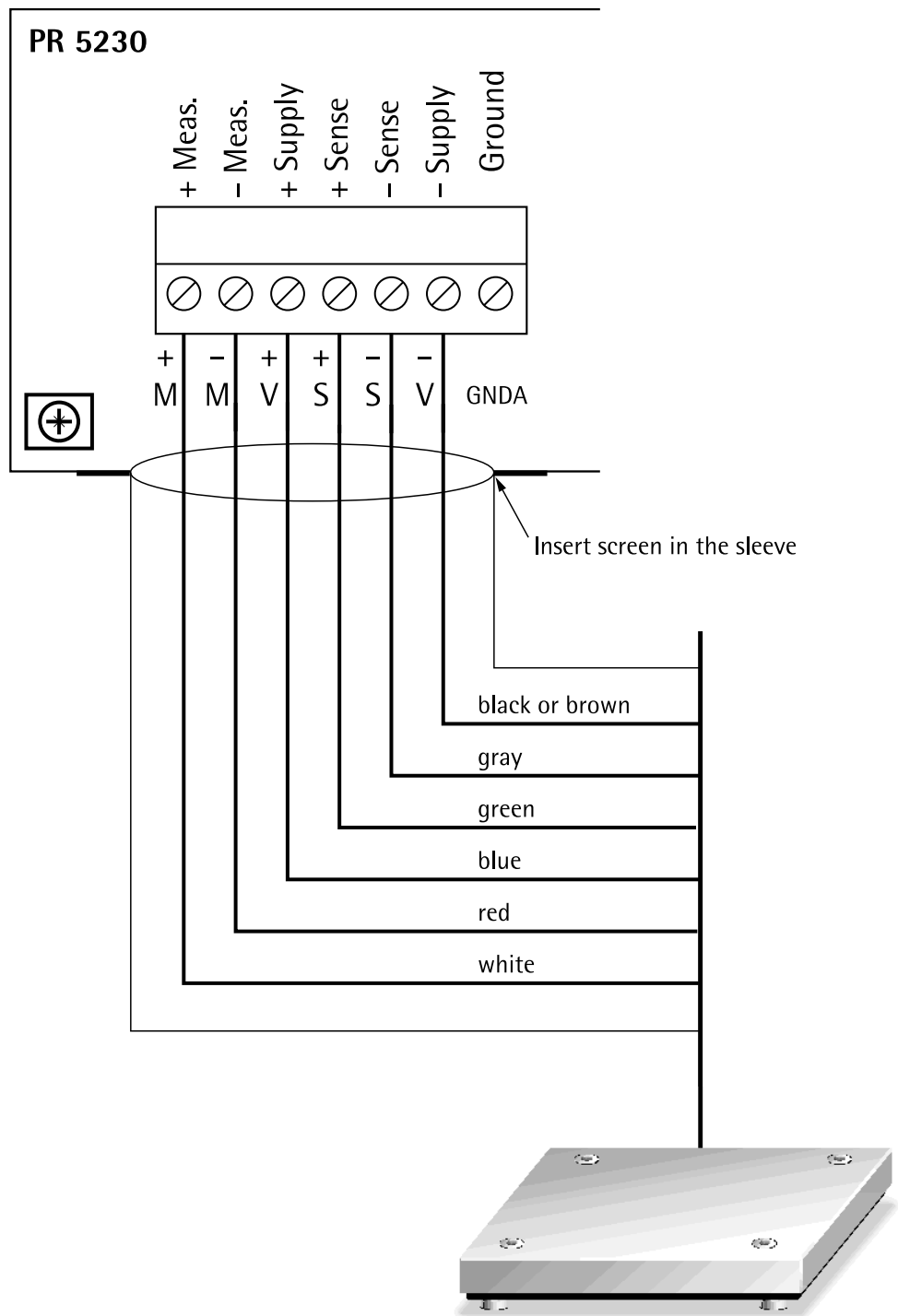

4.6 Accessories

4.6.1 General information

The main board has three additional function-specific slots. These slots can accommodate the following cards:

- "Slot 1": PR 5230/06 analog output board (see Chapter [4.6.2](#))
- "Slot 2": PR 1721/4x (fieldbus card)
- "Slot 3": PR 5230/22 load cell junction board (see Chapter [4.6.3](#))

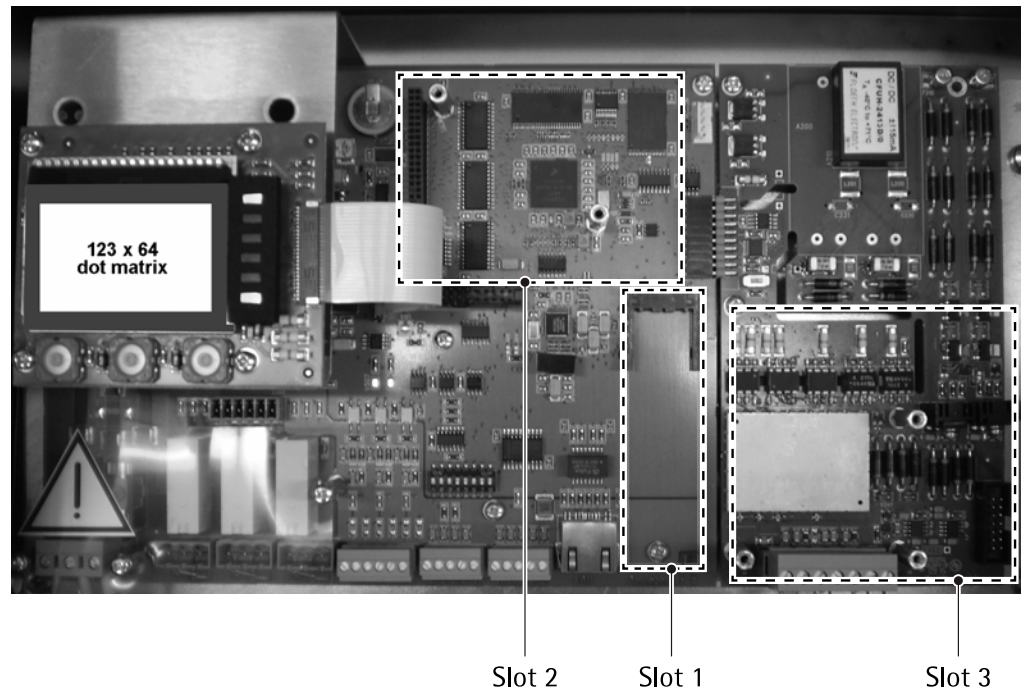

⚠ WARNING

Working on the device while it is switched on may have life-threatening consequences.

- ▶ Before installing or removing a plug-in card, the device must be disconnected from all voltage sources.

Note:

After installation/modification, the plug-in cards are detected automatically.

The installed plug-in cards, except for PR 5230/22, can be displayed via  - [Show HW-Slots]; see Chapter [7.16.3](#).

4.6.2 Analog outputs

The analog output card has the type designation PR 5230/06. It is designed with a 2-pin screw terminal for an active analog output. The card is inserted into "Slot 1" (see Chapter 4.6.1).

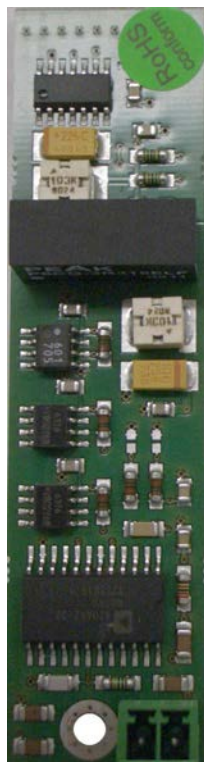

Technical data

Description	Data
Connection	Terminal, 2-pin
Output: Number	1 active current output: 0/4...20 mA (max. 24 mA), 10 V output voltage via external 500 Ω resistor
Output: Function	according to gross weight/net weight/display, configurable
Output: Range	0/4... to 20 mA, configurable
Output: Resolution	Internal 16 bits = 65536 counts, resolution of 20,000 @ 20 mA
Output: Linearity error	@ 0 to ...20 mA: <0.04 % @ 4 to ...20 mA: 0.02 %
Output: Temperature error	<100 ppm/K
Output: Zero point error	0.05%
Output: Max. error	<0.1 %
Output: Load	Max. 0... to 500 Ω

Description	Data
Output: Protected against short-circuit	yes
Output: Potential isolation	yes
Cable type	Screened twisted pair (e.g., LifYCY 2x2x0.20)
Cable length	<150 m screened
Accessories	Mounting screw M3x12, Spacer ring 3 mm thick

Analog signal "current output"

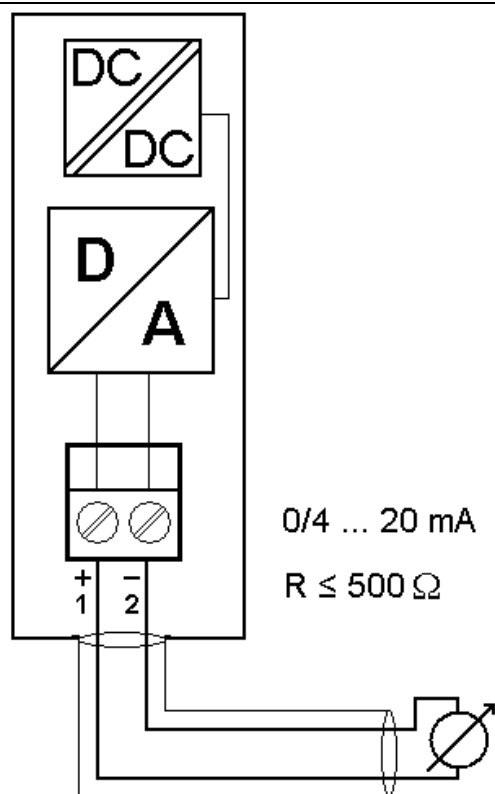

Current is supplied directly via the terminal contacts.

Analog signal "voltage output"

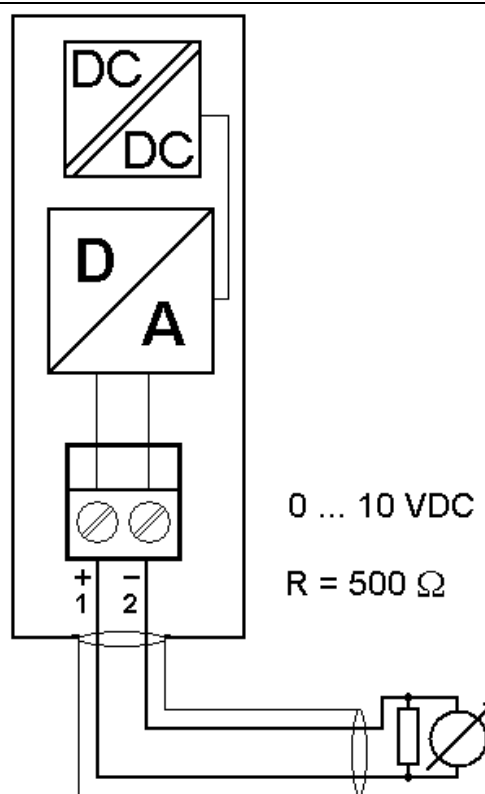

The voltage level corresponds to the voltage drop at the external 500 Ω resistor.

4.6.3 Load cell junction board

The load cell junction board has the type designation PR 5230/22. The board is connected to the weighing electronics board by a ribbon cable and is plugged into "slot 3" (see Chapter 4.6.1).

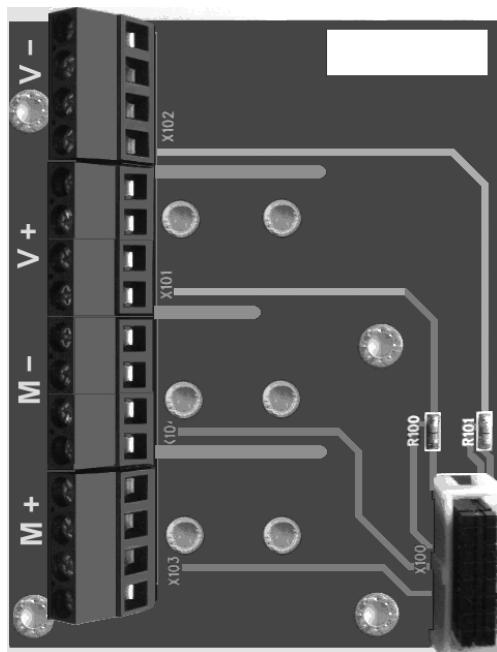

Specifications

Description	Data
Connection	Terminal, 4x 4-pin
Number of load cells	1...4
Load cell type	Strain gauge, 6 or 4-wire connection possible

4.6.4 Status LEDs on fieldbus card



Watchdog LED

Frequency	Color	Meaning
Flashing 1 Hz	green	Module is initialized and ready for operation.
Flashing 2 Hz	green	Module is not initialized.
Flashing 1 Hz	red	Check error in ASIC and FLASH ROM: Module is defective.

4.6.5 ProfiBus DP interface

The ProfiBus DP interface card has the type designation PR 1721/41.

Communication protocols and syntax comply with the ProfiBus-DP standard to IEC 61158, with transfer rates up to 12 Mbit/s.

Connection to the ProfiBus is established using the 6-pole terminal in the device.

The card is inserted into "Slot 2" ① (see Chapter 4.6.1).

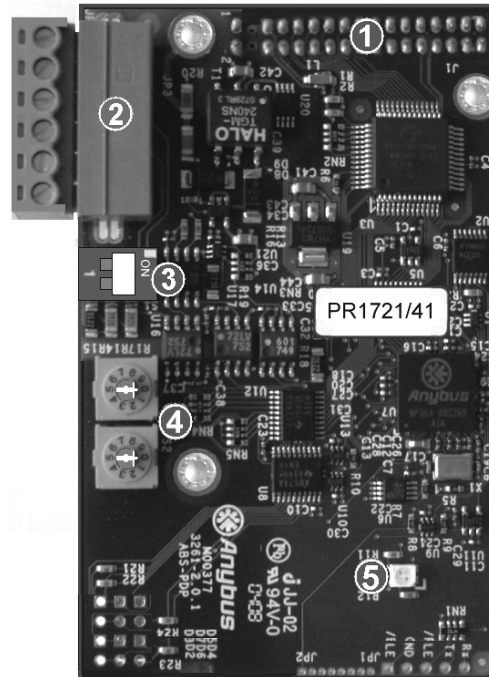

Technical data

Description	Data
Transfer rate	9.6 kbit/s to 12 Mbit/s, baud rate auto-detection
Connection mode	Profibus network, connections can be made/released without affecting other stations.
Protocol	PROFIBUS-DP-V0 SLAVE to IEC 61158 <ul style="list-style-type: none"> - Mono or multi-master systems are supported. - Master and slave devices, max. 126 nodes possible. - Watchdog Timer ⑤ (see Chapter 4.6.4)
Configuration	GSD file "SART5230.gsd"
Potential isolation	Yes, optocoupler in lines A and B (RS-485)
Bus termination	Via bus terminating resistor switch ③ (see Chapter 4.6.5.3)
Addressing	Via software Turn switch ④ must be set to position 0.
Cable type	Profibus "special"; color: violet; screened twisted pair cable
Cable impedance	150 Ω
Cable length	The max. distance of 200 m can be extended at 1.5 Mbit/s by means of an additional repeater.
Certificates	Profibus test center Comdec in Germany and PNO (Profibus User Organization). Industry-compatible CE, UL, and cUL

Note:

The GSD file is stored on the CD supplied with the device (fieldbus directory of the respective device). The current file is also available to download online:

<http://www.minebea-intec.com>

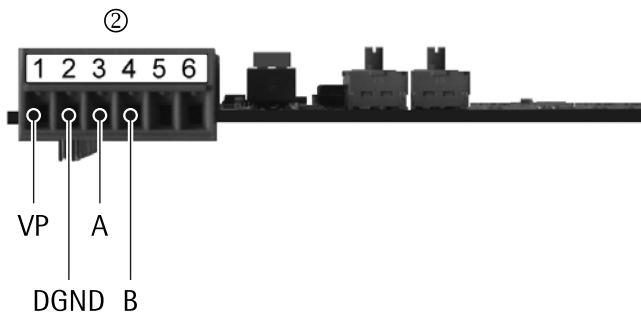
ProfiBus-DP terminal**Allocation of the 6-pin terminal**

Pin assignment	Signal	Color	Description
Cable sheath		Violet	Special ProfiBus cable (certified)
1 -----	VP		Insulated power supply +5 V to RS-485 side
2 -----	DGND		Insulated GND to RS-485 side
3 -----	RxD/TxD-N (negative) ac- cording to RS-485 specifi- cation	Green	Send/receive data Data core A
4 -----	RxD/TxD-P (positive) ac- cording to RS-485 specifi- cation	Red	Send/receive data Data core B
5			Not connected
6			Not connected

4.6.5.1 Controls on fieldbus card



The terminating resistors can be switched on (ON) and off by pressing the bus termination switch ③; see Chapter [4.6.5.3](#).



NOTICE



The ④ rotary switch settings will not be used.

- ▶ Ensure that the three rotary switches for node address 1...99 are set to position "0."

Settings are defined via  - [Fieldbus parameter][Profibus-DP].

4.6.5.2 Status indicator

Requirements:

- The items are defined via  - [Display items]- [Fieldbus LEDs]; see Chapter [7.15.7](#).
- PR 1721/41 is selected via  - [HW-Slots]- [Slot 2].

Display:

	1	2	3	4
LED	---	---	---	---

1	2	3	4
Constant ---: No function	Constant grn : Module is online, data transmission is possible.	Flashing 1 Hz red : Input/output length configuration error.	Constant red : Fieldbus is offline, data transmission is not possible.
		Flashing 2 Hz red : User parameter error	
		Flashing 4 Hz red : Error in ASIC	

Legend

---	off
red	red
grn	green

4.6.5.3 Bus termination

The end nodes in a ProfiBus-DP network must be fitted with termination resistors, to prevent reflections in the bus cable.



Bus termination switch ③ can only be accessed when the device has been opened.

Bus termination switch "ON"

The bus termination is switched on.
If the module is the last or first in the network, this switch must be set to "ON."
An "external" terminating resistor can also be used in the ProfiBus connector, however.

Bus termination switch "OFF"

The bus termination is switched off.
When using an external terminating resistor in the ProfiBus connector, the switch on the module cover must be in position "OFF."

4.6.5.4 Connection diagram for a master with three slaves

The following connection diagram shows a ProfiBus-DP network without an external terminating resistor in the ProfiBus connector.

NOTICE

Do not guide the screens into the unit!

- ▶ The cable screens must be connected in the cable glands.
- ▶ Before, during and after installation, make sure that the sealing rings are seated correctly.

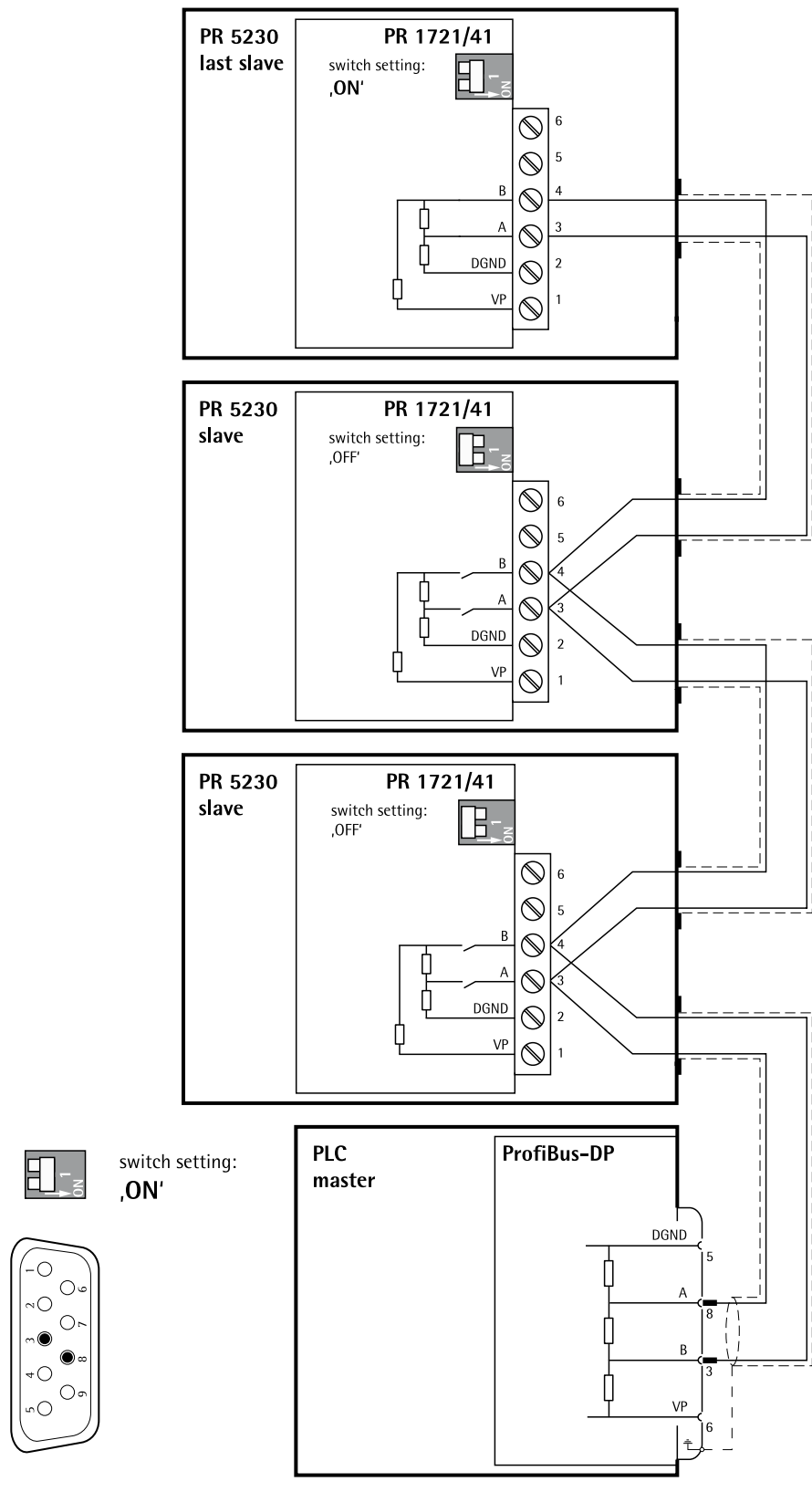

4.6.6 InterBus-S interface

The InterBus-S interface card has the type designation PR 1721/42.

The interface is based on the InterBus chip technology and enables transfer rates of 500 kbit/s.

The InterBus-S connection is established by the 6-pin (IN) ② and 7-pin (OUT) ③ terminal.

The card is inserted into "Slot 2" ① (see Chapter 4.6.1).

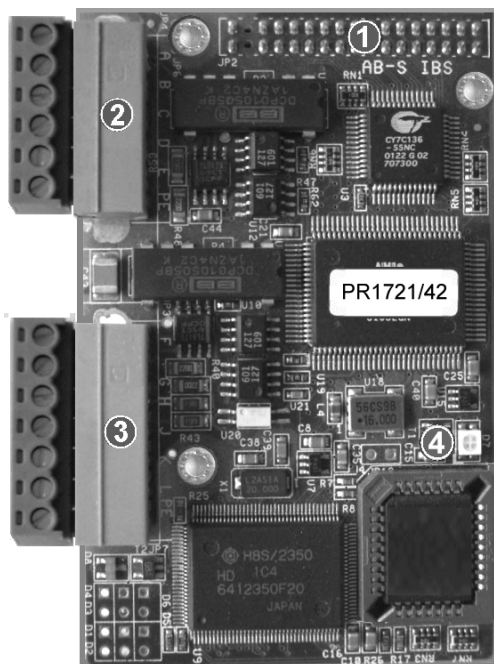

Specifications

Description	Data
Transmission rate	500 kbit/s
Protocol	Interbus-S master–slave <ul style="list-style-type: none"> - Fixed telegram length - Deterministic cyclical process data transmission with max. 10 words I/O. - Watch-Dog Timer ④ (see Chapter 4.6.4)
Potential isolation	Yes, optocoupler and DC/DC converter
Lead termination	Not required, due to active ring topology
Cable type	InterBus; color: green; 3x2 twisted pair; screened
Cable impedance	150 Ω
Cable length	400 m (between two remote bus subscribers); overall length: 13 km
Certificates	From INTERBUS CLUB e.V.: <ul style="list-style-type: none"> - Compatibility with InterBus standard. - IEC 61158 (Parts 3 to 6), EN 50254 (DIN 19258) - Industry-compatible CE, UL and cUL

InterBus-S terminals

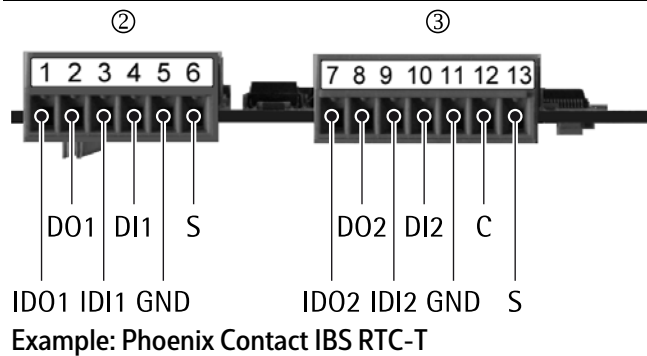

Allocation of the 6-pole terminal "IN"②

Pin allocation acc. to DIN 41642	Signal	Color acc. to DIN 47100	Description
Cable sheath		pea green	Special InterBus cable (certified)
1 -----	IDO1	green	inverted, data output
2 -----	DO1	yellow	not inverted, data output
3 -----	IDI1	pink	inverted, data input
4 -----	DI1	gray	not inverted, data input
5 -----	GND	brown	signal ground
6 -----	S		Screen



Allocation of the 7-pole terminal "OUT"③

Pin allocation acc. to DIN 41642	Signal	Color acc. to DIN 47100	Description
Cable sheath		pea green	Special InterBus cable (certified)
7 -----	IDO2	green	inverted, data output
8 -----	DO2	yellow	not inverted, data output
9 -----	IDI2	pink	inverted, data input
10 -----	DI2	gray	not inverted, data input
11 -----*	GND	brown	signal ground (continuation jumper: 11-12)
12 -----*	C		Con_Test (continuation jumper: 11-12)
13 -----	S		Screen

* only if necessary

4.6.6.1 Status indicator

Requirements:

- The items are defined via  - [Display items]- [Fieldbus LEDs]; see Chapter [7.15.7](#).
- PR 1721/42 is selected via  - [HW-Slots]- [Slot 2].

Display:

	1	2	3	4
LED	---	---	---	---

1	2	3	4
Constant grn : Cable OK, no reset mode in the master.	Constant grn : Bus is active.	Constant red : Remote bus is not active.	Constant grn : PCP communication is active, hold = 500 ms.

Legend

---	off
red	red
grn	green

4.6.6.2 Connection diagram for a master with three slaves

NOTICE

At terminal "OUT" ③, terminal contacts 11 (GND) and 12 (C) must be bridged if another slave follows.

- The terminal is left open when the last slave is connected; see connection diagram.

NOTICE

The cable screens must be guided into the instrument through the cable glands and connected to terminal "IN" ② in terminal contact 6 (S) or "OUT" ③ in terminal contact 13 (S); see connection diagram.

- Before, during and after installation, make sure that the sealing rings are seated correctly.

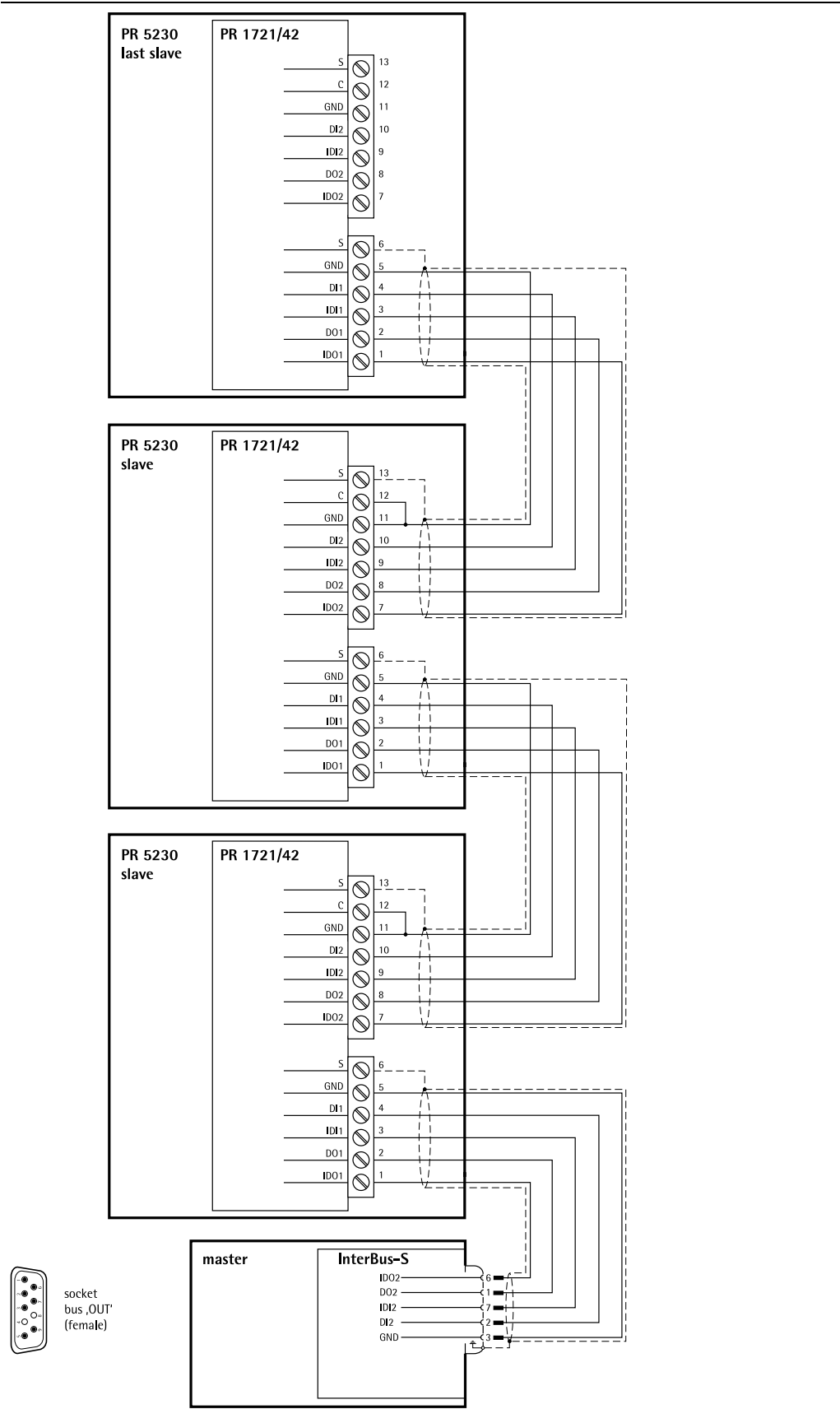

4.6.7 DeviceNet interface

The DeviceNet interface card has the type designation PR 1721/44.

The fieldbus card contains all functionalities to make a complete DeviceNet slave with a CAN controller and transmission speeds up to 500 kbit/s.

The DeviceNet connection is established by 5-pin terminal ②.

The card is inserted into "Slot 2" ① (see Chapter 4.6.1).

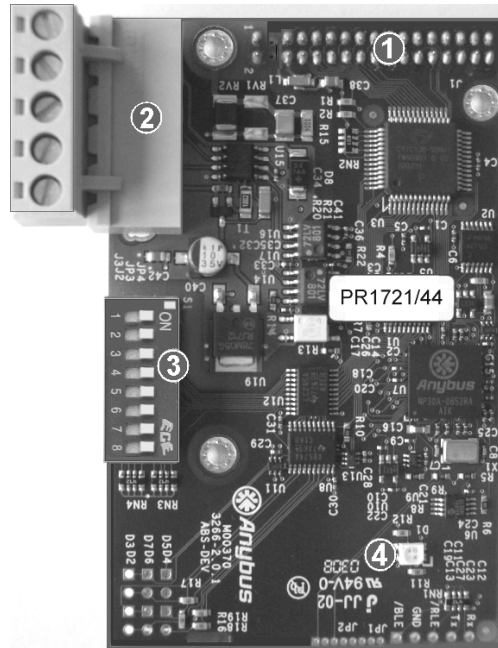

Technical data

Description	Data
Transfer rate	125, 250 and 500 kbit/s
Protocol	DeviceNet Master Slave <ul style="list-style-type: none"> - Polling procedure (polled IO) - CRC error recognition according to IEC 62026 (EN 50325) - Max. 64 station nodes - Data width max. 512 byte "input & output" - Watchdog Timer ④ (see Chapter 4.6.4)
Configuration	EDS file "sag_5230.eds" MAC-ID (1...62)
Potential isolation	Yes, optocoupler and DC/DC converter
Bus termination	120 Ω at the cable ends
Bus load	33 mA @ $U_{DC} = 24$ V
Cable type	DeviceNet; color: petrol green; 2x2 twisted pair; screened
Cable impedance	150 Ω
Cable length	Depends on cable type and transmission rate: 100 to 500 m

Description	Data
Certificates	<ul style="list-style-type: none"> - Compatible with DeviceNet specification Vol. 1: 2.0, Vol 2: 2.0 - ODVA Certificate according to conformity test software version A-12 - Industry-compatible CE, UL, and cUL

Note:

The EDS file is stored on the CD supplied with the device (fieldbus directory of the respective device). The current file is also available to download online:

<http://www.minebea-intec.com>

DeviceNet terminal

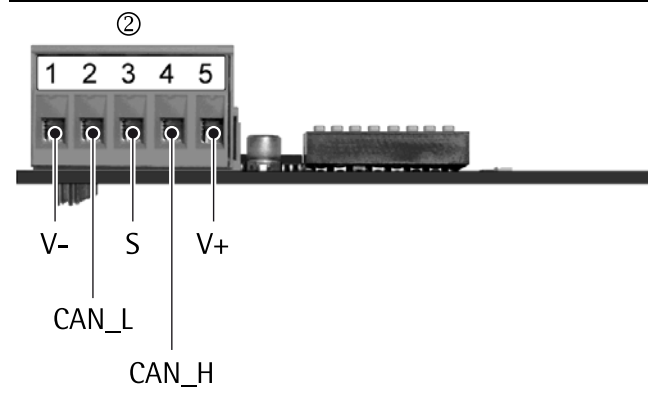

Allocation of the 5-pin terminal

Pin assignment	Signal	Color	Description
Cable sheath			Special DeviceNet cable (certified)
1 -----	V-	black	Negative power supply
2 -----	CAN_L	Blue	CAN_L bus signal
3 -----	S		Cable screen
4 -----	CAN_H	white	CAN_H bus signal
5 -----	V+	Red	Positive power supply

4.6.7.1 Controls on fieldbus card

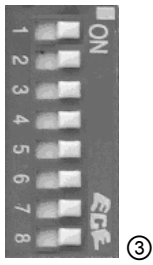

NOTICE

The ③ DIL switch settings will not be used.

- ▶ Make sure that the switches 1...8 are set to position "ON."

Settings are defined via - [Fieldbus parameter].

4.6.7.2 Status indicator

Requirements:

- The items are defined via - [Display items]- [Fieldbus LEDs]; see Chapter 7.15.7.
- PR 1721/44 is selected via - [HW-Slots]- [Slot 2].

Display:

	1	2	3	4
LED	---	---	---	---

1	2	3	4
Constant ---: No function	Constant ---: Not powered, not online.	Constant ---: No function	Constant ---: No power
	Constant grn : Link detected. Fieldbus is online and connected.		Constant grn : Module is working.
	Flashing grn : Online, not connected.		Flashing grn : Data size > configuration
	Constant red : Critical link error		Constant red : Fatal error
	Flashing red : Connection timeout		Flashing red : Minor error

Legend

---	off
red	red
grn	green

4.6.7.3 Connection diagram for a master with three slaves

NOTICE

The cable screens must be guided into the device through the cable glands and connected to terminal ② in terminal contact 3 (S); see connection diagram.

- Before, during and after installation, make sure that the sealing rings are seated correctly.

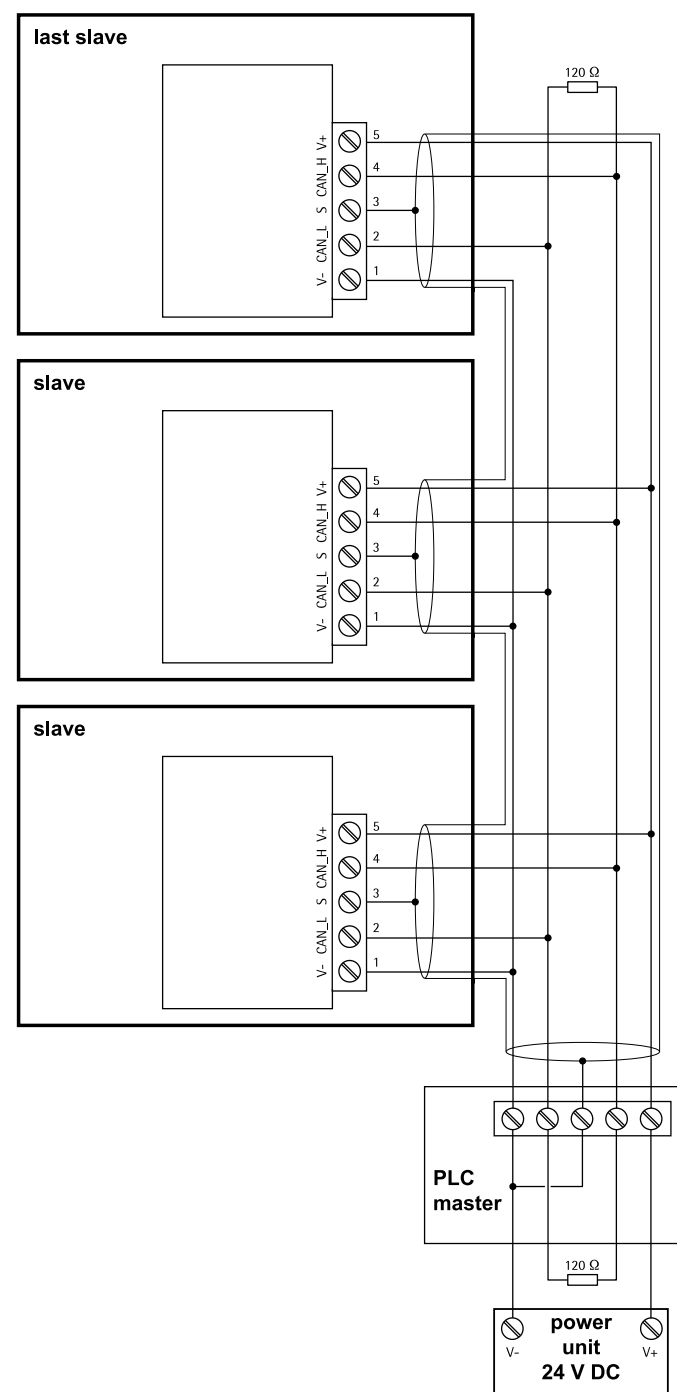

4.6.8 CC-Link interface

The CC-Link interface card has the type designation PR 1721/45.

The fieldbus card contains all functions to provide a complete CC-Link slave with transfer rates up to 10 Mbps.

The CC-Link connection is established by the 5-pin terminal ②.

The card is inserted into "Slot 2" ① (see Chapter 4.6.1).

Note:

This fieldbus card does **not** support the "EasyFill" application.

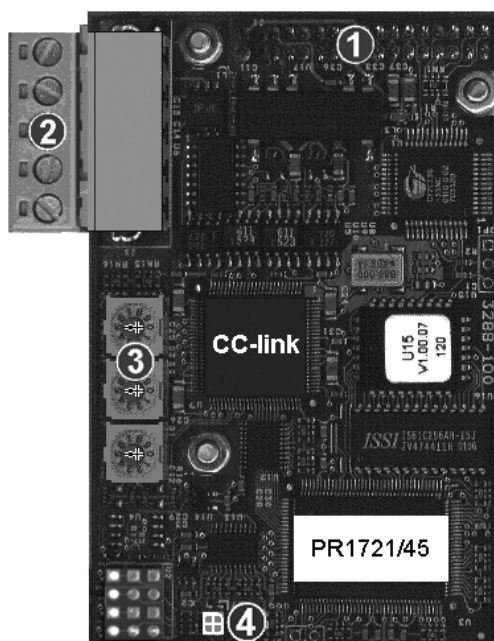

Technical data

Designation	Data
Transfer rate	156; 625 kbps; 2.5; 5, 10 Mbps
Protocol	CC-Link slave <ul style="list-style-type: none"> - CRC error recognition according to IEC 62026 (EN 50325) - Max. 64 station nodes - 128 I/O bits and 16 (32 bit) words - Watchdog Timer ④ (see Chapter 4.6.4)
Configuration	CSP file "PR1721_1.csp"
Potential isolation	Yes, optocoupler and DC/DC converter
Bus termination	110 Ω at the cable ends
Bus load	100 mA
Cable type	2x2 screened twisted pair
Cable length	100 m @ 10 Mbps, 1200 m @ 156 kbps

Designation	Data
Certificates	- Type: ABS-CCL (H/W: 1.01, S/W: 2.00.05, CC-Link: 2.0) - Reference no. 372

Note:

The CSP file is stored on the CD supplied with the device (Fieldbus directory of the respective device). The current file is also available for download via the Internet:

<http://www.minebea-intec.com>

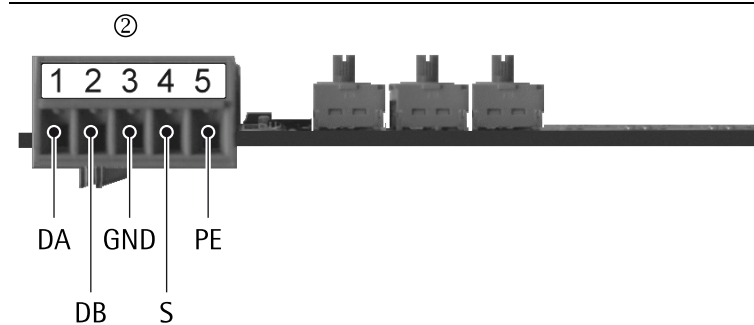
CC-Link terminal**Allocation of the 5-pole terminal block**

Pin assignment	Signal	Description
1-----	DA	Communication RS-485 RxD/TxD (+)
2-----	DB	Communication RS-485 RxD/TxD (-)
3-----	GND	Digital ground
4-----	S	Cable screen
5-----	PE, according to AnyBus S-specification	Housing ground

4.6.8.1 Controls on fieldbus card**NOTICE**



The ③ rotary switch settings will not be used.

- ▶ Ensure that the three rotary switches (station no. and baud rate) are set to position "9."

This setting is defined via  - [Fieldbus parameter] [CC-Link].

4.6.8.2 Status indicator

Requirements:

- The items are defined via  - [Display items]- [Fieldbus LEDs]; see Chapter [7.15.7](#).
- PR 1721/45 is selected via  - [HW-Slots]- [Slot 2].

Display:

	1	2	3	4
LED	---	---	---	---

1	2	3	4
Constant ---: No power	Constant ---: No power	Constant ---: No power	Constant ---: No power
Constant grn : Normal function	Constant red : CRC error, inadmis- sible station or baud rate.	Constant grn : Send data.	Constant grn : Receive data.

Legend

---	off
red	red
grn	green

4.6.8.3 Connection

NOTICE

The cable screen must be guided into the instrument through the cable gland and connected to terminal ② in terminal contact 4 (S).

- Before, during and after installation, make sure that the sealing rings are seated correctly.

4.6.9 ProfiNet I/O interface

The ProfiNet I/O interface card has the type designation PR 1721/46.

The fieldbus card is equipped with a standard RJ-45 socket ② for network connection. It contains powerful UDP/IP connecting circuitry with transfer rates of 10 and 100 Mbit/s. The card is inserted into "Slot 2" ① (see Chapter [4.6.1](#)).

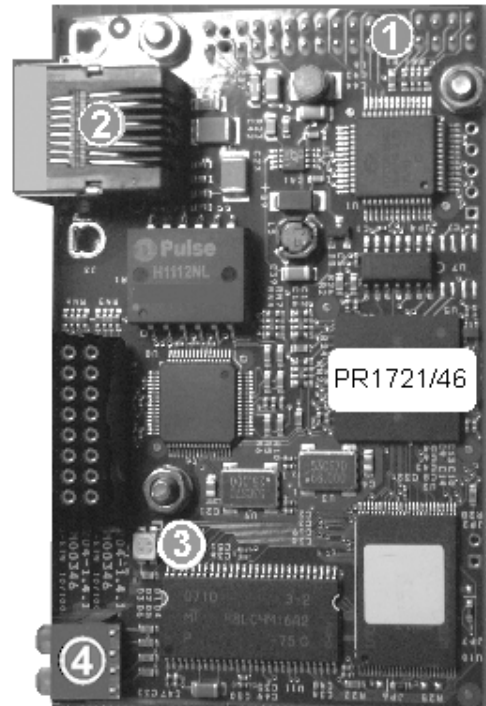

Technical data

Description	Data
Transfer rate	10 Mbit/s and 100 Mbit/s Auto-detection (100, FullDX)
Protocol	ProfiNet I/O
Connection mode	Network
Configuration	XML file "GSDML-Vx.xx-Sartorius-PR5230-xxxxxx.xml"
Potential isolation	Yes
Cable type	Twisted pairs, screened, e.g., patch cable CAT5 Autolink (straight or crossover)
Cable impedance	150 Ω
Cable length to HUB	Max. 115 m
Certificate	ProfiBus Nutzerorganisation e.V. for HMS Industrial Networks AB Certificate no.: Z10931

Note:

The IP address and subnet mask are set under  - [Fieldbus parameters] (refer also to Chapter [7.15.5](#) and [12.2](#))

The XML file is stored on the CD supplied with the device (fieldbus directory of the respective device). The current file is also available to download online:

<http://www.minebea-intec.com>

Note:**Fieldbus parameters**

Recommendation for a Siemens S7, for example

- ▶ Fieldbus slave setting:
- ▶ Use DHCP [on] as per the default settings and activate the master as a DHCP server (W [Allocate IP adr via IO controller]).

NOTICE**Slave – master device names**

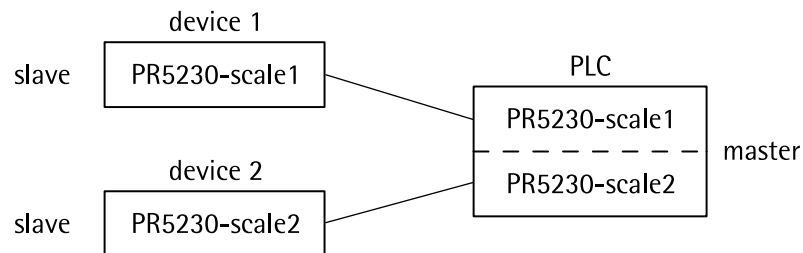

A unique device name must be assigned out of the master. This name is given highest priority when establishing a connection.

- ▶ When replacing devices or servicing, please note:
- ▶ As well as the IP address, the device name must correspond to that of the replacement device. Explicit assignment out of the master is required.

Example:

4.6.9.1 Status indicator

Requirements:

- The items are defined via  - [Display items] - [Fieldbus LEDs] ; see Chapter 7.15.7.
- PR 1721/46 is selected via  - [HW-Slots] - [Slot 2] .

Display:

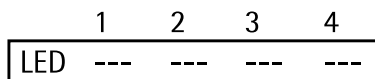

LEDs in device:

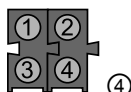

1	2	3	4
Constant ---: No link or no power	Constant ---: "Offline," no connection	Constant ---: No function	Constant ---: No power or not initialized.
Constant grn : Link detected.	Constant grn : Link detected; online and connected.		Constant grn : Initialized, no error.
Flashing 1 Hz grn : Send/receive data.	Flashing 1 Hz grn : "Online, not connected."		Flashing 1 Hz grn : Diagnostics data can be accessed.
			Flashing 2 Hz grn : Engineering tool for identification is active.
			Flashing 1 Hz red : Configuration error
			Flashing 3 Hz red : No station name, no IP address
			Flashing 4 Hz red : Internal error

Legend

---	off
red	red
grn	green

4.6.9.2 Connection

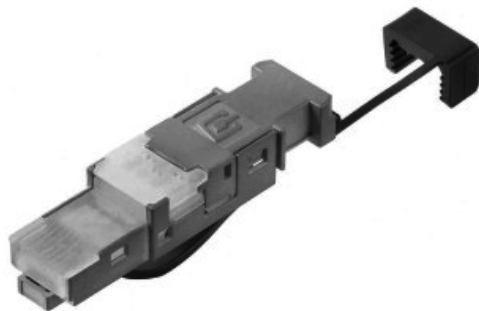

1. Guide the cable (e.g., patch cable CAT5) into the instrument through the metal sleeve of the cable gland, strip the insulation, and mount the supplied RJ-45 plug (see mounting information for connector).
2. Insert the RJ-45 plug into the RJ-45 socket of the fieldbus card.
3. Tighten the cable gland of the instrument.

4.6.10 EtherNet/IP interface

The EtherNet/IP interface card has the type designation PR 1721/47.

The fieldbus card is equipped with a standard RJ-45 socket ② for network connection.

It contains powerful UDP/IP connecting circuitry with transfer rates of 10 and 100 Mbit/s.

The card is inserted into "Slot 2" ① (see Chapter 4.6.1).

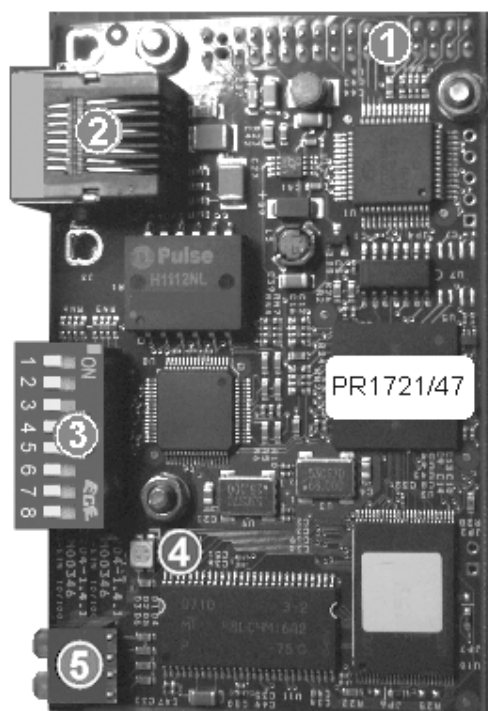

Technical data

Description	Data
Transfer rate	10 Mbit/s and 100 Mbit/s Auto-detection (100, FullDX)
Protocol	EtherNet IP

Description	Data
Connection mode	Network
Configuration	EDS file "sag_5230_ethernetip.eds"
Potential isolation	Yes
Cable type	Twisted pairs, screened, e.g., patch cable CAT5 Autolink (straight or crossover)
Cable impedance	150 Ω
Cable length to HUB	Max. 115 m
Certificate	EtherNet IP specification <ul style="list-style-type: none"> - ODVA file no. 10286 - Test date: 9/6/2005 - Vendor ID 90 - See also: www.odva.org - Industry-compatible CE, UL, and cUL

Note:

The IP address and subnet mask are set under  - [Fieldbus parameters] (refer also to Chapter [7.15.5](#) and [12.2](#))

The EDS file is stored on the CD supplied with the device (fieldbus directory of the respective device). The current file is also available to download online:

<http://www.minebea-intec.com>



4.6.10.1 Controls on fieldbus card**NOTICE**

The ③ DIL switch settings will not be used.

- ▶ Make sure that the switches 1..8 are set to position "OFF."

Settings are defined via  - [Fieldbus parameter].

4.6.10.2 status indicator**Requirements:**

- The items are defined via  - [Display items]- [Fieldbus LEDs]; see Chapter [7.15.7](#).
- PR 1721/46 is selected via  - [HW-Slots]- [Slot 2].

Display:

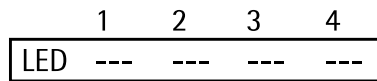

LEDs in device:

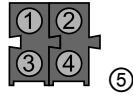

1	2	3	4
Constant ---: No connection	Constant ---: No power	Constant ---: No function	Constant ---: No power or no IP address
Constant grn : Link detected.	Constant grn : Controlled by scanner.		Constant grn : Online, link established.
	Flashing grn : Not configured, or scanner not active	Flashing grn : Packet is received or transmitted.	Flashing grn : Online, no link established.
	Constant red : Major fatal error		Constant red : Duplicate IP address, major error
	Flashing red : Minor recoverable error		Flashing red : Connection timeout
	Alternating red/grn : Self-test running.		Alternating red/grn : Self-test running.

Legend

---	off
red	red
grn	green

4.6.10.3 Connection

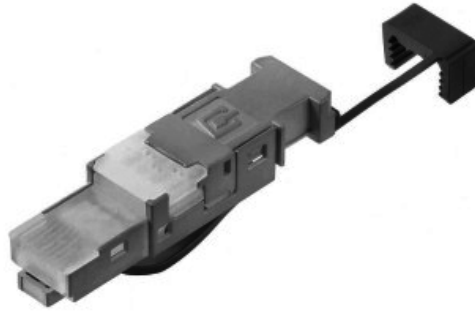

1. Guide the cable (e.g., patch cable CAT5) into the instrument through the metal sleeve of the cable gland, strip the insulation, and mount the supplied RJ-45 plug (see mounting information for connector).
2. Insert the RJ-45 plug into the RJ-45 socket of the fieldbus card.
3. Tighten the cable gland of the instrument.

4.6.11 Ethernet port for PR 5230/30

Note:

For the built-in Ethernet interface only.



4.6.12 Ethernet cable for PR 5230/31

Note:

For the built-in Ethernet interface only.



5 "Standard" application

5.1 Functions

5.1.1 General information

The "Standard" application supports the weighing functions of the device.
Filling is not possible.

5.1.2 Display functions

- Display of gross, net or tare weight
- Tare/reset tare
- Set gross to zero
- Print weight
- Display of weight values or remote display
- Functions via digital inputs and outputs
- Information interchange via serial I/O, fieldbus and network

6 "EasyFill" application

6.1 Functions

6.1.1 General information

The "EasyFill" application is used for the batching of single components.

The application allows for quick and reliable filling and emptying of vessels.

The dosing process can be started, stopped, interrupted and restarted via the VNC user interface, digital inputs, OPC/Modbus and field bus (except for CC link).

6.1.2 Display functions

- Display of gross, net or tare weight
- Tare/reset tare
- Set gross to zero
- Print weight
- Display of weight values or remote display
- Functions via digital inputs and outputs
- Information interchange via serial I/O, fieldbus and network

6.1.3 Filling mode

The "EasyFill" application supports the following filling modes:

- Net filling "B1"
- Net discharge "B4"

6.2 Application menu [Start]

Filling	
- Material ID	Material identification Selection: ID 1...10
- Material name	Material name Input: max. 18 alphanumeric characters
- Set point	Set point Input: weight; adopt unit from the calibration.
- Preset	Preset point for switching from coarse flow to fine flow. Input: weight; adopt unit from the calibration.
- Overshoot (OVS)	Material overshoot Input: Weight; adopt unit from the calibration.
- +/- tolerance	Tolerance above/below set point Input: tolerance values; adopt unit from the calibration.
- Calming time	Calming time Input: in ms
- Start	Start filling.
- Stop	Stop filling.
- Restart	Restart filling.
- Abort	Abort filling.

Configuration	
Configuration mode	Configure the mode
Dosing mode	Filling mode Selection: Net filling (B1), Net Discharge (B4)
Interaction mode	Interaction mode Selection: Remote proc. control, VNC, Front keys
Print	Print configuration.
Configuration digital I/Os	
Configuration digital inputs	Configure digital inputs
1...3: SPM address	Input: SPM address, see Chapter 13.4
%MX	
Print	Print configuration.
Configuration digital outputs	Configure digital outputs
1...3: SPM address	Input: SPM address, see Chapter 13.4
%MX	
Print	Print configuration.
Configuration material	
Material ID	Material identification Selection: ID 1...10
Material name	Material name Input: max. 18 alphanumeric characters
Set point	Set point Input: weight; adopt unit from the calibration.
Preset	Preset point for switching from coarse flow to fine flow. Input: weight; adopt unit from the calibration.
Overshoot (OVS)	Material overshoot Input: weight; adopt unit from the calibration.
+/- tolerance	Tolerance above/below set point Input: tolerance values; adopt unit from the calibration.
Calming time	Calming time Input: in ms
Default	Reset values to 0.
Print all	Print all ID entries.
Print	Print selected ID entry.
Configuration printing	
Number printouts	Number of printouts Input: 1...10
Sequence number	Sequence number, see Chapter 8.3.4 .
Use NLE	Use NLE Check the <input checked="" type="checkbox"/> box to activate printing with NiceLabelExpress.
Line 1...6	Line 1...6 Selection: see Chapter 8.3.4
Print	Print configuration.

7 Getting started

7.1 Power failure/Data backup/Restart

7.1.1 Power failure

If the grid power fails,

- all entered configuration and calibration parameters and
 - all the materials written on the built-in memory
- are saved.

The clock and the calendar continue to run.

7.1.2 Data backup

The calibration data and parameters as well as all configuration and interface data are stored in non-volatile (E)EPROM memory.

Unauthorized data changing can be prevented by an access code.

Additional write protection is provided for calibration data and parameters (see Chapter [7.1.3.1](#)).

7.1.3 Overwrite protection

7.1.3.1 CAL switch

The CAL switch protects the calibration data and parameters against unauthorized access.

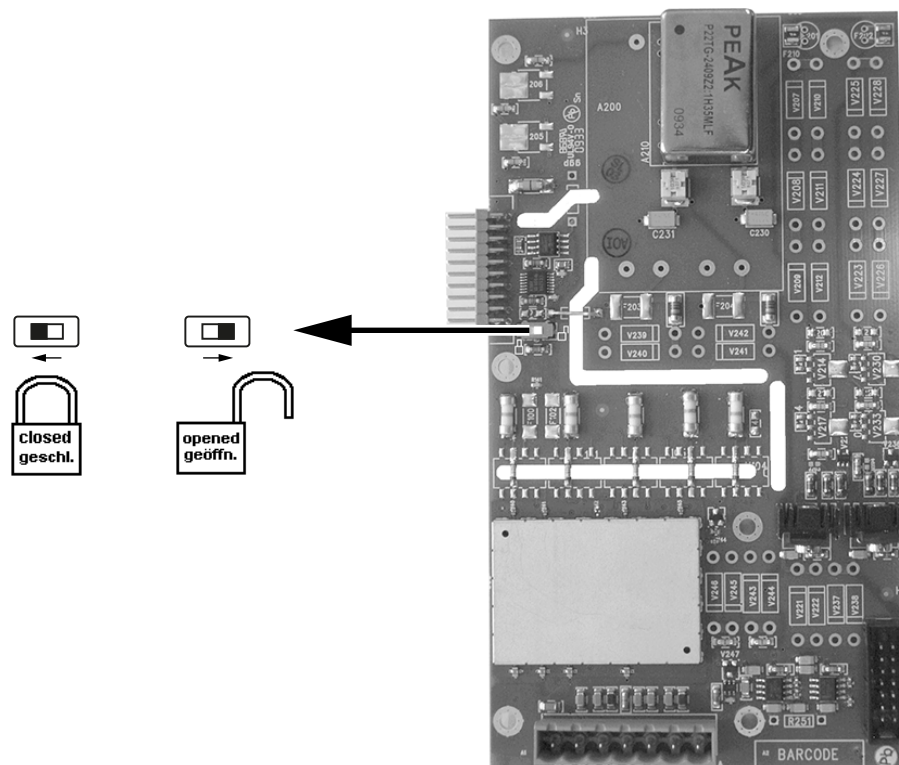



When the CAL switch is in "opened" position, the calibration data and parameters can be changed using the PC program or via the ProfiBus connection.

With the CAL switch in the "closed" position, the calibration data (e.g. dead load, SPAN) and parameters (measuring time, zero tracking etc.) cannot be changed.

Note:

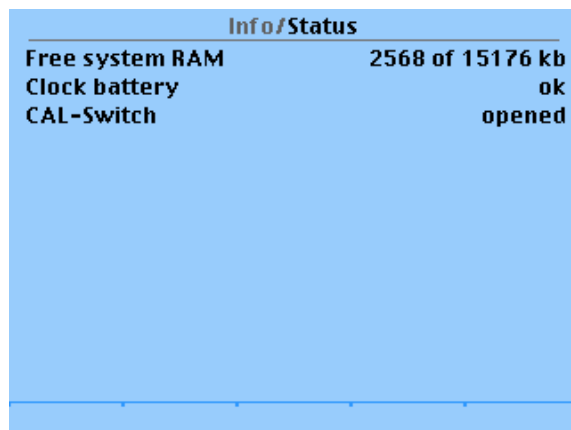
If the weighing electronics board has been changed after calibration or the device is not calibrated the weight value display will show "E:BadDev" if the CAL switch is closed.



The position of the CAL switch is shown with VNC/WEB browser under  – [Show status]:

[opened] = opened, no write protection.

[closed] = closed, write protection is active.

With the CAL switch in the 'closed' position, the weight is inversely shown in the display of the device.

7.1.3.2 Factory settings

Calibration data <default>	Calibration parameters <default>
Full Scale (FSD) (Max) <3000> <k-g>	Measurement time <160> ms
Scale interval <1>	Digital filter <off>
Dead load <0.000000> mV/V	Test mode <absolute>
SPAN <1.000000> mV/V	W&M <none>
	Standstill time <0.5> s
	Standstill range <1.00> d
	Zero range <50.00> d
	Zerotrack range <0.25> d
	Zerotrack step width <0.25> d
	Overload (range over Max.) <9> d
	Min <20> d

7.1.4 Restart

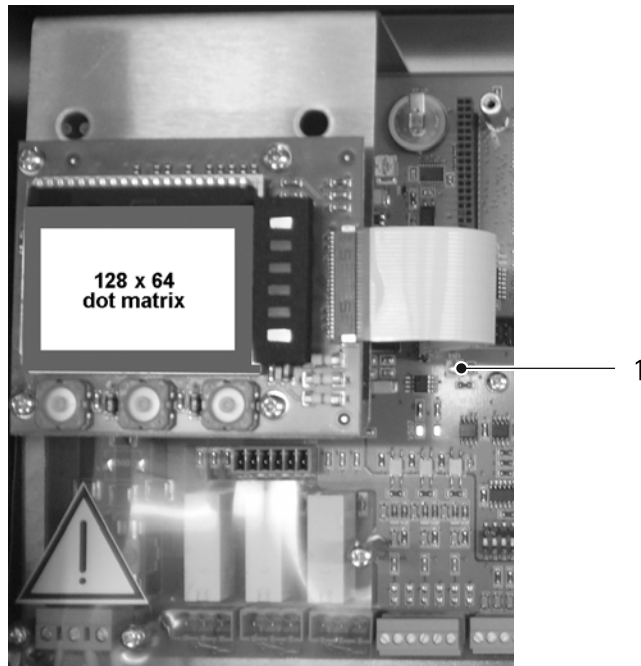

The instrument can be reset using a round-headed pin with a diameter of approx. 2.0 mm.

After pressing the Reset key (1) briefly (less than 1 sec.), the device is restarted.

Restarting has the following effects on the device:

- Current process steps are deleted.
- The device is reset to its factory settings.
- The network settings are not changed.

7.2 Switching on the device

The device can be set up as follows:

- Via a notebook/PC using the VNC software (included on the CD)
- Via a notebook/PC using an Internet browser

When the device is powered up, the following is shown on the display and/or notebook/PC:

Checking...	The device is booting up.
Booting...	
Restoring...	
PR 5230	<ul style="list-style-type: none"> - The instrument type is displayed, PR 5230 - BIOS version - Firmware version - Automatic display test - Weight display

E:NoSig	Error message: if no load cells are connected, see also Chapter 16.1 .
E:Sense	Error message: if no load cells are connected, see also Chapter 16.1 .
E:NoCom	Error message: if there is no communication with the xB-PI scale (see also Chapter 16.3).
E:HardE	Error message: unable to read weight values from the ADU (analog-digital converter); see also Chapter 16.1 .
E:NotRd	Error message: if no load cells or no scale is connected (see also Chapter 16.3).

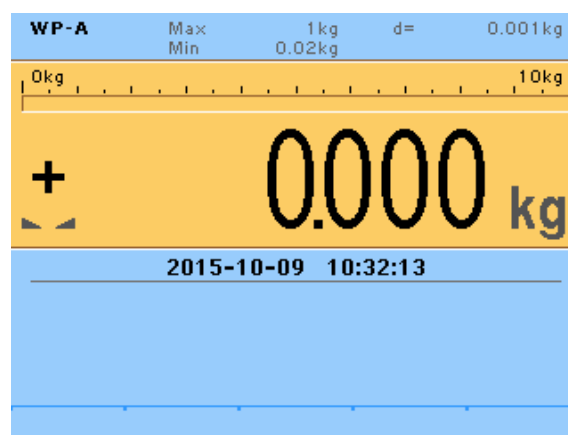

The weight display is shown.

Check the date and time after first turning on the device, see Chapter [7.15.2](#).

7.3 Switching off the device

The device is switched off/disconnected from power supply by pulling the plug.

7.4 Warm-up time

The device requires a warm-up time of 30 minutes before calibration.

7.5 Finding and connecting a device with a notebook/PC

If the device is connected to a notebook/PC via a point-to-point connection, an IP address is negotiated via function "AutoIP". This can take up to 2 minutes!

NOTICE

When the IT/DHCP network cable is temporarily connected between the notebook/PC and a device, the DHCP server is lost and the notebook/PC returns to the auto-IP address within approx. two minutes!

- ▶ Reason: The DHCP server/client relationship is checked cyclically at 2...3-minute intervals.

1. On the notebook/PC, set the LAN local and Internet Protocol properties to "Obtain an IP address automatically" depending on the operating system.

2. On the device, under  - [Network parameters] activate the "Use DHCP" parameter (factory/default settings).
 - ▷ The DHCP devices find each other because they fall into an "auto-IP address" in the range 169.254.0.1...169.254.255.254 with the associated auto-subnet mask 255.255.0.0 after a cyclical automatic DHCP server search run due to time overflow (2...3 minutes).

Example:

If the search time is exceeded (because there is "no server found"), the PR 5230 is assigned to an IP address automatically (e.g. 169.254.0.123). The same applies to the notebook or PC (e.g. 169.254.0.54).

These IP addresses are different on both sides:

- equal regarding the first 2 octets of the IP address (e.g. network ID 169.254.)
- different in the last 2 octets of the IP address (e.g. host ID 0.123.)

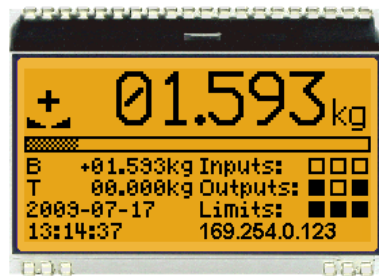

7.6 Finding and connecting the device automatically in the network

If the DHCP server is active in the network, the connected device (default setting under  - [Network parameters]: "Use DHCP" is activated.) is automatically assigned an IP address.

On the notebook/PC, the host names of the connected devices in the network are listed under [Network].

Double-click the host name to open the device page in the web browser. The IP address is displayed on the bottom right.

Note:

If the web browser supports the Java application, the device can be operated via [remote configuration (VNC).]

If the web browser does **not** support the Java application, the menu items will be inaccessible (grayed out).

7.7 Searching the device in the network with "IndicatorBrowser"

The IP address can be found out using the "IndicatorBrowser" application (supplied on CD-ROM) and via the "host name" of the device.

The "host name" is composed of the device name and the last 3 bytes of the MAC ID. A label with the complete MAC ID is located on the outside of the device.

MAC: 00:90:6C:6B:6A:5E 

IP: _____

Host name: PR5230-6B6A5E



For this, the program must be installed and started on a notebook/PC.

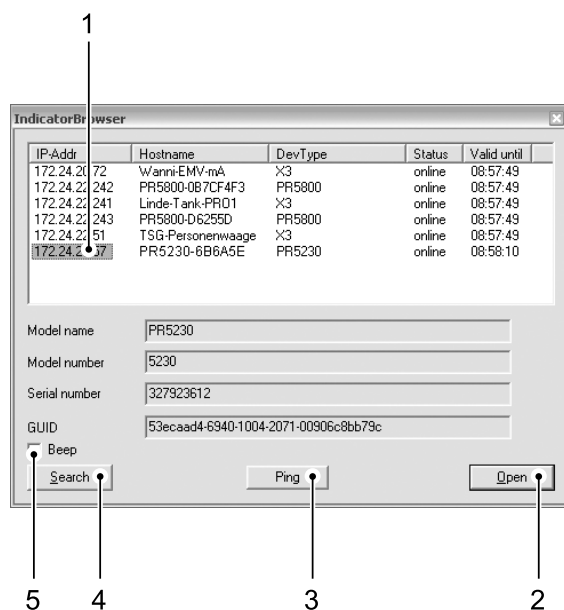

No. Description

- 1 The program searches within the current network ID, e.g. 169.254. and 172.24., on all available network adapters in the PC (several possible/recommended, e.g. LAN global/LAN local)
Result:
List of all connected devices with status: search??? – online - byebye – lost???
- 2 Click the button to open the "standard" Internet Browser, e.g. Microsoft Internet Explorer, directly with the marked IP-address.
- 3 Click the button to localize the associated device.
Short-term visual feedback from the device:
Regular running light in LED 1, 2, 3.
- 4 Click the button to re-start the network search run.
Waiting 2...3 minutes is essential!
- 5 Acoustic signal for each device that was detected as "online."

Note:

If the browser window remains empty after the minimum wait time, or if the expected device is not listed, the network ID of the local notebook/PC must be checked and changed, if necessary.

Only certain Minebea Intec devices are supported by the "indicator browser"!

7.8 Resetting the network address

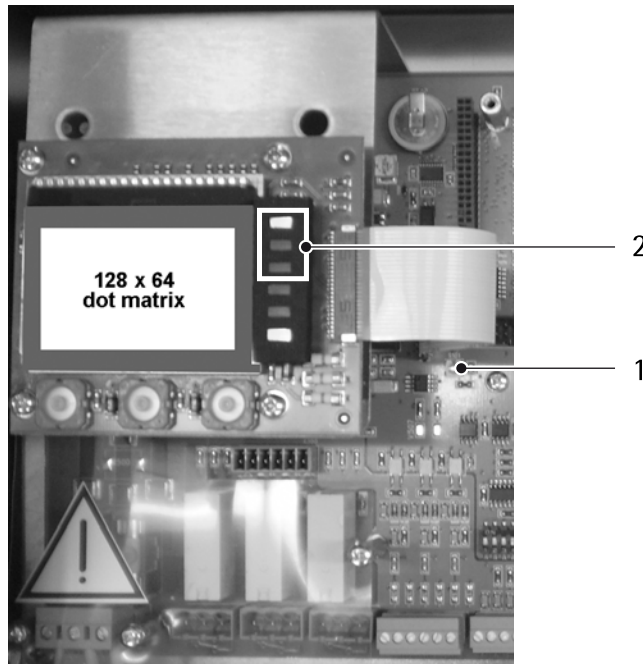

The device can be reset using a round-headed pin with a diameter of approx. 2.0 mm. Holding down the reset key (1) for a longer period [wait until the 3 upper LEDs (2) are all on] resets the network settings to default/factory settings.

This means

- "DHCP" is activated.
- "Hostname" is initialized to, e.g. PR 5230-6B6A5E (type MAC-ID).

Example of MAC ID: 00-90-6C-6B-6A-5E

This ensures that a valid address for identification of the device in the network can be assigned to the device from a server, see also Chapter [7.15.6](#).

Note:

The last 3 bytes of the MAC ID are displayed. A label with the complete MAC ID is located on the outside of the device.

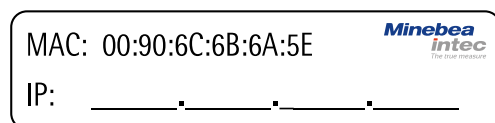

If the device is connected to an IT network (company network) with an DHCP server and was activated under  - [Network parameter] of the "Use DHCP" parameter (default/factory setting), it does not require further actions except for a 2...3-minute waiting time. Subsequently, a network connection is established automatically (device <-> workstation/PC).

7.9 Operation using VNC

VNC (on the enclosed CD-ROM) stands for "virtual network computing" and is a program for remote operation of computers.

The program distinguishes between the VNC server and VNC client (viewer). The server program is part of the device software, the client program (viewer) must be run on the notebook/PC in order to operate the device.

Note:

If the colors appear distorted, a better color format must be selected in the VNC viewer.

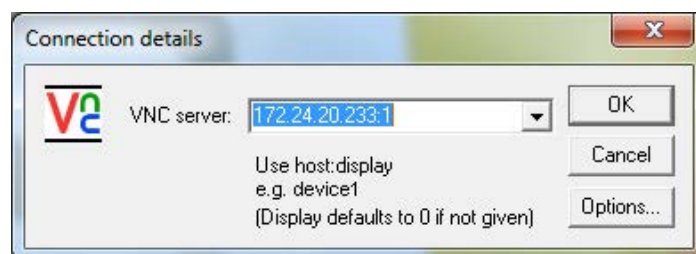

For direct operation using the VNC program, the IP address (extended by :1) must be specified when you run the program, e.g., 172.24.20.233:1.

Note:

In the device, the VNC access to certain notebooks/PCs in the network can be limited, see Chapter [7.15.6](#).

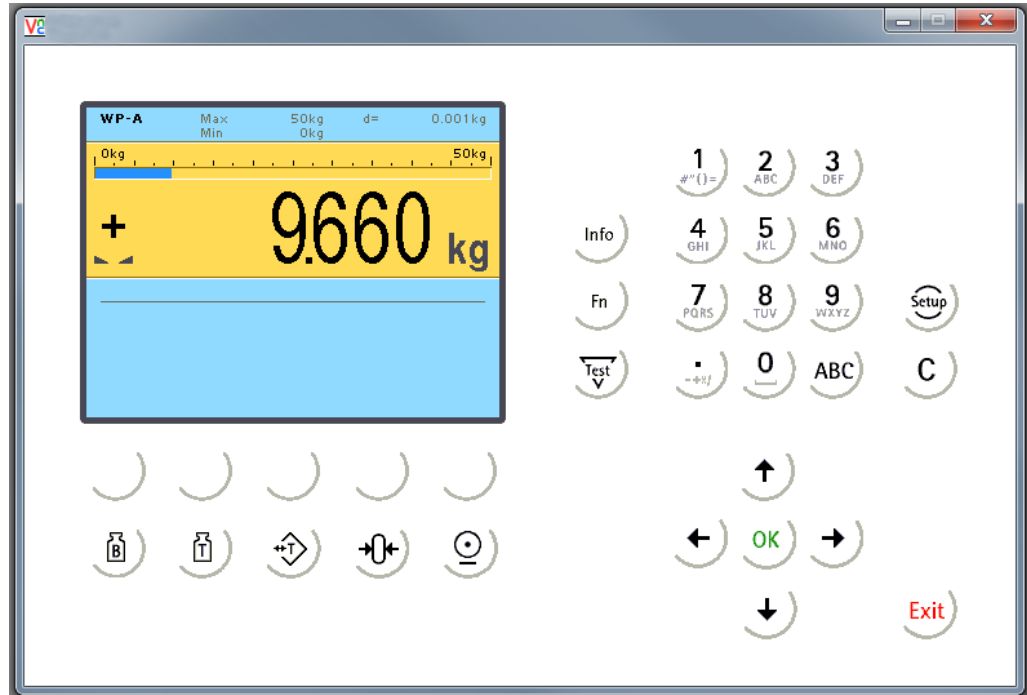

NOTICE

If the VNC viewer is terminated on the setup level (e.g. by closing the window or the back function in the web browser), the device reboots and the web menu is not accessible for several seconds.

- ▶ Before terminating the VNC viewer keep pressing the **Exit** key to quit the setup level.

7.10 Operation via a web browser

Instead of the VNC viewer, the web browser can also be used directly. The disadvantage is that an additional "Java" installation is required.

Note:

If the web browser supports the Java application, the device can be operated via [remote configuration (VNC).]

If the web browser does **not** support the Java application, the menu items will be inaccessible (grayed out).

In addition to VNC, this includes:

- easy operation for printing out the configuration
- easy operation for displaying and saving protocols
- easy operation for saving and loading configuration and calibration data

Example: 

Enter the IP address in the Internet browser and confirm.

The web menu is displayed.

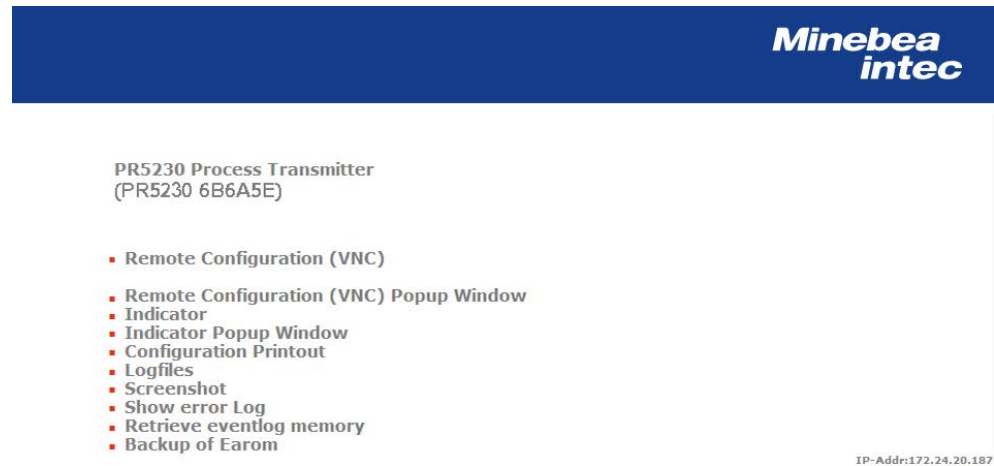

For description of the web menu see Chapter [9.2.1](#).

NOTICE

If the VNC viewer is closed on the setup level, the device reboots and the web menu is not accessible for several seconds.

- ▶ If the web menu and the device view are required, the [Remote Configuration (VNC) Pop-up Window] menu item must be selected in order for 2 windows to be opened with the VNC viewer always remaining open, even if individual menu items are selected in the web menu.

7.11 System setup

7.11.1 Serial ports parameter

<ul style="list-style-type: none"> — Printer <ul style="list-style-type: none"> — Param — Config — Remote display <ul style="list-style-type: none"> — Param — ModBus RTU <ul style="list-style-type: none"> — Param — SMA <ul style="list-style-type: none"> — Param — EW-Com <ul style="list-style-type: none"> — Param 	<p>Printer Selection: <none>, built-in RS232, Built-in RS485 Selection: Assigned to, protocol, Baudrate, Bits, Parity, Stopbits, Output mode See Menu [Printing parameter].</p> <p>Remote display Selection: <none>, built-in RS232, built-in RS-485 Selection: Assigned to, Baudrate, Bits, Parity, Stopbits, Mode</p> <p>Selection: <none>, built-in RS232, built-in RS-485 Selection: Assigned to, Baudrate, Bits, Parity, Stop bits, Slave-ID</p> <p>Selection: <none>, built-in RS232, built-in RS-485 Selection: Assigned to, Baudrate, Bits, Parity, Stopbits</p> <p>Selection: <none>, built-in RS-485</p>
---	--

<ul style="list-style-type: none"> ├─ xBPI-Port ├─ Param 	<p>Selection: Assigned to, Baudrate, Bits, Parity, Stopbits, Slave-ID</p> <p>Selection: <none>, built-in RS232, built-in RS-485</p> <p>Selection: Assigned to, Baudrate, Bits, Parity, Stopbits</p>
--	---

7.11.2 Date & time

<ul style="list-style-type: none"> ├─ Date ├─ Time 	<p>Date</p> <p>Input: yyyy, mm, dd</p> <p>Time</p> <p>Input: hh, mm, ss</p>
--	---

7.11.3 Operating parameters

<ul style="list-style-type: none"> ├─ Application ├─ Address ├─ PIN ├─ Use Alibi memory ├─ Sequence number ├─ SetTareKey ├─ SetZeroKey 	<p>Selection: Standard, EasyFill</p> <p>Device address, e.g. for printing</p> <p>Input: A...Z</p> <p>Entry code with which to protect the system control from unauthorized use.</p> <p>Input: 6 numerical characters</p> <p>Select which values should be written in the Alibi memory.</p> <p>Selection: <none>; Gross; Net; Gross, Net, Tare; Gross, Net; Gross, Tare</p> <p>Automatic counter for individual print jobs</p> <p>Tare key</p> <p>Selection: Tare&reset tare, tare&tare again, disabled</p> <p>Set zero key</p> <p>Select: only when not tared, reset tare on zeroset, disabled.</p>
--	---

7.11.4 Printing parameter

Note:

This menu item is only available if under -[Operating parameter]- [Application] "Standard" has been selected.

<ul style="list-style-type: none"> ├─ Printing mode ├─ Printing interval ├─ Printing interval unit 	<p>Printing mode</p> <p>Selection: Triggered (trigger one printout), Cyclic, Cyclic with enable</p> <p>Printing interval</p> <p>This menu item only appears if the [Cyclic] or [Cyclic with enable] printing mode has been selected.</p> <p>Input: 1...250</p> <p>Unit of the printing interval</p> <p>Selection: Seconds, Minutes, Hours, Meas. time</p>
--	---

	<ul style="list-style-type: none"> └─ Printlayout Item 1...6 	Print layout for line 1...6; see Chapter 7.15.4 .
7.11.5	Fieldbus parameter	
	<ul style="list-style-type: none"> └─ Fieldbus protocol 	Fieldbus protocol, display: Only if PR 1721/4x is installed in slot 2, see Chapter 7.15.5 .
7.11.6	Network parameter	
	<ul style="list-style-type: none"> └─ HW address 	MAC-ID, display: e.g.: 00:90:6C:31:1F:55
	<ul style="list-style-type: none"> └─ Hostname 	Unique device name, input: 2...24 alphanumerical characters
	<ul style="list-style-type: none"> └─ Use DHCP 	Check the <input checked="" type="checkbox"/> box to activate DHCP.
	<ul style="list-style-type: none"> └─ IP address 	IP address, display: network address assigned by the server
	<ul style="list-style-type: none"> └─ Subnet mask 	Subnet mask, display: Mask for valid IP address range
	<ul style="list-style-type: none"> └─ Default gateway 	Standard gateway, display: IP number for gateway
	<ul style="list-style-type: none"> └─ Remote access <ul style="list-style-type: none"> └─ VNC client 	Remote access to VNC client Access restriction, Input: authorized client for instrument operation
7.11.7	Weighing points	
	<ul style="list-style-type: none"> └─ Weighing point A <ul style="list-style-type: none"> └─ Calib └─ Setup └─ Config └─ Param └─ Assign 	<p>Selection: Internal A, xBPI-scale, Pendeo Load Cells</p> <p>Calibration, selected "Internal A:" New, Modify, Param, see Chapter 7.11.7.1.</p> <p>Setup, "xBPI-Scale" selected: Calibration, Configuration, Select, Show device info, see Chapter 7.11.7.2.</p> <p>Configuration, "xBPI-Scale" selected: Type, W&M, Tare timeout, Serial number, SBN Address, see Chapter 7.11.7.2.</p> <p>Configuration, "xBPI-Scale" selected: Assigned to, Baudrate, Bits, Parity, Stopbits, see Chapter 7.11.7.2</p> <p>Assign, "Pendeo Load Cells" selected: Search, View, Calib, LC name, Service, see Chapter 7.11.7.3.</p>
7.11.7.1	"Internal A" weighing point	
	<ul style="list-style-type: none"> └─ Calib <ul style="list-style-type: none"> └─ New <ul style="list-style-type: none"> └─ Max └─ Scale interval └─ Dead load at 	<p>Calibration of the weighing electronics</p> <p>Query window for new calibration: Reset Span and dead load</p> <p>Contin, Cancel</p> <p>Input of the maximum load: 0.00001...<3000>...999999 <kg>, t, lb, oz, g, mg</p> <p>Input of the scale interval: <1>, 2, 5, 10, 20, 50 <0.000000 mV/V> or [by load]</p>

		[by load]: 0.00001...999999 <kg>, t, lb, oz, g, mg
	Max at	<1.000000 mV/V> or [by load]
		[by load]: 0.00001...999999 <kg>, t, lb, oz, g, mg
	Calibrated at	Display only
	Sensitivity ($\mu\text{V/d}$)	Display only
	Test	Determine test value
	Exit calibration	Save or discard changes due to new calibration.
	Modify	May be used only for minor changes (e.g. changing the dead load, adapting mV/V values for dead load and/or Max). Otherwise, always use [New]!
	Param	Parameter settings
	Measuretime	Input of the measuring period: 5, 10, 20, 40, 80, 160, <320>, 640, 960, 1280, 1600 ms
	Digital filter	Selection of the digital filters: <off>, Bessel, aperiod., Butterw., Tcheby.
	External supply	Selection: below or equal 8 V ($\leq 8\text{ V}$), <above 8 V> ($> 8\text{ V}$)
	Fcut	Input of cut off frequency, only unless filter not "off", 0.1–80.0 Hz
	Test mode	Selection for display of the deviation from the test value: <Absolute>, relative
	W&M	Selection legal-for-trade mode: <none>, OIML (impossible when [Range mode] "Multi-interval" has been selected or Max has more than 3 decimals), NSC, NTEP
	Standstill time	Input of the standstill period: 0.01 s...<0.50 s>...2.0 s (The range depends on the measuring time.)
	Standstill range	Input of the standstill range: 0.00 d...<1.00 d>...10.00 d
	Tare timeout	Input of timeout when there is no standstill: 0.1 s...<2.5 s>...25 s
	Zeroset range	\pm Range of zero point when there is no standstill. Input: 0.00 d...<50.00 d>...10000.00 d
	Zerotrack indic. range	Input of the zerotrack indication range: 0.00 d...<0.25 d>...10000.00 d
	Zerotrack step	Input of the zerotrack step: 0.00 d...<0.25 d>...10.00 d
	Zerotrack time	Input of the zerotrack time: <0.0 s>...25 s
	Overload	Input of the weighing range above the maximum load (Max) without error message: 0...999999 d
	Minimum weight	Input of the minimum load: 0 d...<50 d>...999999 d
	Range mode	Range selection: <Single range>, Multiple range, Multi-interval
	Range limit 1	See also Chapters 7.12.15.1 and 7.12.15.2 .

<ul style="list-style-type: none"> — Range limit 2 	<p>Input of the limit 1: In weight, unit same as Max, transition from small to medium scale interval Only for [Multiple range] or [Multi-interval]!</p> <p>Input of the limit 2: In weight, unit same as Max, transition from small to medium scale interval Only for [Multiple range] or [Multi-interval]!</p>
<ul style="list-style-type: none"> — View 	<p>(when CAL-switch is closed)</p>
<ul style="list-style-type: none"> — Max — Scale interval — Dead load at — Max at — Calibrated at — Sensitivity (µV/d) 	<p>Display only</p> <p>Display only</p> <p>Display only</p> <p>Display only</p> <p>Display only</p> <p>Display only</p>
<ul style="list-style-type: none"> — Param 	<p>Items as for [Param] (display only)</p>

7.11.7.2 "xBPI scale" weighing point

<ul style="list-style-type: none"> — Setup 	<p>Setup of the xBPI scale</p>
<ul style="list-style-type: none"> — Calibration 	<p>Calibration of xBPI scale</p>
<ul style="list-style-type: none"> — Dead load 	<p>Dead load/preload</p>
<ul style="list-style-type: none"> — Set — Delete 	<p>Set dead load/preload: Accept, ResError, Abort</p> <p>Clear dead load/preload: Accept, ResError, Abort</p>
<ul style="list-style-type: none"> — Span 	
<ul style="list-style-type: none"> — Calibrate with user weight — Calibrate with auto weight — Adjust with default weight — Adjust with internal weight 	<p>Calibrate with user-defined weight.</p> <p>Calibrate with automatic weight detection.</p> <p>Calibrate with standard weight.</p> <p>Calibrate with internal weight.</p>
<ul style="list-style-type: none"> — Linearity 	<p>Setting linearity.</p>
<ul style="list-style-type: none"> — Default — User 	<p>Resetting the Device to the Factory Settings: Accept, ResError, Abort</p> <p>User defined settings: Accept, ResError, Abort</p>
<ul style="list-style-type: none"> — Configuration 	<p>Configuration of the scale</p>
<ul style="list-style-type: none"> — Weighing parameters 	<p>Weighing parameters</p>
<ul style="list-style-type: none"> — Ambient conditions — Application filter — Standstill range — Stability symb. delay — Tare parameter — Auto zero function — Adjustment function 	<p>Select environmental conditions: Very stable, stable, unstable, very unstable</p> <p>Select application filter: Final readout, Filling mode, Low filtering, w/o filtering</p> <p>Select standstill range: 0.25 igit, 0.5 digit, 1 digit, 2 digit, 4 digit, 8 digit</p> <p>Select Stability delay: no delay, short delay, average delay, long delay</p> <p>Select taring: at any time, not until stable</p> <p>Auto-Zero: auto zero on, auto zero off</p> <p>Adj. sequence: ext.adj.w.fact.wt., ext.adj.w.user.wt., ext.adj.w.pres.wt., internal adjust, ext.lin.w.fact.wt., ext.lin.w.user.wt., confirm preload, delete preload, adjust disabled</p>

				<ul style="list-style-type: none"> — Confirming adjust. Confirm calibration: manual, automatically — Zero range Zero point range: 1% of max load = 1%/Max. load, 2% of max load = 2%/Max. load, 5% of max load = 5%/Max. load, 10% of max load = 10%/Max. Load — Power-On zero range Initial zero point range: 2% of max load = 2%/Max. load, 5% of max load = 5%/Max. load, 10% of max load = 10%/Max. load, 20% of max load = 20%/Max. Load — Power-On tare/zero Tare/zero at power on: active, inactive, only for zeroing — Measure rate Measurement speed: normal output, fast output — Calibration check Calibration check: calibration prompt, off — External adjustment External adjustment: accessible, blocked — Application settings Setting up application <ul style="list-style-type: none"> — Application Tare Application Tare: accessible, blocked — Number of units Number of weight units: 1 weight unit, 2 weight units, 3 weight units — Weight unit 1...3 Chose weight unit 1...3: Gramm [g], Kilogram [kg], Carat [ct], Pound [lb], ounce [oz], Troy ounce [ozt], Tael Hongkong [tlh], Tael Singapore [tls], Tael Taiwan [tlt], Grain [GN], Pennyweight [dwt], Milligram [mg], Parts/pound [/lb], Tael china [tlc], Momme [mom], Karat [k], Tola [tol], Baht [bat], Mesghal [m], Ton [t] — Display accuracy 1...3 Chose display accuracy 13: all digits, reduced when moved, one level lower, two level lower, three level lower, 1%, 0.5%, 0.2%, 0.1%, 0.05%, 0.02%, 0.01%, Multi-interval, increased by 10 — Interface settings Configure the interfaces <ul style="list-style-type: none"> — Communication type Communication type: SBI protocol, xBPI protocol — Baudrate for SBI 150 baud, 300 baud, 600 baud, 1200 baud, 2400 baud, 4800 baud, 9600 baud, 19200 baud — Parity for SBI Select parity: Mark, Space, Odd, Even — Stop bits Selection: 1 stop bit, 2 stop bits — Handshake Selection: Software handshake, CTS with 2 chr.pau = CTS with 2 characters, CTS with 1 chr.pau = CTS with 1 character — Data output interval Select Data output interval: with each display, after 2 updates, after 5 updates, after 10 updates, after 20 updates, after 50 updates, after 100 updates — Parameter change parameter change: can be changed, cannot be changed — Select specification group <ul style="list-style-type: none"> — Specif. group 1...6 Select specification group of the scale (see operating manual of the relevant scale)
--	--	--	--	--

<ul style="list-style-type: none"> — Show device info <ul style="list-style-type: none"> — Set user — Set SBN — Config <ul style="list-style-type: none"> — Type — W&M — Tare timeout — Serial number — SBN Address — Param <ul style="list-style-type: none"> — Assigned to — Baudrate — Bits — Parity — Stop bits 	<p>Enter the user name of the connected device The xBPI address of the interface has to be <0 >, because there is no bus operation. Configuration of the xBPI scale xBPI-Scale Selection legal-for-trade mode: <none>, OIML, NSC, NTEP Timeout due to instability: 0.1 s...<2.0 s>...25 s <0>, if >0 the serial number will be checked (at legal-for trade scale) <0> no bus operation. parameter settings of the xBPI scale Assigned to: xBPI-Port 1 Select transmission speed: <9600>, 19200 8 odd (odd parity) Selection: <1>, 2</p>
---	--

7.11.7.3 "Pendeo® Truck/Process" weighing point

<ul style="list-style-type: none"> — Assign <ul style="list-style-type: none"> — Search <ul style="list-style-type: none"> — View <ul style="list-style-type: none"> — Info — Assign — Calib <ul style="list-style-type: none"> — New <ul style="list-style-type: none"> — Local gravity — Number of platforms — Number of vessel feet — Max — Scale interval — Dead load — CAL weight 	<p>Assignment of the Pendeo scale Type, number of load cells, serial number of each load cell and weighing point serial number (when it was already calculated) are displayed (when "Search" was executed). Search connected load cells. Search for a new network and reset the load cell data to the factory settings. Serial number and current weigh of connected load cells are displayed. The data for the selected Loading cell are displayed. load cells (serial number) are assigned to the installation site. Serial number and current weigh of connected load cells are displayed. Query window for new calibration: Corner correction will be reset Yes, No Enter the on-site gravitational acceleration (Standard: Hamburg 9.81379 m/s²) Only for Pendeo Truck: Only shown if the number of load cells is equal to 8. Only for Pendeo process: Enter the number. Enter maximum load: 0.000010...<3000>...9999998 <kg>, t, lb, g, mg, oz Enter verification interval (1 d): <1>, 2, 5, 10, 20, 50 displayed according to the decimal places at Max and the weight unit. dead load: Weight of the empty scale</p>
---	---

				Enter CAL weight: 0.000010...9999998 <kg>, t, lb, g, mg, oz
			Corner correction	Platform 1, platform 2 (only shown if the number of load cells is = 8). O.k., when realized.
			Modify	May be used only for minor changes (e.g. changing the dead load). Otherwise, always use [New]!
			Param	Parameter settings
			Ambient conditions	Select environmental conditions: Very stable, stable, unstable, very unstable
			W&M	Selection legal-for-trade mode: <none>, OIML, NSC, NTEP
			Unbal. Check deviat.	Unbalanced check deviation: The plausibility check is activated when the average deviation is >0%. Input: 0...100 %
			Standstill time	Input of the standstill period: 0.01 s...<0.50 s>...2.0 s (The range depends on the measuring time.)
			Standstill range	Input of the standstill range: 0.00 d...<1.00 d>...10.00 d (The range depends on the measuring time.)
			Tare timeout	Input of timeout when there is no standstill: 0.1 s...<2.5 s>...25 s
			Zeroset range	± Range of zero point when there is no standstill. Input: 0.00 d...<50.00 d>...10000.00 d
			Zerotrack indic. range	Input of the zerotrack indication range: 0.00 d...<0.25 d>...10000.00 d
			Zerotrack step	Input of the zerotrack step: 0.00 d...<0.25 d>...10.00 d
			Zerotrack time	Input zerotrack time: <0.0 s>...25 s
			Overload	Input of the weighing range above the maximum load (Max) without error message: 0...<9 d>...999999 d
			Min	Input of the minimum load: 0 d...<50 d>...999999 d
			Range mode	Range selection: <Single range>, Multiple range, Multi-interval See also Chapters 7.12.15.1 and 7.12.15.2 .
			Range limit 1	Input of the limit 1: In weight, unit same as Max, transition from small to medium verification interval
			Range limit 2	Only for [Multiple range] or [Multi-interval]! Input of the limit 2: In weight, unit same as Max, transition from small to medium verification interval
			LC name	Only for [Multiple range] or [Multi-interval]! Give each load cell a name.

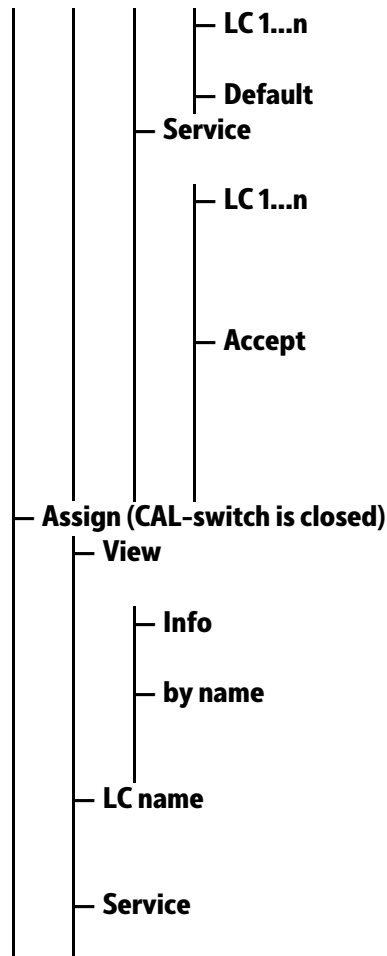

load cell 1...n, e.g.: PR6224-xx
 Input of max. 20 alphanumeric characters.
 Settings are reset to factory settings.
 Service function for load cells: Deactivate/ activate load cell.
 load cell 1...n
 Select the faulty load cell and reset to .
 Select the new (replaced) load cell and mark the checkbox .
 Accept:
 After deactivation the simulation for the deactivated load cell starts.
 Once the replaced load cell has been activated the search process starts.

Item number, serial number and current weight of connected load cells are displayed.
 The data for the selected Loading cell are displayed.
 Change the display from [ID] (LC 1...n + serial number) to [by name] of the load cells; only possible if a load cell name has been assigned.
 Change the display from [ID] (LC 1...n + serial number) to [by name] of the load cells; only possible if a load cell name has been assigned.
 The service window for the load cells is displayed. No change is possible!

7.11.8 Display items



Item 1 is a fixed setting: Indicator value.
 Selection: see Chapter [3.4.3.3](#)

7.11.9 Limit parameter

Note:

This menu item is only available if under -[Operating parameter]- [Application] "Standard" has been selected.

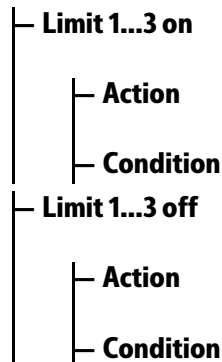

Enter 0 – Max (maximum load); take unit from calibration.
 Action, selection: no action, set marker 1...3, clr (clear) marker 1...3
 Condition, selection: see Chapter [7.15.8](#).
 Enter 0 – Max (maximum load); take unit from calibration.
 Action, selection: no action, set marker 1...3, clr (clear) marker 1...3
 Condition, selection: see Chapter [7.15.8](#).

7.11.10 Digital I/O parameters

Note:

This menu item is only available if under  -[Operating parameter]- [Application] "Standard" has been selected.

<ul style="list-style-type: none"> ├─ Output 1...3 ├─ Input 1...3 on <ul style="list-style-type: none"> ├─ Action ├─ Condition ├─ Input 1...3 off <ul style="list-style-type: none"> ├─ Action ├─ Condition 	<p>Configure outputs, selection: see Chapter 7.15.10.</p> <p>Configure inputs Action, selection: see Chapter 7.15.9.1. Condition, selection: see Chapter 7.15.9.2.</p> <p>Configure inputs Action, selection: see Chapter 7.15.9.1. Condition, selection: see Chapter 7.15.9.2.</p>
---	---

7.11.11 Analog output parameter

<ul style="list-style-type: none"> ├─ Analog mode ├─ Analog range ├─ Output on error ├─ Output if <0 ├─ Output if >Max ├─ Weight at 0/4 mA ├─ Weight at 20 mA 	<p>Analog output parameter: Gross D08 = gross, Net if tared D09 = Net if tared, Selected D11 = value on the display, Transparent D30 = Transparent, no output = analog output unused, see Chapter 7.15.12.</p> <p>Output range: 0...20 mA, <4...20 mA></p> <p>Output on error: 0 mA = set to 0 mA, <4 mA> = set to 4 mA, 20 mA = set to 20 mA, hold = last output value remains unchanged</p> <p>Output if <0: set 0 mA = 0 mA, set <4 mA> = 4 mA, set 20 mA = 20 mA, linear = goes below 4 mA down to the limit (with 4...20 mA)</p> <p>Output if >Max: set 0 mA = 0 mA, set 4 mA = 4 mA, set <20> mA = 20 mA, linear = exceeds 20 mA up to the limit</p> <p>Weight value for 0/4 mA output</p> <p>Weight value for 20 mA output</p>
---	---

7.12 Calibrating internal weighing point

7.12.1 General information

For legal-for-trade application select  - [Weighing point]- [Calib]- [Param], where the [W & M] must be set to "OIML" before calibration is started; see Chapter [7.12.15](#).

The calibration data are protected by the CAL switch (see Chapter [7.1.3.1](#)), which is sealed in the closed (write-protected) position for legal-for-trade applications.

7.12.2 Displaying calibration data

7.12.2.1 Overwrite protection via a CAL switch

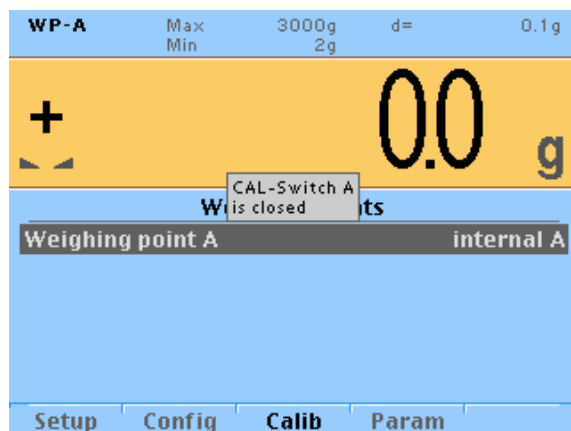

When the CAL switch is closed, a tool tip is displayed.

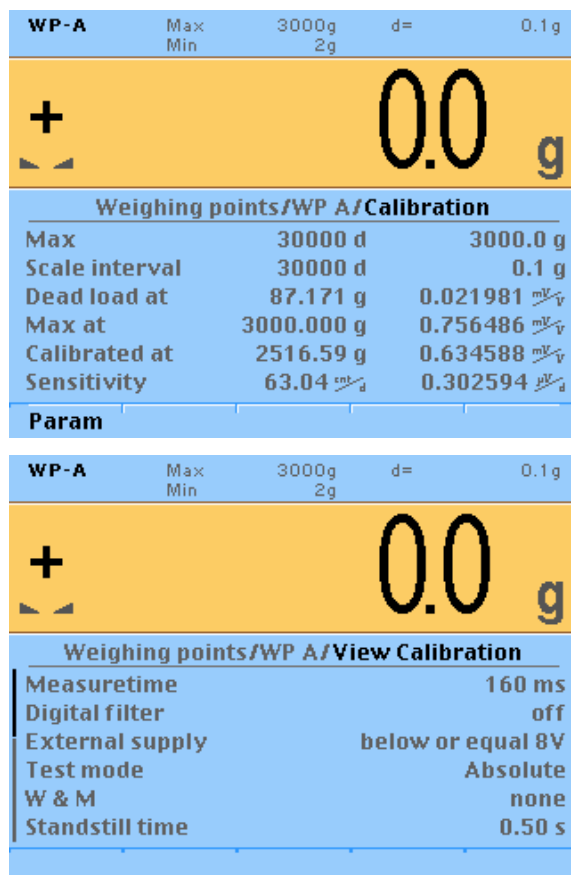

The Data under [Calib] and [Param] is displayed only.

The calibration data and parameters are displayed in the format entered/determined during calibration.

Note:

[Calibrated at]: CAL weight and corresponding mV/V

After input with mV/V, the full scale interval and the mV/V value entered are displayed.

7.12.2.2 Increased resolution (10-fold)

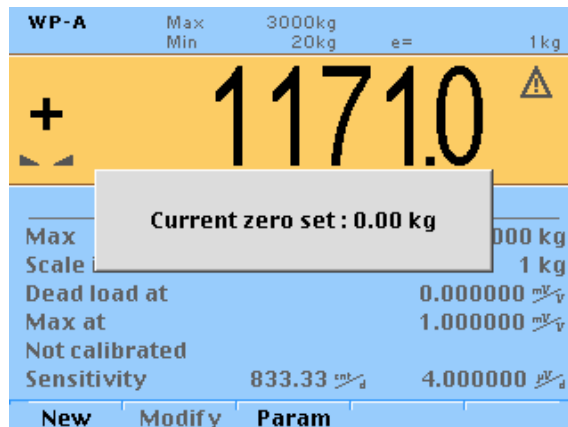

In the -[Weighing point]- [Calib] menu the weight is displayed with 10-fold resolution (also with the CAL switch closed) with .

After 5 seconds the display returns to normal resolution. Press  if you want to switch to normal resolution immediately.

7.12.3 Selecting the calibration mode

Note:

The [Modify] menu item is only used for small changes (e.g. changing the dead load/preload, changing the mV/V values for dead load/preload and/or Max, changing the scale interval). Otherwise select the [New] menu item.

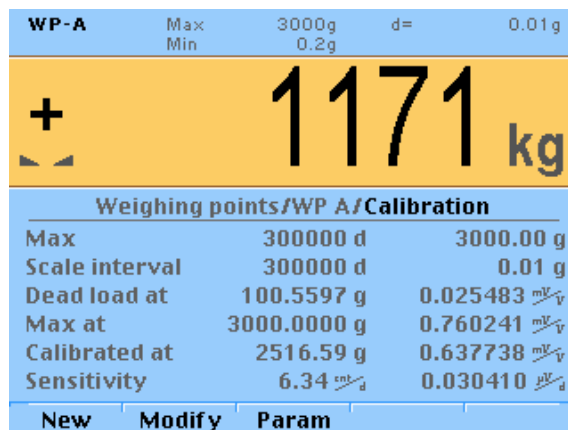

Under -[Weighing point]- [Calib] choose between [New] and [Modify].

7.12.3.1 Performing a new calibration

1. Select -[Weighing point]- [Calib] and confirm.

WP-A			
Max	3000g	d=	0.01g
Min	0.2g		
+ 1171 kg			
Weighing points/WP A/Calibration			
Max	300000 d		3000.00 g
Scale interval	300000 d		0.01 g
Dead load at	100.5597 g		0.025483 $\frac{mV}{V}$
Max at	3000.0000 g		0.760241 $\frac{mV}{V}$
Calibrated at	2516.59 g		0.637738 $\frac{mV}{V}$
Sensitivity	6.34 $\frac{mV}{g}$		0.030410 $\frac{mV}{g}$
New Modify Param			

2. Press the [New] softkey.
 - ▷ A prompt window opens.

WP-A			
Max	3000kg	d=	1 kg
Min	20kg		
+ 1171 kg			
Weight	?		ation
Max			000 kg
Scale i			1 kg
Dead l	Span and dead load will be reset.		00 $\frac{mV}{V}$
Max a			00 $\frac{mV}{V}$
Not ca			00 $\frac{mV}{V}$
Sensit			00 $\frac{mV}{g}$
Continue Cancel			
New			

3. By pressing [Continue] the data are reset to default first (default) before performing calibration. Press [Cancel] to cancel selection.
4. Determining the maximum load [Max], see Chapter [7.12.4](#).
5. Determining the scale interval [Scale interval], see Chapter [7.12.5](#).
6. Determining the dead load [Deadload at], see Chapter [7.12.6](#).
7. Calibrating with load [Max at], see Chapter [7.12.7](#).
8. Calibrating with mV/V [Max at], see Chapter [7.12.8](#).
9. Calibrating with load cell data (smart calibration) [Max at], see Chapter [7.12.8.1](#).
10. Carrying out linearization, see Chapter [7.12.11](#).

7.12.3.2 Modifying a calibration

Note:

[Modify] may be used only for minor changes (e.g. changing the dead load, adapting mV/V values for dead load and/or Max). Otherwise, always use [New]!

Example:

Resetting the Dead Load

1. Select -[Weighing point]- [Calib] and confirm.

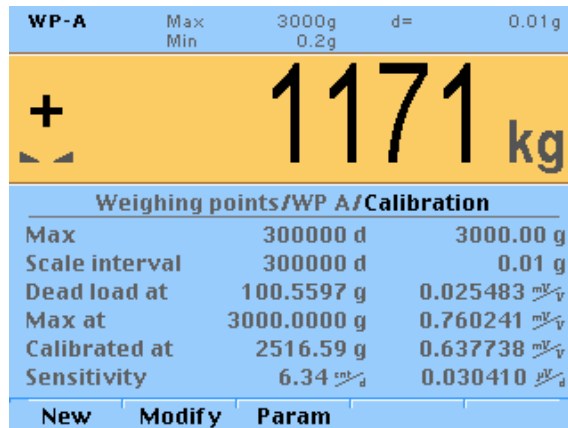

2. Press the [Modify] softkey.

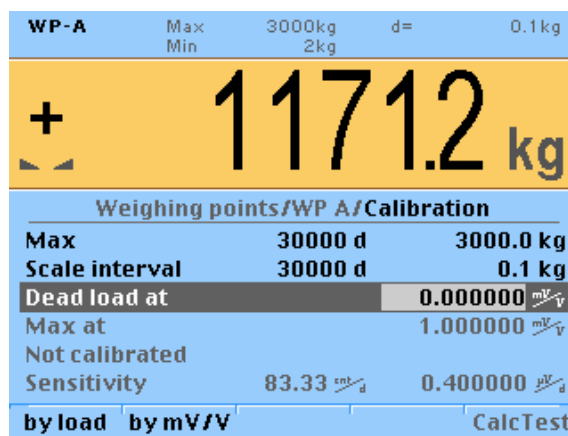

3. Choose the [Deadload at] menu item.
4. Either press the [by mV/V] softkey to enter the value again or clear the scale/hopper and press the [by load] softkey to reset the dead load.
5. Press **Exit** to exit the calibration.
 - ▷ A prompt window opens.

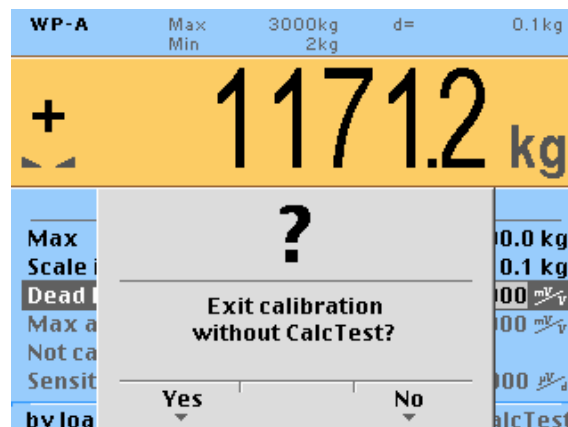

6. Press the [Yes] softkey to close the menu without calculation of the test value.
7. Press **Exit** to exit the calibration for good.
 - ▷ A prompt window opens.

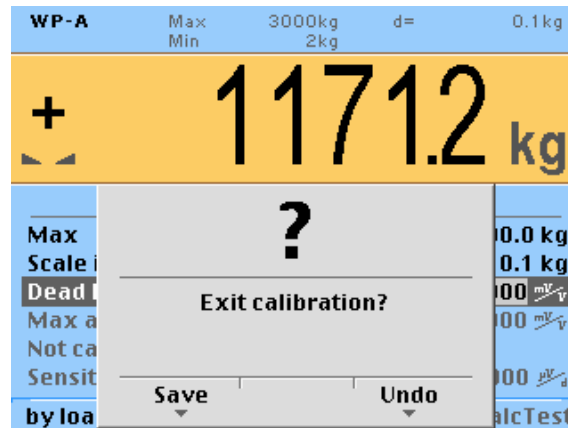

8. Press the [Save] softkey to save changes in calibration data.

7.12.4 Setting maximum load

The maximum load (Max) determines the maximum weight without dead load of the weight to be measured and the displayed number of digits behind the decimal point. Normally, Max is less than the load cell capacity (maximum capacity x number of load cells).

Permissible values for the maximum load are:

Max weight value from 0.00010 to 999999 in t, kg, g, mg, lb or oz.

Maximum weight value must be an integer multiple of the scale interval (1 d). It may have up to 6 digits and is entered as a numeric value with or without a decimal point.

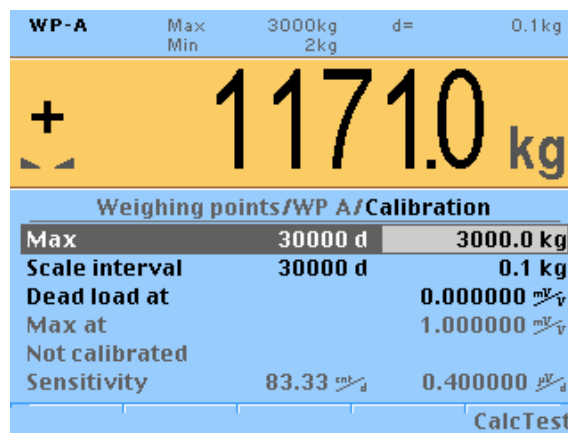

1. Enter the [Max] load with decimal places (in this example: 3000.0).
2. Press ABC to select the weight unit.
3. Confirm entries with OK or \downarrow .
 - ▷ The verification is displayed by "Setting Max..."

Note:

Error messages, calibration see Chapter [16.5](#).

7.12.5 Determining the scale interval

The scale interval (d) is the difference between two successive display values.

Example:

Max = 6000 kg

Scale interval (1 d) = 2 kg

Calculation for scale interval for Max (automatic):

$d = \text{Max} / \text{scale interval (1 d)}$

$d = 6000 \text{ kg} / 2 \text{ kg}$

$d = 3000$

Procedure:

The weight unit is taken from [Max]. The number of digits behind the decimal point is also automatically determined when [Max] is entered.

WP-A			
Max	3000kg	d=	0.1kg
Min	2kg		
+ 1171.2 kg			
Weighing points/WP A/Calibration			
Max	30000 d		3000.0 kg
Scale interval	30000 d	↔	0.1 kg
Dead load at			0.000000 $\frac{mV}{V}$
Max at			1.000000 $\frac{mV}{V}$
Not calibrated			
Sensitivity	83.33 $\frac{mV}{d}$		0.400000 $\frac{\mu V}{d}$
CalcTest			

1. Select [Scale interval] and confirm by pressing OK or \rightarrow .
 ▷ A selection window opens.
2. Select the scale interval (1 d) and confirm with OK .
 ▷ The scale interval (d) is then calculated, based on the Max weight value.
 The verification is displayed by "Setting Scale interval...".

Note:

Error messages, calibration see Chapter [16.5](#).

7.12.6 Determining the dead load

Note:

If a linearization was carried out (see Chapter 7.12.11), the following note appears on the display after the [Dead load at] line is selected:

Cannot be changed here while linearization is active.

Changes cannot be made while linearization is switched on.

Only deleting of the linearization points deactivates the linearization mode!

WP-A	Max	3000kg	d=	0.1 kg
	Min	2kg		
+ 1171.2 kg				
Weighing points/WP A/Calibration				
Max	30000 d	3000.0 kg		
Scale interval	30000 d	0.1 kg		
Dead load at		0.000000 $\frac{mV}{V}$		
Max at		1.000000 $\frac{mV}{V}$		
Not calibrated				
Sensitivity	83.33 $\frac{mV}{d}$	0.400000 $\frac{\mu V}{d}$		
by load	by mV/V			CalcTest

To use the empty scale/hopper as dead load (normal case):

1. Clear the scale/hopper.
2. Press the [by load] softkey.
3. Confirm entries with OK or \downarrow .
 - ▷ The verification is displayed by "Setting dead load...".

Note:

If the mV/V value of the dead load was calculated, or if it is known from the previous calibration, the value can be overwritten by pressing [by mV/V].

Error messages, calibration see Chapter 16.5.

7.12.7 Calibrating with weight

Note:

If a linearization was carried out (see Chapter 7.12.11), after selection of the line [Max at] the following tip is displayed:

Cannot be changed here while linearization is active.

Changes cannot be made while linearization is switched on.

Only deleting of the linearization points deactivates the linearization mode!

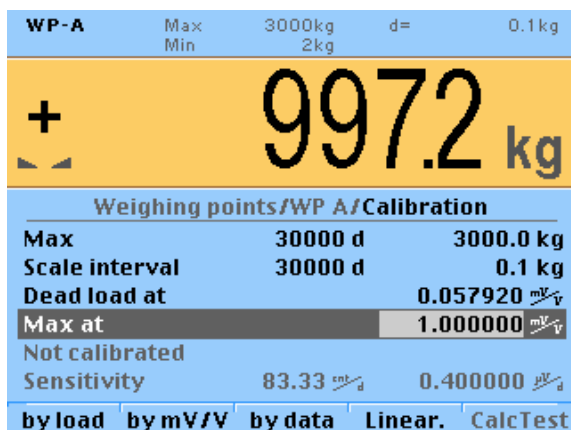

1. Press the [by load] softkey.

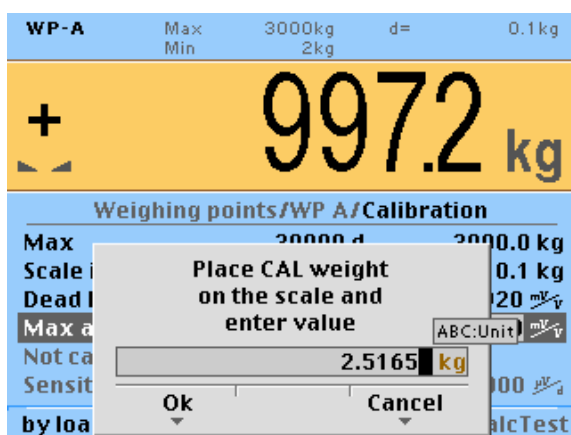

2. Place the CAL weight on the scale.
3. Enter the weight of the CAL weight.
4. Confirm the entries.
5. Press ABC to select the weight unit.

The weight unit for the CAL weight may differ from the unit in the device. Conversion is automatic.

6. Confirm entries with OK or \downarrow .
 - ▷ The verification is displayed by "Setting Span by load...".

Weight value, weight unit and measuring signal in mV/V corresponding to this value are displayed in the line [Calibrated at].

Note:

Error messages, calibration see Chapter [16.5](#).

7.12.8 Calibrating with mV/V

The scale can be calibrated without weights. During input of the load cell mV/V value, the acceleration of gravity at the place of installation can be taken into account.

The PR- load cell data is based on the acceleration of gravity in Hamburg, Germany:

9.81379 m/s².

WP-A		Max	3000kg	d=	0.1 kg
		Min	2kg		
		+ 997.2 kg			
Weighing points/WP A/Calibration					
Max	30000 d	3000.0 kg			
Scale interval	30000 d	0.1 kg			
Dead load at		0.057920 mV/V			
Max at		1.000000 mV/V			
Not calibrated					
Sensitivity	83.33 cm/d	0.400000 μV/d			
by load		by mV/V		by data	
		Linear.		CalcTest	

1. Calculating SPAN value for Max and, if necessary, for the dead see Chapter [7.12.8.1](#).
2. Press the [by mV/V] softkey.

WP-A		Max	3000kg	d=	0.1 kg
		Min	2kg		
		+ 997.2 kg			
Weighing points/WP A/Calibration					
Max	30000 d	3000.0 kg			
Scale interval	30000 d	0.1 kg			
Dead load at		0.057920 mV/V			
Max at		1.000000 mV/V			
Not calibrated					
Sensitivity	83.33 cm/d	0.400000 μV/d			
by load		by mV/V		by data	
		Linear.		CalcTest	

Enter input voltage
for SPAN

1.000000 mV/V

Ok Cancel

3. Entering the SPAN value for Max and, if necessary, for the subsequent correction of dead load (see Chapter [7.12.10](#)).
4. Confirm the entries.
 - ▷ The verification is displayed by "Setting Span mV/V...".

Weight value, weight unit and measuring signal in mV/V corresponding to this value are displayed in the line [Calibrated at].

Note:

Error messages, calibration see Chapter [16.5](#).

7.12.8.1 Calculating SPAN value

Calculating SPAN

SPAN indicates the equivalent input voltage in mV/V related to the maximum capacity (Max) of the scale. It is calculated as follows:

$\text{SPAN [mV/V]} = \text{maximum capacity} \times \text{load cell sensitivity } C_n \text{ [mV/V]} / \text{load cell capacity (maximum capacity } E_{\text{max}} \times \text{number of load cells)}$

load cell sensitivity $C_n = \text{rated output } C_n$ (see technical data for the load cell)

Calculate dead load

The input voltage in mV/V equivalent to the dead load can be calculated by using the dead load rather than the maximum capacity in the formula specified above.

Normally, calculation of the dead load (scale without load or empty vessel) is not necessary.

Subsequent dead load correction (see Chapter [7.12.10](#)) can be used for later re-determination of the dead load, when the scale or vessel is empty.

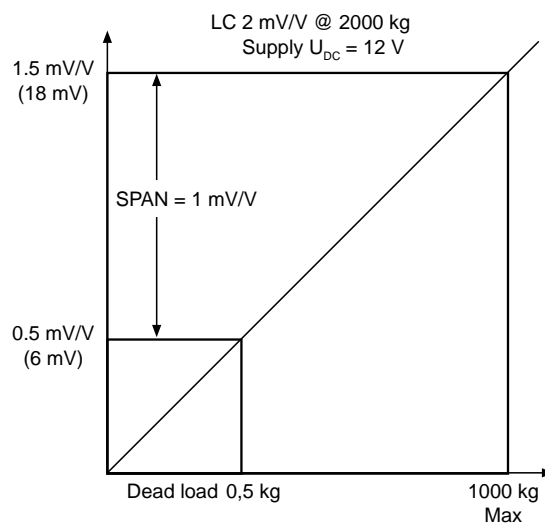

Example

- 1 load cell with rated output $C_n = 2 \text{ mV/V}$
- At maximum capacity 2000 kg
- Maximum capacity 1000 kg
- Dead load 500 kg
- Load cell supply voltage $U_{DC} = 12 \text{ V}$

7.12.9 Calibrating with load cell data (smart calibration)

If the scale is not used in legal metrology, calibration without weights can be performed. The easiest method is the one using load cell data without calculation.

WP-A	Max Min	3000kg 2kg	d=	0.1 kg
+ 997.2 kg				
Weighing points/WP A/Calibration				
Max	30000 d	3000.0 kg		
Scale interval	30000 d	0.1 kg		
Dead load at		0.057920 $\frac{mV}{V}$		
Max at		1.000000 $\frac{mV}{V}$		
Not calibrated				
Sensitivity	83.33 $\frac{mV}{V}$	0.400000 $\frac{mV}{V}$		
by load by mV/V by data Linear. CalcTest				

1. Press the [by data] softkey.

WP-A	Max Min	3000kg 2kg	d=	0.1 kg
+ 1171.3 kg				
... /WP A/Calibration/load cell configuration				
Number of loadcells		4		
max. capacity of load cell		3000 kg		
Gravity		9.81379 m/s^2		
Hysteresis error		not specified		
Certified data		all LC same		
LC output at max. capacity		1.000000 $\frac{mV}{V}$		
Enter Calc				

[Number of load cells]

Number of load cells connected in parallel

Input: 1, 2...<4>...9, 10

[max. capacity of load cell]

Maximum capacity E_{max} of a load cell (not the total maximum capacity of the scale!)

Input: For the value refer to the technical data of the load cell.

[Gravity]

Gravity at place of installation

Default is the value for Hamburg, Germany: 9.81379 m/s^2 .

[Hysteresis error]

Hysteresis error

When switching from [not specified] to [specified] values for [Correction A/B] must be entered. For this data refer to the load cell certificate.

[Certified data], [LC output at max. capacity], [LC output impedance]

LC = load cell

When [all LC same] is set, only one value for [LC output at max. capacity] and [LC output impedance] are required.

For [each LC specific] press the [Enter] softkey to enter individual data for each load cell.

2. Press the [Calc] softkey to start the calculation.
3. Confirm the calculation by pressing the [Ok] softkey to save the calculated mV/V value to the calibration data.

7.12.10 Subsequent dead load correction

If the hopper/platform weight changes by an amount that is higher than the zero-setting range; e.g. due to dead load reduction, dead load increase, or mechanical changes, the functions for automatic zero tracking and manual zero setting no longer work.

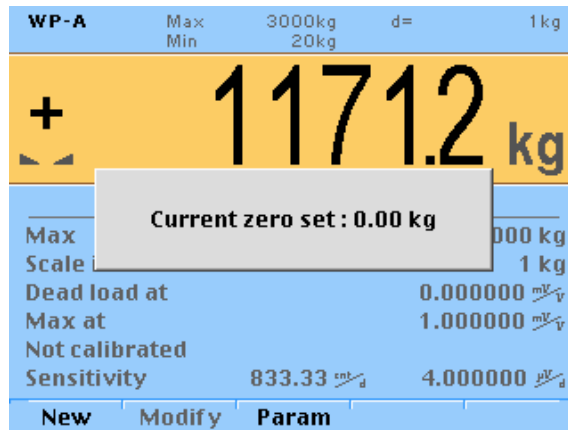

To view the range which is already utilized by zero tracking or zero setting, in [Calibration] press the  key; this also activates 10-fold increased resolution of the weight value.

Note:

The scale must not be loaded!

If the full zero-setting range is already being utilized, you can still correct the dead load (overwrite protection must be deactivated, see Chapter [7.1.3.1](#)) without affecting other calibration data/parameters. To do this select -[Weighing points]- [Calib]- [Modify] and determine the dead load with [Dead load at] using the [by load] option (see Chapter [7.12.6](#)).

Note:

If a linearization was carried out (see Chapter 7.12.11), the following note appears on the display after the [Dead load at] line is selected:

Cannot be changed here while linearization is active.

Changes cannot be made while linearization is switched on.

Only deleting of the linearization points deactivates the linearization mode!

7.12.11 Linearization

The measurement range for a straight can be optimized by setting the linearization points.

Requirements:

Calibration of Max and dead load was done.

Procedure:

WP-A	Max Min	3000kg 2kg	d=	0.1 kg
+ 997.2 kg				
Weighing points/WP A/Calibration				
Max		3000 d		3000.0 kg
Scale interval		3000 d		0.1 kg
Dead load at				0.057920 $\frac{mV}{V}$
Max at				1.000000 $\frac{mV}{V}$
Not calibrated				
Sensitivity		83.33 $\frac{mV}{d}$		0.400000 $\frac{\mu V}{d}$
by load by mV/V by data Linear. CalcTest				

1. Press the [Linear.] softkey.
 - ▷ The menu linearization is shown.

WP-A	Max Min	3000kg 2kg	d=	0.1 kg
- 0.0 kg				
/WP A/Calibration/Linearisation				
Calibrated with $\frac{mV}{V}$				1.000000 $\frac{mV}{V}$
Add by mV/V by load				

2. Press the [Add] softkey to set a linearization point.
 - ▷ The input window opens.

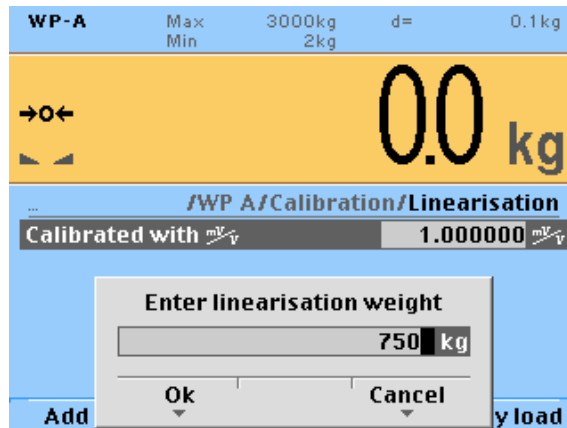

3. Enter the desired value using the keyboard.
4. Press the [Ok] softkey.
5. Repeat these steps to set up to three linearization points in succession.
 - ▷ The window shows the set linearization points.

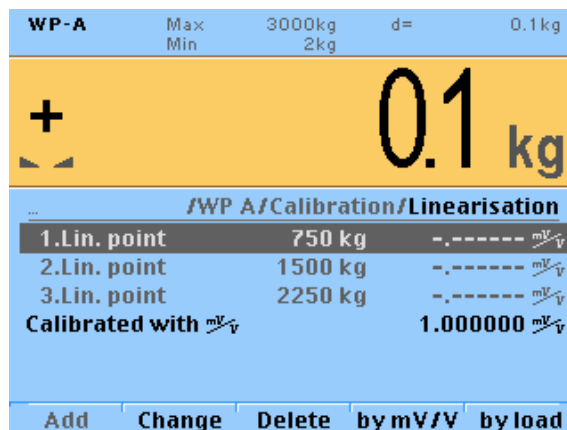

By pressing [by mV/V] the value can be entered directly.

By pressing [Change] the selected linearization point can be changed.

By pressing [Delete] the selected linearization point can be deleted.

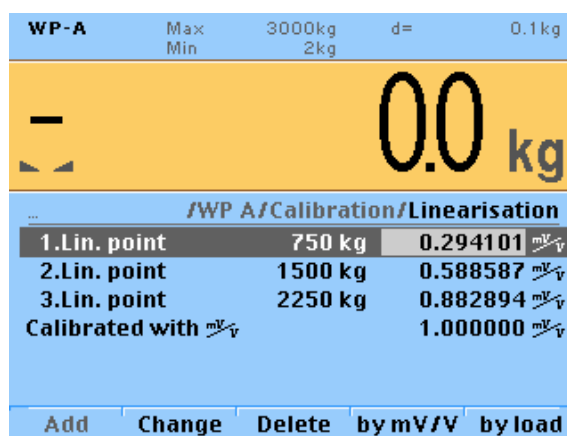

6. Select a linearization point, place the corresponding weight on the scale, and press the [by load] softkey.
 - ▷ The value corresponding to the weight is automatically entered in mV/V.

WP-A		Max	3000kg	d=	0.1 kg
		Min	2kg		
→0←		0.0 kg			
... /WP A/Calibration/Linearisation					
1.Lin. point	750 kg	0.294101	mV/V		
2.Lin. point	1500 kg	0.588587	mV/V		
3.Lin. point	2250 kg	0.882894	mV/V		
Calibrated with	mV/V	1.000000	mV/V		
Add		Change	Delete	by mV/V	by load

7. Repeat these steps to automatically enter the corresponding values for the weights of all set linearization points in mV/V.
8. Press  to switch to the previous window.



WP-A		Max	3000kg	d=	0.1 kg
		Min	2kg		
→0←		0.0 kg			
Weighing points/WP A/Calibration					
Max	3000 d	3000.0 kg			
Scale interv	Can not be changed here while linearisation is active	0.1 kg			
Dead load at		0.390422	mV/V		
Max at	3000.000 kg	1.000000	mV/V		
Calibrated with	mV/V	1.000000	mV/V		
Sensitivity	83.33 $\frac{mV}{d}$	0.400000	$\frac{\mu V}{d}$		
by load		by mV/V	by data	Linear.	CalcTest

- ▷ A message is displayed, indicating that the value for Max cannot be changed as long as linearization is active.

7.12.12 Calculating the test value

The calculation of the test value is called by pressing the [CalcTest] softkey.

The maximum load (Max) is displayed with the ID TST without a weight unit. The value determined during calibration by pressing the [CalcTest] softkey after starting the test is displayed.

Depending on the settings under  - [Weighing point] - [Calib] - [Param] - [Test mode] the following is displayed by calling the Test with the  key later on:

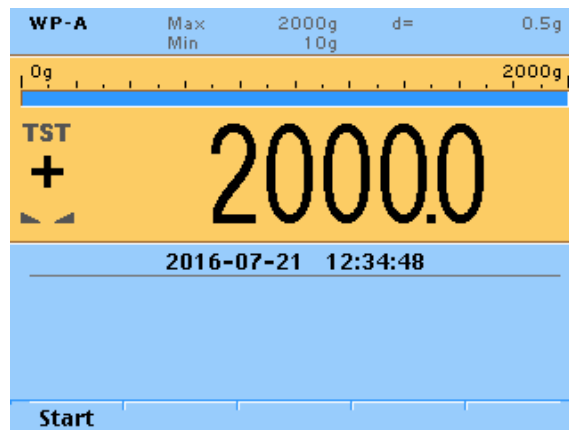

- with [Absolute] the maximum load
- with [Relative] the deviation from the test value

7.12.13 Saving the calibration

Quit calibration by pressing the  softkey.

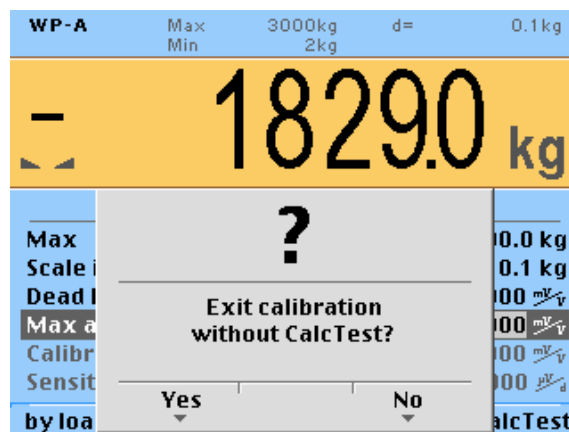

You are prompted to confirm whether calibration should be closed without determining the test value.

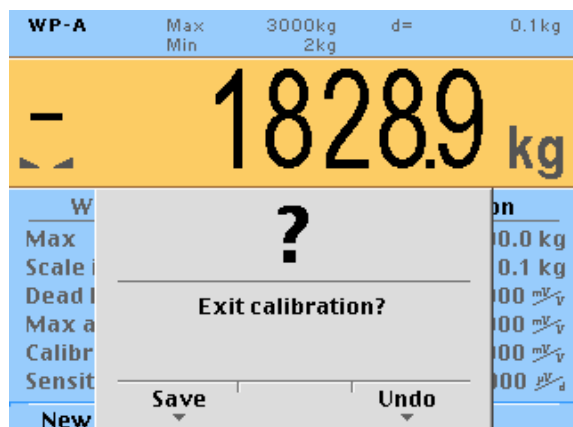

By pressing [Save] altered calibration data are saved.

The verification is displayed by "Saving calibration".

Leaving the menu is displayed by "Exit calibration".

After finishing the calibration, set the CAL switch to the closed position; see also Chapter [7.1.3.1](#).

7.12.14 Cancelling a calibration

Quit calibration by pressing the ^{Exit} softkey.

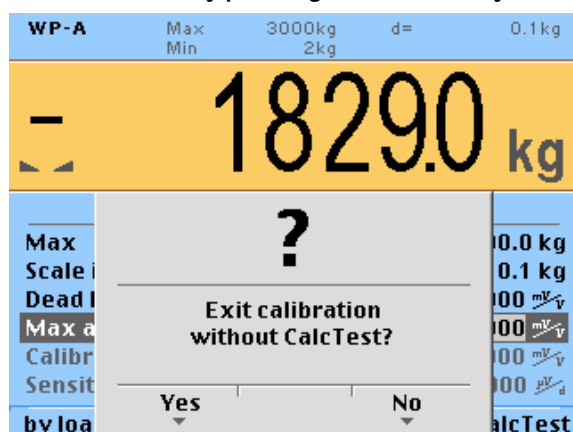

You are prompted to confirm whether calibration should be closed without determining the test value.

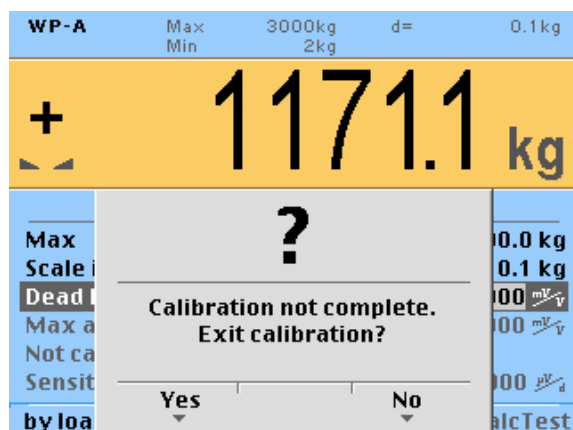

If not all data was determined when calibrating with [New] (e.g. dead load not set/entered), this message is shown:

Press [Yes] to confirm and then press again the  softkey, another prompt is displayed:

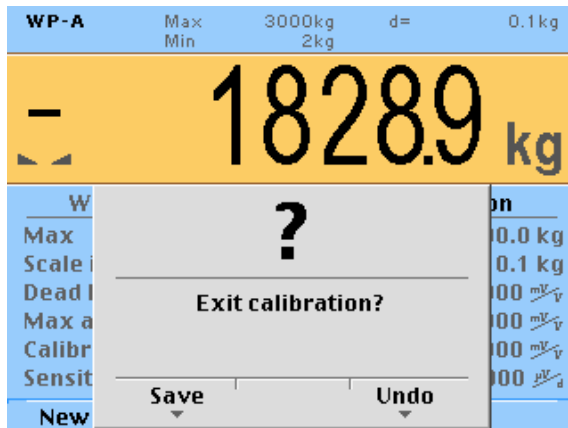

If you press [Undo], changes are not saved and the display returns to the selection menu for the weighing points.

Leaving the menu is displayed by "Exit calibration".

7.12.15 Parameter Input

The menu is accessible via  - [Weighing point] - [Calib] - [Param].

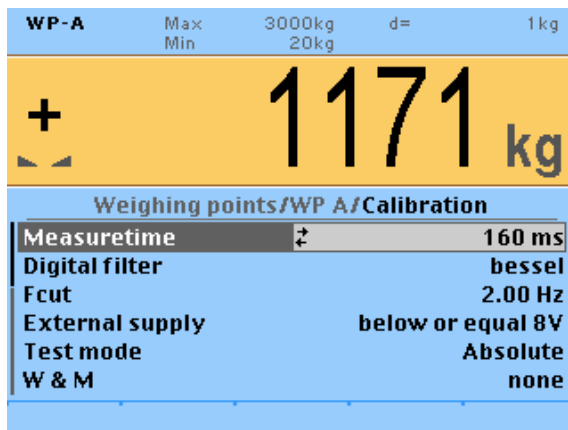

[Measuretime]

Measuring time: The duration of a measurement can be selected.

Selection: 5 ms, 10 ms, 20 ms, 40 ms, 80 ms, 160 ms, <320 ms>, 640 ms, 960 ms, 1280 ms, 1600 ms.

[Digital filter]

Selection of the digital filter (filter characteristic): <off> (no Filter), Bessel, aperiod. (aperiodic), Butterw. (Butterworth), Tcheby. (Tschebyscheff)

The following includes examples of interference signals for the different filter types:

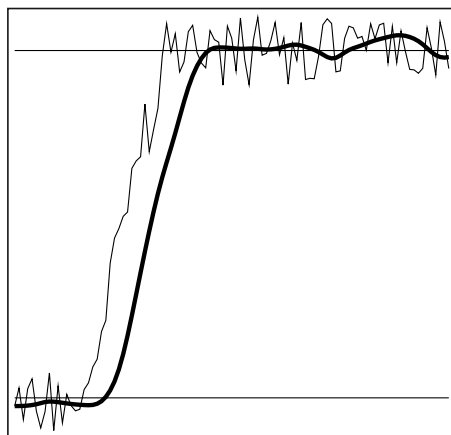
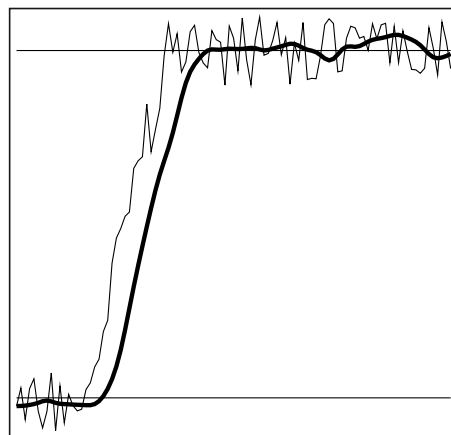
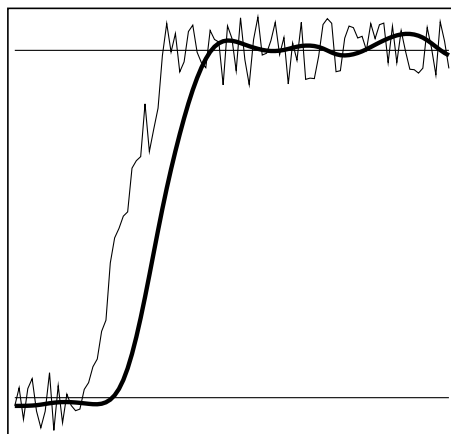
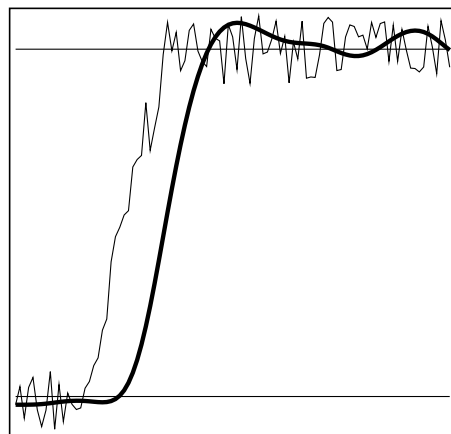
Bessel filter**Aperiodic filter****Butterworth filter****Tschebyscheff filter**

A digital filter can be switched on only with the measuring time set to <math><160\text{ ms}</math>.

If no particularly frequent fluctuations are expected in ongoing operation, the following settings are recommended:

[Measuretime]: <math><160\text{ ms}</math>

[Digital filter]: aperiod.

[Fcut]: 2.00 Hz

[Fcut]

This line only is shown if the digital filter is switched on.

The smaller the cut-off frequency, the slower the measurement and the more stable the measurement result.

The cut-off frequency can be specified for the low pass filter.

Valid range: 0.1...2.5 Hz.

The available options depend on the measuring time.

[External supply]

When the load cells are connected to an external supply, it is possible to switch to $\leq 8\text{ V}$, to tune Sense voltage monitoring to the lower supply voltage.

Selection: below or equal 8 V ($\leq 8\text{ V}$), <math><\text{above } 8\text{ V}></math> ($>8\text{ V}$)

[Test mode]

With [absolute], the test value is determined when the test is called.

With [relative], the deviation from the initially stored test value is displayed; see Chapter [7.12.12](#).

[W&M]

Setting for legal-for-trade mode.

Note:

The transmitter PR 5230 is not approved for calibration.

[Standstill time]

The parameters [Standstill time] and [Standstill range] are used to define the stability of the scale (stable balance).

The input for the parameter [Standstill time] is expressed in seconds.

Valid range: 0.00...2 s

If the tone is set to "0" there is no check. The standstill time must not be less than the measuring time.

[Standstill range]

As long as the weight fluctuations remain within this range, the device is determined to be stable.

The input for the parameter [Standstill range] is expressed in "d."

Valid range: 0.01...10.00 dc.

[Tare timeout]

Timeout for a tare/zero set command that cannot be executed (e.g. due to mechanical instability of the scale, incorrect filter setting, resolution too high, standstill condition too strict).

The input is done as seconds.

Valid range: 0.0...<2.5>...25 s.

At 0.0 s taring is only carried out when the scale is already stable.

[Zero set range]

Define a \pm range around the zero point determined by the dead load during calibration; within this range

- the displayed gross weight can be set to zero by pressing the zero-setting key (or by a corresponding external command), and
- automatic zero tracking is active.

Setting range: 0.00...10000.00 d

[Zero track indic. range]

Indication range within which automatic zero tracking compensates deviations.

Setting range: 0.25...10000.00 d

[Zero track step]

If a weight change exceeds the adjusted value, automatic tracking does not function any more.

Setting range for automatic tracking increments: 0.25...10 d

[Zerotrack time]

Time interval for automatic zero tracking.

Setting range: 0.1...25 s

At 0.0 s the zero tracking is switched off.

[Overload]

Weighing range above the maximum load (Max) without error message.

Setting range: 0...9999999 d

[Minimum weight]

Minimum weight at which a print command can be triggered.

Setting range: 0...9999999 d

[Range mode]

Selection: <Single range>, Multiple range, Multi-interval

For scale range selection, see Chapter [7.12.15.1](#) and [7.12.15.2](#).

Press the  softkey to exit the menu and to save the settings.

7.12.15.1 Multiple range scale (Class III or single range scale Class I and II with variable scale interval)

The multiple range scale is a scale with two or more weighing ranges with different maximum loads and scale intervals. There is only one load receptor, with each range covering zero to its maximum load.

When [Range mode] = [Multiple range], the scale has up to three ranges with different resolution.

The weight display header includes the current range (R1, R2, and R3), Max, Min, and d (or e with instruments used in legal metrology) (example: multiple range scale in range 2):

WP-A	R2	Max	2000kg	d=	2kg
		Min	40kg		

The [Range limit 1] and [Range limit 2] switch points are the range limits.

As soon as the gross weight exceeds range 1, the next highest range with the next highest scale interval becomes valid (1->2->5->10->20->50).

When reducing the weight, the interval of the previous range is kept. When the gross weight is ≤ 0.25 d of range 1, the scale is stable and not tared, the scale returns to range 1 with the corresponding scale interval.

Note:

During calibration, the multiple range function is always switched off.

Example:

Range mode: "Multiple range"

Range 1: 0...1000 kg (when calibrating set scale interval: 1 kg)

Range 2: 0...2000 kg (next highest scale interval: 2 kg)

Range 3: 0...3000 kg (next highest scale interval: 5 kg)

1. Choose "Range mode" from the -[Weighing point]- [Calib]- [Param] menu.

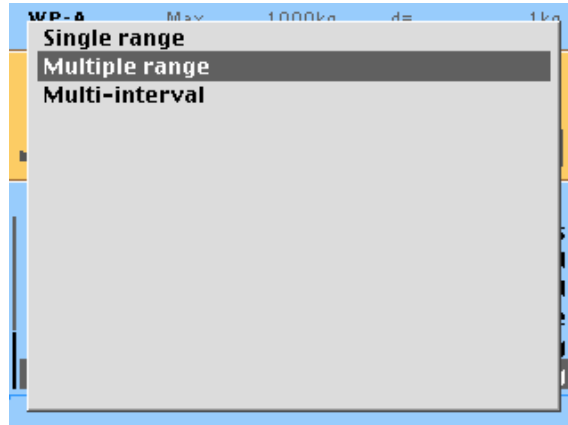

2. Select "Multiple range" and confirm.

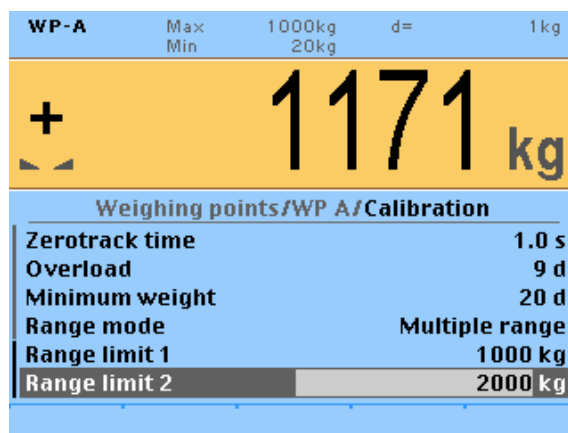

3. Setting Switch point from range 1 to 2: enter "1000 kg" for the Range limit 1.
4. Setting Switch point from range 2 to 3: enter "2000 kg" for the Range limit 2.
5. Press the Exit softkey to exit and save calibration.

7.12.15.2 Multi-interval scale (Class III or single range scale Class I and II with variable scale interval)

The multi-interval scale is a scale with a weighing range that is divided into intervals. Each interval range has a different scale interval, where the weighing range is automatically switched depending on the load on the scale and also when the load is placed on/ removed from the scale.

When [Range mode] = [Multi-interval], the scale has up to three ranges with different resolution.

The weight display header includes the current interval range (R1, R2, or R3), Max, Min, and d (or e with instruments used in legal metrology) (Example: multi-interval scale in range 2):



The parameters [Range limit 1] and [Range limit 2] are the interval ranges.

As soon as the displayed weight exceeds range 1, the next highest range with the next highest scale interval becomes valid (1->2->5->10->20->50).

Note:

During calibration, the multi-interval function is always switched off.

Example:

Range mode: "Multi-interval"

Interval range 1: 0...1500 kg (when calibrating set scale interval: 1 kg)

Interval range 2: 1500...2900 kg (next highest scale interval: 2 kg)

1. Choose "Range mode" from the -[Weighing point]- [Calib]- [Param] menu.

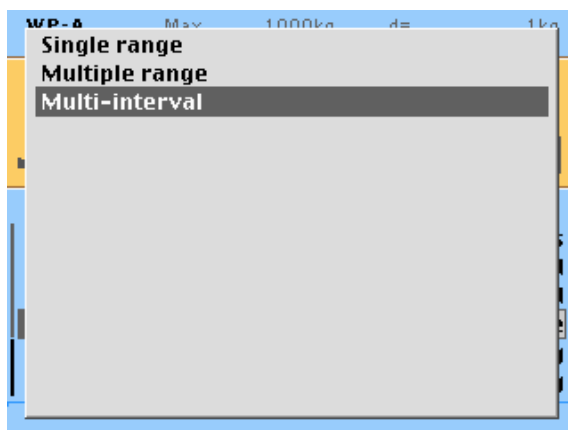

2. Select "Multi-interval" and confirm.

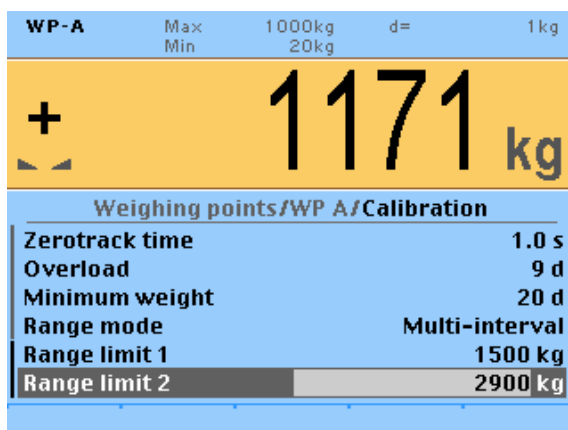

3. Setting interval range 1: Enter "1500 kg" for range limit 1.
4. Setting interval range 2: Enter "2900 kg" for range limit 2.
5. Press the  softkey to exit and save calibration.

7.13 Calibrating xBPI-scale

7.13.1 General information

The legal-for-trade application of PR 5230 with a xBPI-scale is not possible.

7.13.2 Parameters for serial interface

1. Select -[Serial ports parameter]- [xBPI-Port] and confirm.

- ▷ The following window opens:

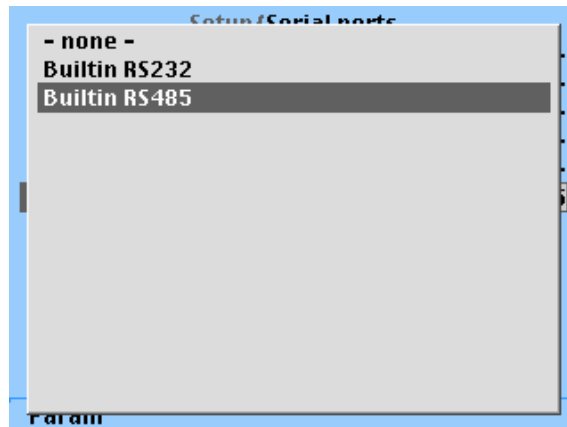

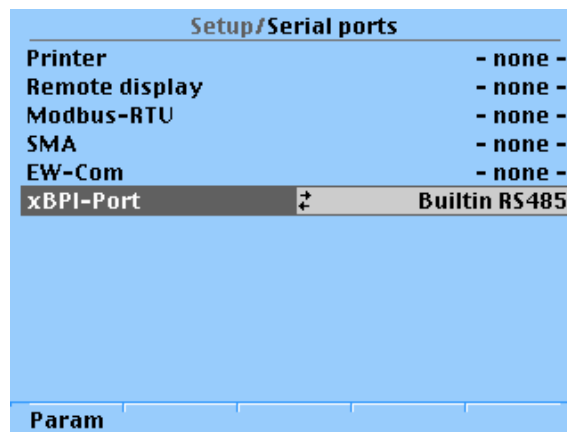

2. Select the desired interface and confirm.

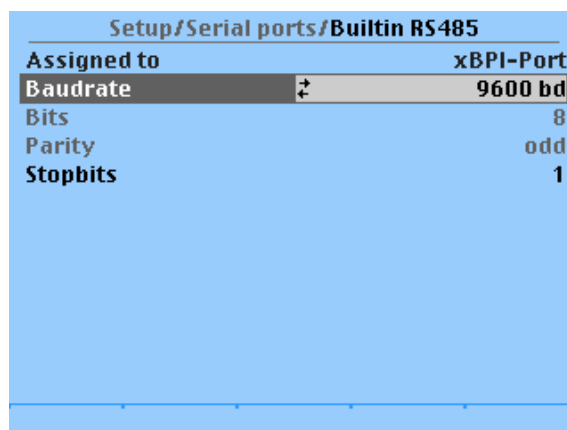

3. Press the [Param] softkey.

- ▷ The following window opens:



4. If necessary, change the parameters. Only the "baudrate" and "stop bits" can be set for an xBPI scale.
5. Press  to exit the menu and to save the settings.

7.13.3 Parameters for the xBPI-weighing function

The following parameters must be entered for this menu item:

- Timeout for tare function depending on the application
- SBN-address for each xBPI-scale in bus operation mode
- Serial number of the xBPI-scale or weighing mode with legal-for-trade application

1. Select -[Weighing point]- [xBPI-Scale] and confirm.

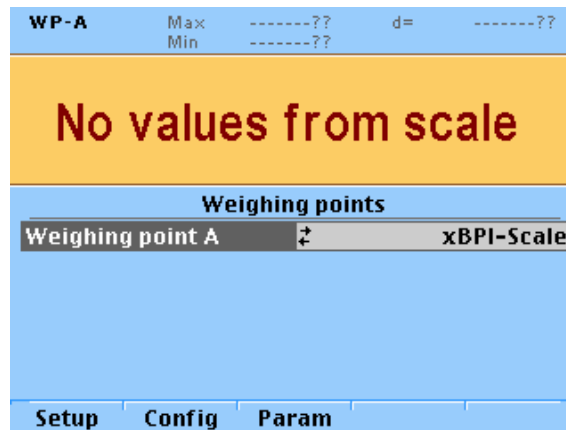

2. Press the [Config] softkey.

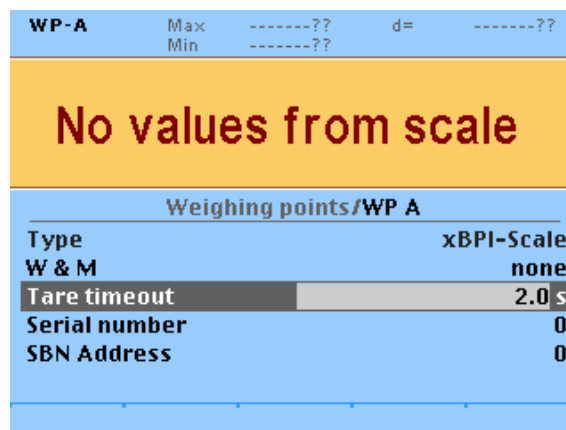

3. Enter the following parameters.

[Tare timeout]

Timeout for a zeroset or tare command to be executed.

If the xBPI scale has not executed the command in the specified time, the action will be aborted.

Setting range: 0...9.9 s

[Serial number]

Serial number of the connected xBPI scale/weighing module.

The number is required for checking when used in legal metrology.

With serial number "0", checking is omitted.

Setting range: 0...99999999

[SBN Address]

When the address is not set to 0, bus operation is active. Possible addresses: 1–31, i.e., max. 31 xBPI scales can be operated on an RS-485 branch.



The SBN Address is shown on the display.

Example: Address 31 at WP-A

4. Press to exit the menu and to save the settings.

7.13.4 Setting up an xBPI platform

1. Select -[Weighing point]- [xBPI-Scale] and confirm.

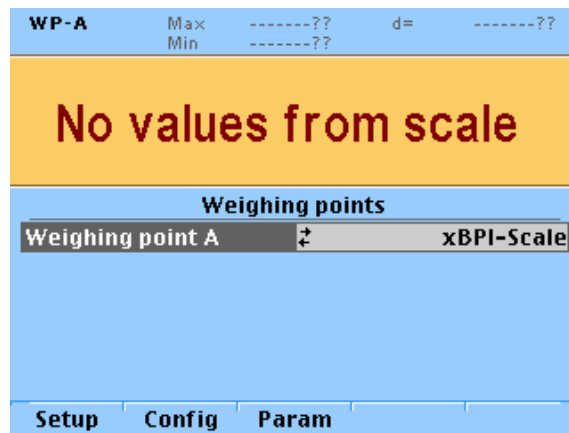

2. Press the [Setup] softkey.
 - ▷ The parameters of the xBPI-scale are read into the device.
 - Ticks indicate the progress.

An error message is displayed if communication with the xBPI scale is not possible!

The following window opens:

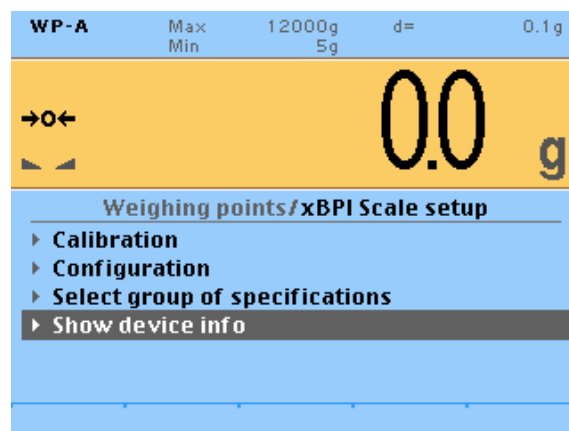

3. Select [Show device info] with the cursor and confirm.
 - ▷ The following window opens:

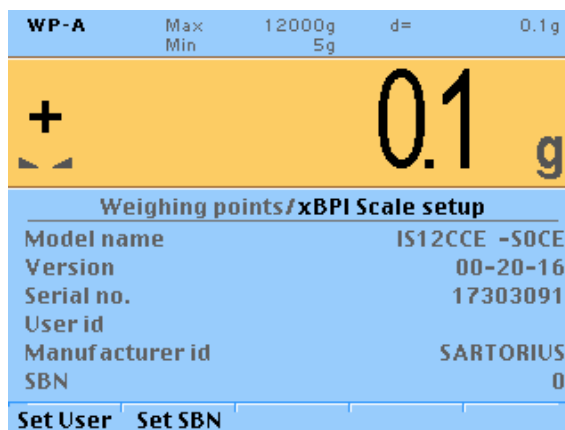

4. Change the user ID and SBN address if necessary.
5. Press the  softkey to exit the menu and to save the settings.
6. Select [Select group of specification] using the cursor and confirm.

Note:

Some xBPI platforms have what is known as "specification blocks" for selecting various modes of operation (single range, multiple range, etc.).

The following is required for the subsequent specification group selection:

- Note the model name of the scale.
 - Refer to the operating instructions for the number of the corresponding specification block.
-

7. Select and confirm the desired specification group.
8. Press the  softkey to exit the menu and to save the settings.
 - ▷ A prompt window opens.
9. Press the [Yes] softkey to save the data.
 - Press [No] for exit from the menu without data change.
 - ▷ The parameters are saved. Ticks indicate the progress.
10. Select [Configuration] using the cursor and confirm.
11. Select [Weighing parameters] with the cursor and confirm.

The parameters are listed as an overview in the following, see Chapter [7.13.5.1](#).

Note:

Only the parameters supported by the connected scale are displayed.

12. Press the  softkey to exit the menu and to save the settings.
 - ▷ A prompt window opens.
13. Press the [Yes] softkey to save the data.
 - Press [No] for exit from the menu without data change.

14. Select [Application settings] with the cursor and confirm.

The parameters are listed as an overview in the following, see Chapter [7.13.5.2](#).

Note:

Only the parameters supported by the connected scale are displayed.

15. Press the  softkey to exit the menu and to save the settings.

▷ A prompt window opens.

16. Press the [Yes] softkey to save the data.

Press [No] for exit from the menu without data change.

17. Select [Interface settings] with the cursor and confirm.

The parameters are listed as an overview in the following, see Chapter [7.13.5.3](#).

Note:

Only the parameters supported by the connected scale are displayed.

18. Press the  softkey to exit the menu and to save the settings.

▷ A prompt window opens.

19. Press the [Yes] softkey to save the data.

Press [No] for exit from the menu without data change.

7.13.5 xBPI-parameter tables

The parameters which must be entered are listed in the following tables under [Weighing point]- [Weighing point A]- [xBPI-Scale]- [Setup]- [Configuration]- [Weighing parameters]/[Application settings]/[Interface settings].

7.13.5.1 Scale parameters

[Weighing parameters]	
—	Ambient conditions
	Very stable cond.
	Stable conditions
	Unstable cond.
	Very unstable cond.
—	Application/Filter
	standard mode
	manual filling
	automatic dosing
	checkweighing
—	Stability range
	0.25 digit
	0.5 digit
	1 digit
	2 digits

- 4 digits
- 8 digits
- **Stability symb.delay**
 - no delay
 - short delay
 - long delay
 - extrem long delay
- **Tare parameter**
 - at any time
 - not until stable
- **Auto zero function**
 - Auto Zero on
 - Auto Zero off
- **Adjustment function**
 - ext.adj.w.fact.wt.
 - ext.adj.w.user.wt.
 - ext.adj.w.pres.wt.
 - internal adjust
 - ext.lin.w.fact.wt.
 - ext.lin.w.pres.wt.
 - Confirm preload
 - Delete preload
 - adjust disabled
- **Confirming adjust.**
 - automatically
 - manual
- **Zero range**
 - 1% of max load
 - 2% of max load
 - 5% of max load
 - 10% of max load
- **Power-On zero range**
 - factory settings
 - 2% of max load
 - 5% of max load
 - 10% of max load
- **Power-On tare/zero**
 - active
 - inactive
 - only for zeroing
- **Measure rate**
 - normal output
 - fast output
- **Calibration check**
 - Off
 - Calibration prompt
- **External adjustment**
 - Accessible
 - Blocked
- **Maximum capacity**
 - reduced by preload
 - constant

7.13.5.2 Application settings

[Application settings]	
— Application Tare	
— Accessible	
— Blocked	
— Number of units	
— 1 weight unit	
— 2 weight units	
— 3 weight units	
— Weight unit 1...3	
— Grams	g
— Kilogram	kg
— Carat	ct
— Pound	lb
— Ounce	oz
— Troy ounce	ozt
— Hong Kong tael	tlh
— Singapore tael	tls
— Taiwan tael	tlt
— grain	GN
— pennyweight	dwt
— milligram	mg
— Parts/pound	/lb
— Tael china	tlc
— Momme	mom
— Carat	k
— Tola	tol
— Baht	bat
— Mesghal	m
— Ton	t
— Display accuracy 1...3	
— all digits	
— reduced when moved	
— one level lower	
— two levels lower	
— three levels lower	
— 1%	
— 0.5%	
— 0.2%	
— 0.1%	
— 0.05%	
— 0.02%	
— 0.01%	
— Multi interval	
— increased by 10	

7.13.5.3 Interface parameters

[Interface settings]	
— Communication type	
— SBI protocol	
— xBPI protocol	

- **Baudrate for SBI**
 - 150 baud
 - 300 baud
 - 600 baud
 - 1200 baud
 - 2400 baud
 - 4800 baud
 - 9600 baud
 - 19200 baud
- **Parity for SBI**
 - Mark
 - Space
 - Odd
 - Even
- **Stop bits**
 - 1 stop bit
 - 2 stop bits
- **Handshake**
 - software handshake
 - CTS with 2 chr.pau
 - CTS with 1 chr.pau
- **Data output print**
 - on requ always
 - on requ when stab
 - on requ with store
 - auto
 - auto when stable
- **Auto print**
 - start/stop by ESCP
 - not stoppable
- **Output format**
 - without ID 16 byte
 - with ID 22 byte
- **Data output interval**
 - with each display
 - after 2 updates
 - after 5 updates
 - after 10 updates
 - after 20 updates
 - after 50 updates
 - after 100 updates
- **Parameter change**
 - can be changed
 - cannot be changed

g
kg
ct
lb

7.13.6 Setting the xBPI dead load

Note:

For Minebea Intec both terms "dead load" and "preload" are used.

1. Select -[Weighing point]- [xBPI-Scale] and confirm.

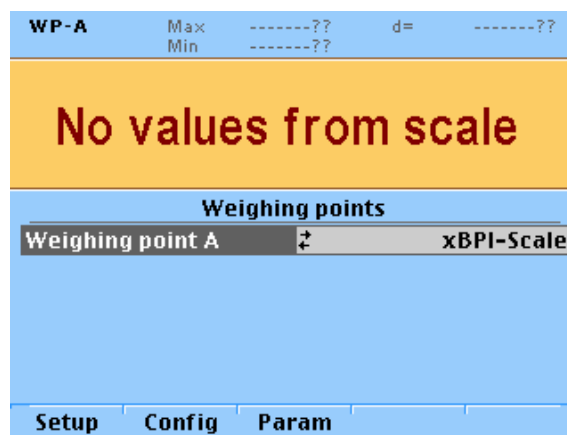

2. Press the [Setup] softkey.
 - ▷ The parameters of the xBPI-scale are read into the device.

Ticks indicate the progress.

An error message is displayed if communication with the xBPI scale is not possible!

The following window opens:

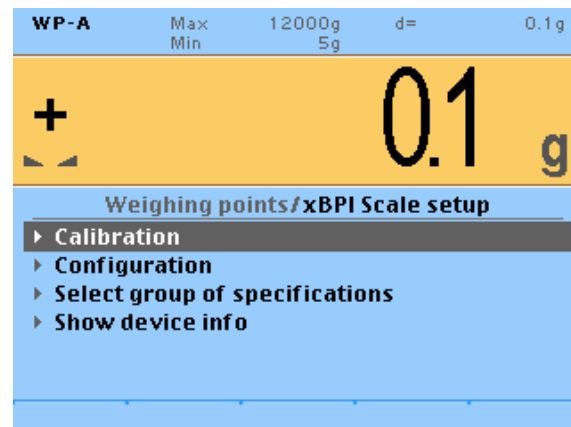

3. Select [Calibration] with the cursor and confirm.
 - ▷ The following window opens:

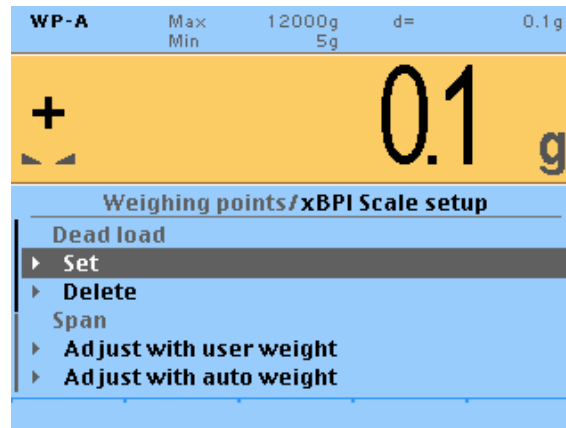

4. For setting the dead load, remove the weight from the scale and select [Set] using the cursor and confirm.
 - ▷ After sending the command, 0 is indicated on the gross weight display.
5. Alternatively, the stored dead load can be deleted: Remove the weight from the scale and select [Delete] using the cursor and confirm.
 - ▷ The stored dead load is deleted. The current dead load is shown on the weight display.
6. Press the  softkey to exit the menu and to save the settings.

7.13.7 xBPI calibration with user specified weight

Requirements:

- The xBPI protocol has been selected (see Chapter [7.13.2](#)).
- The "xBPI-scale" weighing point has been selected (see Chapter [7.13.3](#)).
- The platform has been set up (see Chapter [7.13.4](#)).
- In the menu [Weighing point A] - [xBPI-Scale] - [Setup] at [Configuration] - [Weighing parameters] - [Confirming adjust.] was set to "manual".
- The communication between the device and platform is active.

Procedure:

1. Select -[Weighing point]- [xBPI-Scale] and confirm.

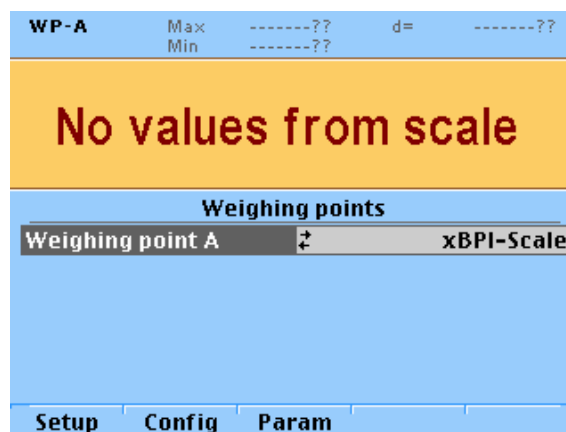

2. Press the [Setup] softkey.
 - ▷ The parameters of the xBPI-scale are read into the device.

3. Select [Calibration]- [Adjust with user weight] and confirm.
 - ▷ An input window appears. The previously stored user weight is displayed.
4. Change the weight value if necessary using the keyboard and confirm.
 - ▷ The calibration process is carried out without a weight. The calibration status is displayed.
5. Place the weight on the scale.
 - ▷ The deviation is displayed in the last line with increased resolution (10-fold).
6. Press the [Accept] softkey.
 - ▷ The data are saved and the instrument returns the following message:

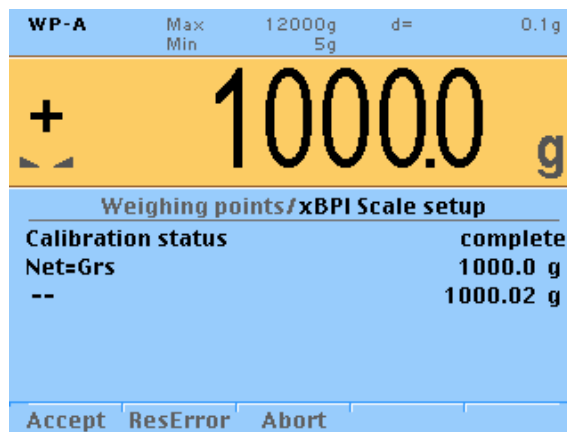

The weight is displayed in high-resolution (10x).

7. Remove the weight.
8. Press the  softkey to exit the menu and to save the settings.

7.13.8 xBPI calibration with automatic weight detection

Requirements:

- The xBPI protocol has been selected (see Chapter [7.13.2](#)).
- The "xBPI-scale" weighing point has been selected (see Chapter [7.13.3](#)).
- The platform has been set up (see Chapter [7.13.4](#)).
- In the menu [Weighing point A] - [xBPI-Scale] - [Setup] at [Configuration] - [Weighing parameters] - [Confirming adjust.] was set to "manual".
- The communication between the device and platform is active.

Procedure:

1. Select -[Weighing point]- [xBPI-Scale] and confirm.

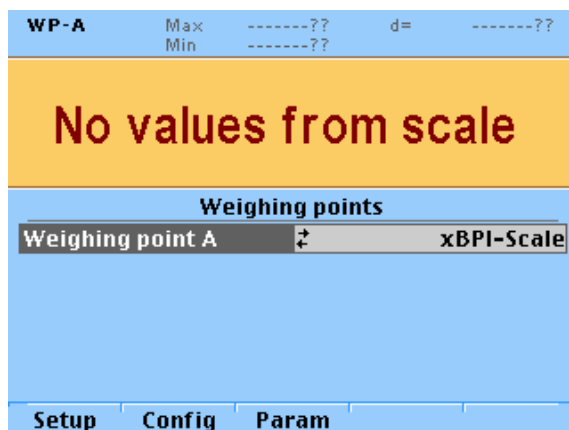

2. Press the [Setup] softkey.
 - ▷ The parameters of the xBPI-scale are read into the device.
3. Select [Calibration]- [Adjust with auto weight] with the cursor and confirm.
 - ▷ The calibration process is carried out without a weight. The calibration status is displayed.
The weight is specified automatically.
4. Place the displayed weight on the scale.
5. Press the [Accept] softkey.
 - ▷ The data are saved.
The weight is displayed in high-resolution (10x).
6. Remove the weight.
7. Press the  softkey to exit the menu and to save the settings.

7.13.9 xBPI calibration with default weight

Requirements:

- The xBPI protocol has been selected (see Chapter [7.13.2](#)).
- The "xBPI-scale" weighing point has been selected (see Chapter [7.13.3](#)).
- The platform has been set up (see Chapter [7.13.4](#)).
- In the menu [Weighing point A] - [xBPI-Scale] - [Setup] at [Configuration] - [Weighing parameters] - [Confirming adjust.] was set to "manual".
- The communication between the device and platform is active.

Procedure:

1. Select -[Weighing point]- [xBPI-Scale] and confirm.

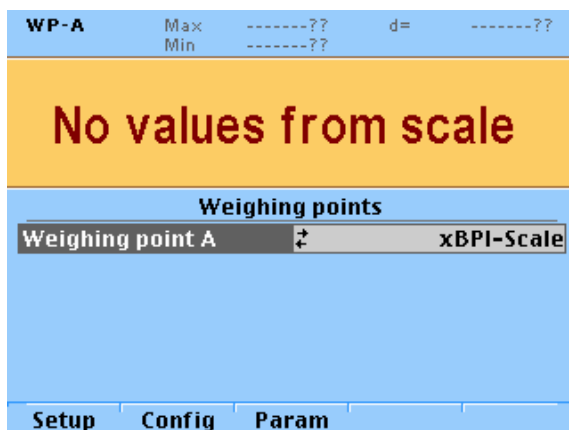

2. Press the [Setup] softkey.
 - ▷ The parameters of the xBPI-scale are read into the device.
3. Select [Calibration]- [Adjust with default weight] with the cursor and confirm.
 - ▷ The calibration process is carried out without a weight. The calibration status is displayed.
 - The weight is specified automatically.
4. Place the displayed weight on the scale.
 - ▷ The deviation is displayed in the last line with increased resolution (10-fold).
5. Press the [Accept] softkey.
 - ▷ The data are saved.
 - The weight is displayed in high-resolution (10x).
6. Remove the weight.
7. Press the  softkey to exit the menu and to save the settings.

7.13.10 xBPI calibration with built-in weight

Requirements:

- The xBPI protocol has been selected (see Chapter [7.13.2](#)).
- The "xBPI-scale" weighing point has been selected (see Chapter [7.13.3](#)).
- The platform has been set up (see Chapter [7.13.4](#)).
- In the menu [Weighing point A] - [xBPI-Scale] - [Setup] at [Configuration] - [Weighing parameters] - [Confirming adjust.] was set to "manual".
- The communication between the device and platform is active.

Procedure:

1. Select -[Weighing point]- [xBPI-Scale] and confirm.

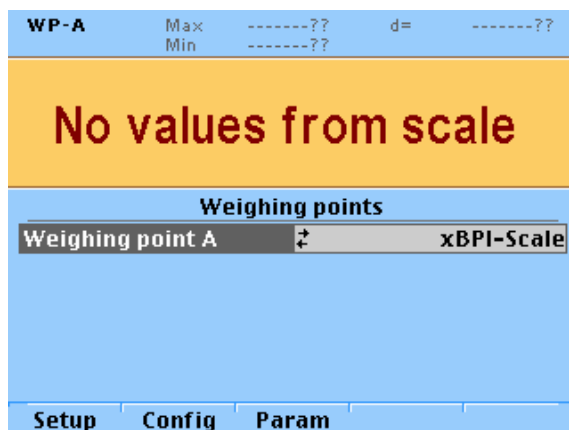

2. Press the [Setup] softkey.
 - ▷ The parameters of the xBPI-scale are read into the device.
3. Select [Calibration]- [Adjust with intern weight] with the cursor and confirm.
 - ▷ The procedure is displayed by status messages in a row.
 - The deviation is displayed in the last line with increased resolution (10-fold).
4. Press the [Accept] softkey.
 - ▷ The date are saved.
 - The weight is displayed in high-resolution (10x).
5. Press the  softkey to exit the menu and to save the settings.

7.13.11 xBPI linearization

The measurement range for a straight can be optimized by setting the linearization points. The following describes standard linearization.

Requirements:

- The xBPI protocol has been selected (see Chapter [7.13.2](#)).
- The "xBPI-scale" weighing point has been selected (see Chapter [7.13.3](#)).
- The platform has been set up (see Chapter [7.13.4](#)).
- In the menu [Weighing point A] - [xBPI-Scale] - [Setup] at [Configuration] - [Weighing parameters] - [Confirming adjust.] was set to "manual".
- The communication between the device and platform is active.

Procedure:

1. Select -[Weighing point]- [xBPI-Scale] and confirm.

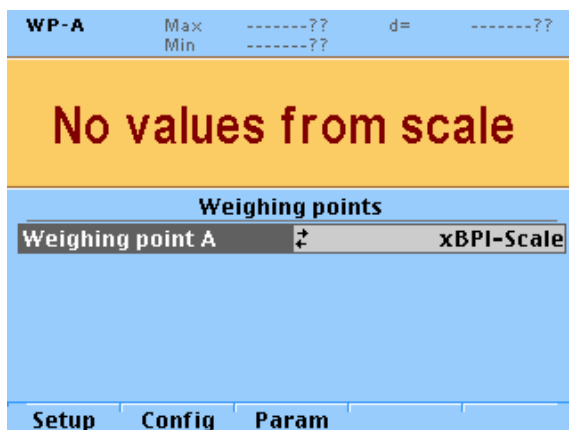

2. Press the [Setup] softkey.
 - ▷ The parameters of the xBPI-scale are read into the device.
3. Select [Calibration]- [Linearity: Default] using the cursor and confirm.
 - ▷ The first linearization point to be calibrated is displayed.
4. Place the displayed weight on the scale.
 - ▷ The deviation is displayed in the last line with increased resolution (10-fold).
5. Press the [Accept] softkey.
 - ▷ The second linearization point to be calibrated is displayed.
6. Place the displayed weight on the scale.
 - ▷ The deviation is displayed in the last line with increased resolution (10-fold).
7. Press the [Accept] softkey.
 - ▷ The third linearization point to be calibrated is displayed.
8. Place the displayed weight on the scale.
 - ▷ The deviation is displayed in the last line with increased resolution (10-fold).
9. Press the [Accept] softkey.
 - ▷ The last linearization point to be calibrated is displayed.
10. Place the displayed weight on the scale.
 - ▷ The deviation is displayed in the last line with increased resolution (10-fold).
11. Press the [Accept] softkey.
12. Press the  softkey to exit the menu and to save the settings.

7.14 Calibrating digital load cells of type "Pendeo"

7.14.1 General information

The digital load cells have been calibrated at the factory based on the acceleration of gravity at Hamburg (9.81379 m/s^2). The calibration data in the load cells are invariable. The calibration data for the gravity acceleration at the place of installation can be adapted only in the instrument and protected against overwriting (see Chapter 7.1.3.1).

With legal-for-trade applications, the legal requirements and the conditions given on the test/approval certificate must be taken into account when selecting the settings.

For connecting digital load cells (xBPI load cells), firmware version 3.10 or higher must be installed.

The available interfaces are visible under -[Show HW-slots].

7.14.2 Selecting and configuring RS-485 interface

1. Select -[Serial ports parameter]- [xBPI-Port] and confirm.

▷ The following window opens:

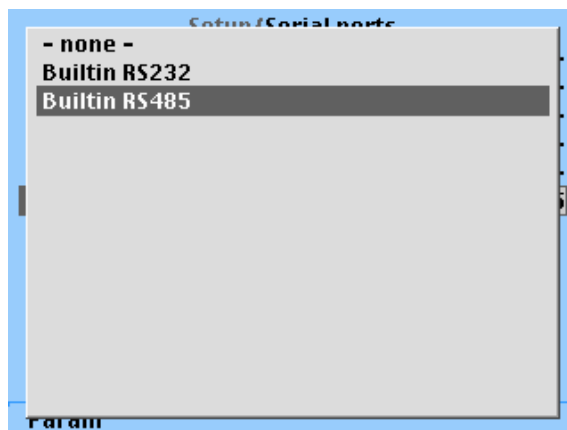

2. Select the desired interface and confirm.

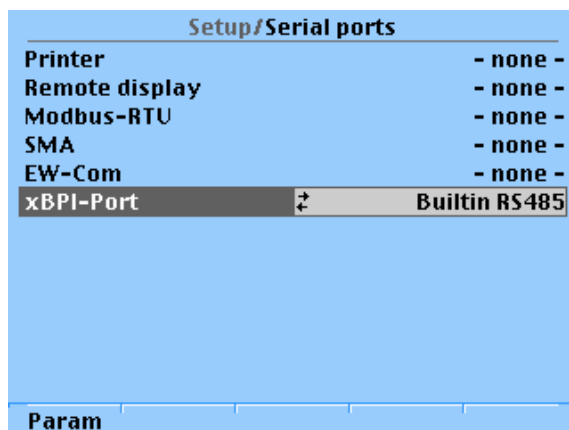

3. Press the [Param] softkey.

▷ The following window opens:

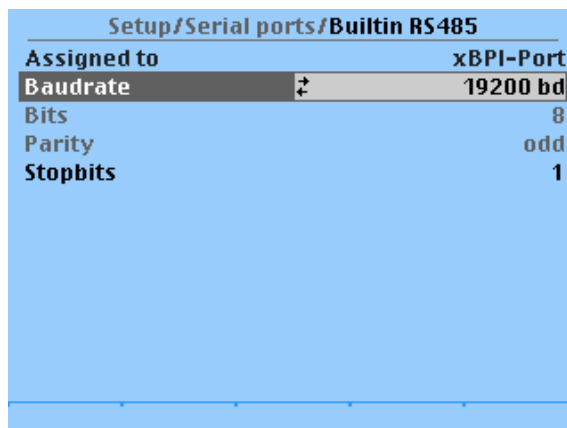

4. Select [Baudrate] and confirm.

▷ A selection window opens.

5. Select "19200 bd" and confirm.
6. Select [Stopbits] and confirm.
 - ▷ A selection window opens.
7. Select "1" and confirm.
8. Press  to exit the menu and to save the settings.

7.14.3 Selecting the load cell type

1. Select -[Weighing point]- [Weighing point A].
 - ▷ A selection window opens.
2. Select "Pendeo Load Cells" and confirm.

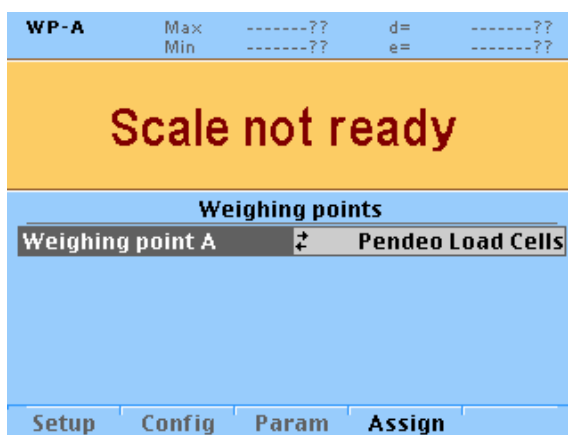

3. Press  to exit the menu and save.

7.14.4 Calibration procedure

During calibration, no data is changed in the digital load cells. The calibration data and parameters are saved in the instrument. The unique serial numbers of the connected load cells are monitored.

For the calibration the following order must be followed:

- Search for load cells, see Chapter [7.14.5](#).
- Assign load cells, see Chapter [7.14.6](#).
- Recalibrate: Maximal load with weight unit, scale interval, dead load, CAL weight, see Chapter [7.14.7](#).
- Perform a corner correction if necessary; see Chapter [7.14.10.3](#).

Note:

For further information about calibrating weighing points, see Chapter [7.12.3](#).

7.14.5 Searching load cells

1. Select -[Weighing point]- [Weighing point A].

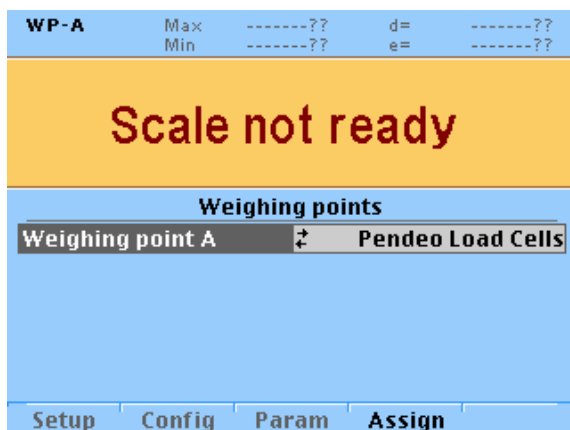

2. Press the [Assign] softkey.

▷ The following window opens:

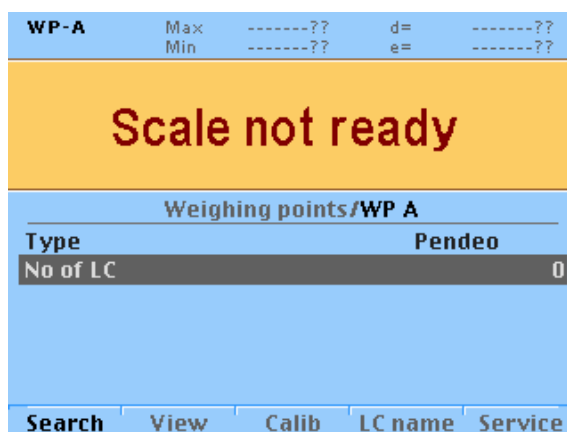

3. Press the [Search] softkey.

▷ A prompt window opens.



4. Press the [Continue] softkey to start a new search process.

Press the [Cancel] softkey to accept and display the existing values.

▷ A window with load cell information opens

[Type]

Type of load cells

[No of LC]

Number of load cells

[LC 1...n]

Serial number/name of the load cells

[WP serial number]

Weighing point serial number(is displayed after search)

5. Press the [View] softkey.
 - ▷ The load cells are displayed with their item number, serial number, and load.
6. Select the desired load cell and press the [Info] softkey.
 - ▷ The load cell data is displayed.

Note:

If load cell names have been assigned (see Chapter [7.14.8](#)), the view can be switched with the [by name] softkey.

7. Press  to exit the menu and save.

7.14.6 Assigning load cells

The load cells (serial number) can be assigned to the place of installation in this menu. This is important for correcting the dead load (distribution to the individual load cells), for corner correction and in the event of load cell replacement.

An example of a possible assignment is shown below.

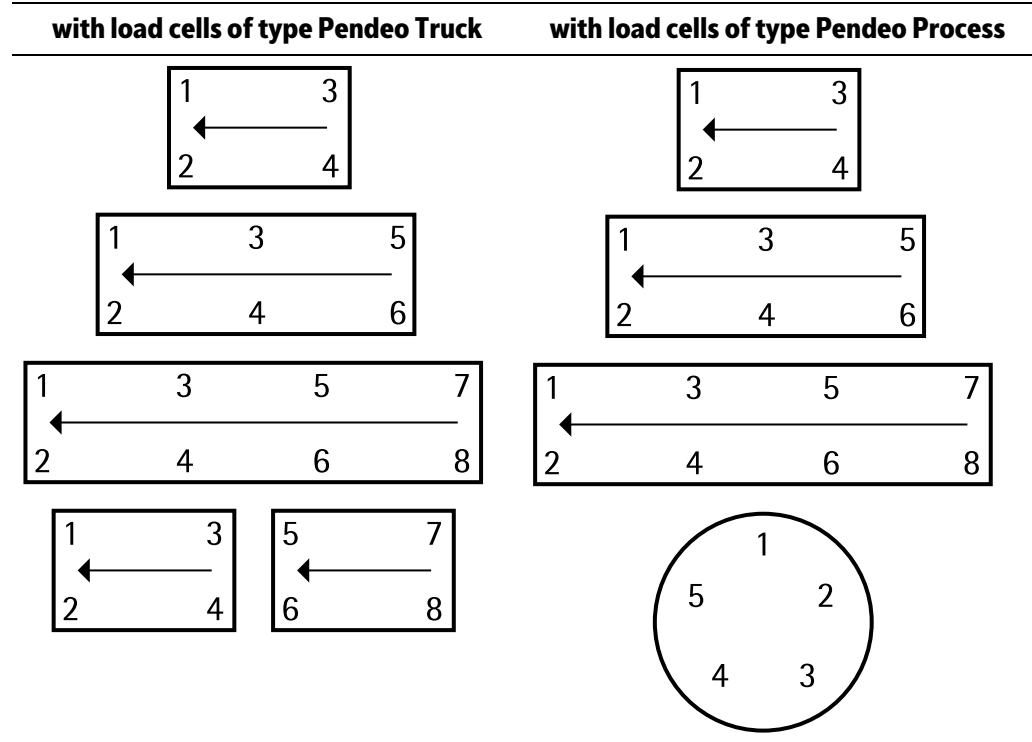

Note:

The assignment from the installation should be documented in the case of load cells being replaced.



The menu is accessed via - [Weighing point] - [Weighing point A] - [Assign] - [View] .

1. Unload the scale.
2. Press the [Assign] softkey.
 - ▷ You are prompted to confirm.
3. Press the [Continue] softkey to reset the dead load information and start the assignment procedure.
4. Press the [Cancel] softkey to not start the assignment.
 - The load cells are assigned by placing minimum weights on the scale (approx. 50 kg).
5. Place the weight on the corner/load cell which will be assigned no. 1 later.
 - As soon as the device detects the weight change, the corresponding line is selected.
6. Confirm the assignment of the first load cell by selecting .
 - ▷ The future LC no. is shown at the far right of the line.
7. Remove the weight.

8. Repeat these steps for load cells 2...4.
9. Press the [Accept] softkey.
10. Press the  softkey to exit the menu and save.
11. Press the [View] softkey.
 - ▷ The new assignment will be displayed.
12. Check the corner load (dead load); see Chapter [7.14.10.1](#).
13. Press the  softkey to exit the menu and save.

7.14.7 Calibrating load cells

The menu is accessed via  - [Weighing point] - [Weighing point A] - [Assign] .

Note:

The [Modify] menu item is only used for small changes (e.g., changing the dead load/preload, changing the mV/V values for dead load/preload and/or Max, changing the scale interval). Otherwise select the [New] menu item.

Example:

Maximum capacity of a load cell: $E_{max} = 50 \text{ t}$

Number of load cells: 4

Max: 200.000 t

Scale interval: 0.020 t

Dead load: Empty weight

CAL weight: 11.000 t

Procedure:

1. Press the [Calib] softkey.
 - ▷ A window opens.
 - For Max the sum of the maximum capacities for load cell are factory settings:
 $4 \times 50 \text{ t} = 200 \text{ t}$
2. Press the [New] softkey.
 - ▷ The data is set to factory settings (default) first before calibration is started.
 - A prompt window opens.
3. Press the [Yes] softkey to reset the corner correction and the calibration to continue.
 - ▷ The "Calibration window" opens.
4. Entering and verifying parameters.

[Local gravity]

Entering the local value of gravitational acceleration (in this example: Hamburg 9.81379 m/s^2), see e.g. <http://www.ptb.de/cartoweb3/SISproject.php>.

[Number of platforms] (only for Pendeo Truck-load cell)

This parameter is shown only in the case of 8 load cells.

Entering the number of platforms.

[Number of vessel feet] (only for Pendeo Process-load cells)

Enter the number of vessel feet.

Note:

The number of vessel feet and the number of load cells may differ, e.g.: 4 vessel feet on 1 pivots and 3 load cells.

[Max]

The load cell capacity is suggested as Max ($E_{\max} \times$ number of load cells).

The maximum load (Max) determines the maximum measured weight without dead load. Normally, the selected Max must be smaller than the load cell capacity (maximum capacity \times number of load cells) – dead load, in order to prevent overloading the load cells.

Enter the maximum load with decimal places (in this example: 200.000 t).

The  key can be pressed to switch between units.

[Scale interval]

Selecting the scale interval (1 d) (in this example: 0020).

The scale interval (d) is calculated, based on the maximum weight value.

[Dead load]

To use the empty scale as dead load (normal case):

- Do not load scale.
- Press the [by load] softkey.

Note:

If the dead load is known, the value can be overwritten [by value].

[CAL weight]

- Center the CAL weight on the scale and enter the weight value with decimal places (here: 11.000 t).
- Press the [Ok] softkey and remove CAL weight.

[Corner correction]

Perform a corner correction if necessary; see Chapter [7.14.10.3](#).

Note:

During calibration the weight can be displayed with 10 fold resolution by pressing the  key.

After 5 seconds the display returns to normal resolution. Press  if you want to switch to normal resolution immediately.

5. Press the  softkey to exit the menu.

7.14.8 Assigning load cell names

In this menu the load cells can also be assigned names in addition to the load cell no. and serial numbers.

The menu is accessible via  - [Weighing point] - [Weighing point A] - [Assign] - [LC name] .

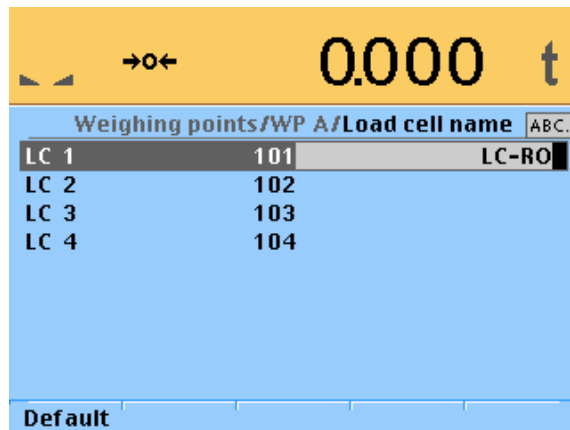

Weighing points/WP A/Load cell name			ABC..
LC 1	101	LC-RO	
LC 2	102		
LC 3	103		
LC 4	104		

Default

1. Select the line, enter the name with the keyboard (max. 20 alphanumerical characters) and confirm.
2. Repeat these steps for load cells 2...4.
3. Press  to exit the menu and save.

7.14.9 Service function

In this menu faulty load cells can be deactivated and replaced load cells activated.

The menu is accessible via  - [Weighing point]- [Weighing point A]- [Assign]- [Service].
The service window appears.

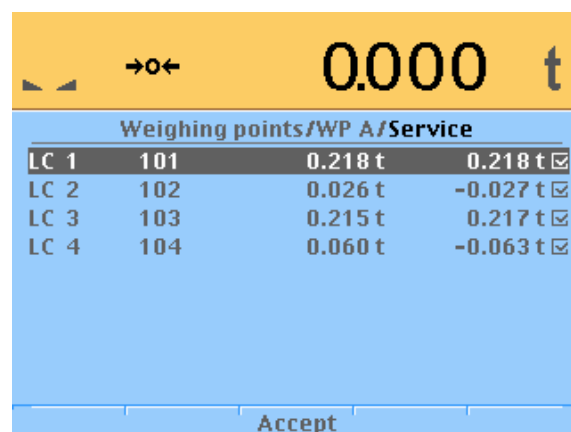

Weighing points/WP A/Service			
LC 1	101	0.218 t	0.218 t <input checked="" type="checkbox"/>
LC 2	102	0.026 t	-0.027 t <input checked="" type="checkbox"/>
LC 3	103	0.215 t	0.217 t <input checked="" type="checkbox"/>
LC 4	104	0.060 t	-0.063 t <input checked="" type="checkbox"/>

Accept

Item number, serial number, dead load and current weigh of connected load cells are displayed.

7.14.9.1 Deactivating the load cell

A load cell can be deactivated if it is defective. The weight is then distributed to the remaining load cells.

Note:

For vehicle weighbridges:

Trucks should only be allowed to move onto the center of the weighing platform, in order to distribute the weight evenly.

1. Select the faulty load cell and confirm, to deactivate the cell.

Weighing points/WP A/Service			
LC 1 deactivated		0.218 t	0.218 t <input type="checkbox"/>
LC 2	102	0.026 t	-0.027 t <input checked="" type="checkbox"/>
LC 3	103	0.215 t	0.217 t <input checked="" type="checkbox"/>
LC 4	104	0.060 t	-0.062 t <input checked="" type="checkbox"/>

Accept

2. Press the [Accept] softkey.
 - ▷ The warning symbol replaces the weight unit.

Weighing points/WP A/Service			
LC 1 deactivated		0.218 t	0.218 t <input type="checkbox"/>
LC 2	102	0.026 t	-0.026 t <input checked="" type="checkbox"/>
LC 3	103	0.215 t	0.217 t <input checked="" type="checkbox"/>
LC 4	104	0.060 t	-0.062 t <input checked="" type="checkbox"/>

Accept

7.14.9.2 Activating the load cell

1. After inserting and connecting the new load cell, select the line of the deactivated load cell and confirm.
2. Press the [Accept] softkey.
 - ▷ A search process is started and only then is the new load cell detected.

7.14.10 Corner correction

7.14.10.1 Checking the corner load (dead load)

Note:

For scale structures with containers pay attention to the following:

- For asymmetric scale structures a corner correction is not necessary.
 - But for symmetric scale structures corner correction may be required.
-

After assignment and calibration, the load cell positions have been defined clearly.

7.14.10.2 Mechanical corner correction

A Mechanical corner correction has to be carried out, if the load is not evenly distributed over the load cells, e.g. if the platform is wobbling.

The dead load on the load cells can be corrected using shims. If two coupled platforms are connected, corner load checking or installation of shims for the platforms must be performed independently.

A fine calibration can be done by software corner correction, see Chapter [7.14.10.3](#).

7.14.10.3 Software corner correction

If the corners are loaded in succession, the same value should be displayed on the device at all times. An excessive deviation almost always means that the scale is tilted or indicates load cell force shunts.

If the signal deviations cannot be resolved by carefully leveling the scale, the software must be calibrated.

The menu is accessible via -[Weighing point]- [Weighing point A]- [Assign].

1. Press the [Modify] softkey.
2. Select and confirm [Corner correction].
3. Set the CAL weight on an area of the scale structure.
 - ▷ The position (e.g.: LC 4) is highlighted.
4. Confirm this position.
 - ▷ Is displayed by .
5. Remove the CAL weight.
6. Repeat steps 3 to 5 for the remaining load cells. You are free to choose any desired order.
7. If all load cells have been loaded one time, press the [Calc] softkey to perform the corner correction.
 - ▷ The total weight remains unchanged. Only the effect of the individual load cells is corrected.
When corner correction is completed, it is marked with "OK".
8. Press  to exit the menu and save.

7.14.11 Terminating/saving calibration

The calibration is terminated by pressing the  key.

Unless all data were determined during recalibration using [New] (e.g. dead load not set/entered), the following prompt is displayed:

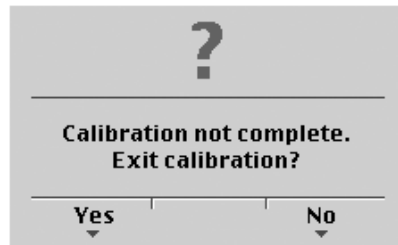

1. Press the [Yes] softkey to exit the calibration.
2. Confirm .
 - ▷ A prompt window opens.

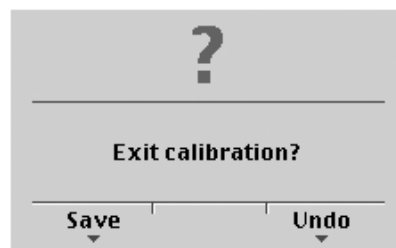

3. Press the [Save] softkey to save changes in calibration data.
 - ▷ The verification is displayed by "Saving calibration".
4. Press the [Undo] softkey if you do not want to save the changes.
 - ▷ The scale returns to the selection menu.
 - Leaving the menu is displayed by "Exit calibration".
5. After finishing calibration, set the CAL switch to the closed position; see Chapter [7.1.3.1](#).

7.14.12 Parameter Input

The menu is accessible via  - [Weighing point] - [Weighing point A] - [Assign] - [Calib] - [Param].

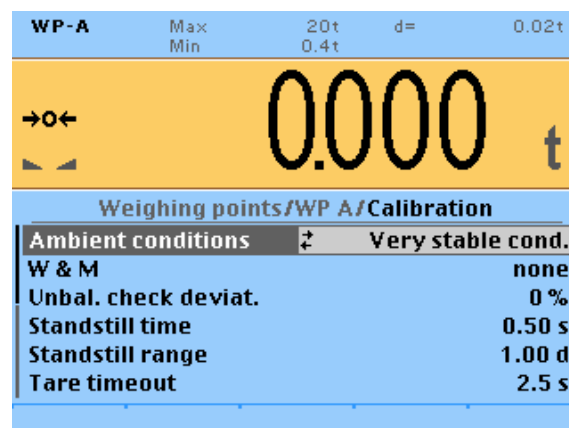

[Ambient conditions]

This parameter is used to define the ambient conditions of the scale.

Possible Selections: very stable condition, stable condition, unstable condition, very unstable condition

[W&M]

Setting for legal-for-trade mode.

Note:

The transmitter PR 5230 is not approved for calibration.

[Unbal. Check deviat.]

The plausibility check is activated when the average deviation is >0%. The average deviation of the individual load cells is calculated.

Setting range: 0...100%.

[Standstill time]

The parameters [Standstill time] and [Standstill range] are used to define the stability of the scale (stable balance).

The input for the parameter [Standstill time] is expressed in seconds.

Valid range: 0.00...2 s

If the time is set to "0" there is no check. The standstill time must not be less than the measuring time.

[Standstill range]

As long as the weight fluctuations remain within this range, the device is determined to be stable.

The input for the parameter [Standstill range] is expressed in "d."

Valid range: 0.01...10.00 dc.

[Tare timeout]

Timeout for a tare/zero set command that cannot be executed (e.g. due to mechanical instability of the scale, incorrect filter setting, resolution too high, standstill condition too strict).

The input is done as seconds.

Valid range: 0.0...<2.5>...25 s.

At 0.0 s taring is only carried out when the scale is already stable.

[Zero set range]

Define a \pm range around the zero point determined by the dead load during calibration; within this range

- the displayed gross weight can be set to zero by pressing the zero-setting key (or by a corresponding external command), and
- automatic zero tracking is active.

Setting range: 0.00...10000.00 d

[Zero track indic. range]

Indication range within which automatic zero tracking compensates deviations.

Setting range: 0.25...10000.00 d

[Zerotrack step]

If a weight change exceeds the adjusted value, automatic tracking does not function any more.

Setting range for automatic tracking increments: 0.25...10 d

[Zerotrack time]

Time interval for automatic zero tracking.

Setting range: 0.1...25 s

At 0.0 s the zero tracking is switched off.

[Overload]

Weighing range above the maximum load (Max) without error message.

Setting range: 0...9999999 d

[Minimum weight]

Minimum weight at which a print command can be triggered.

Setting range: 0...9999999 d

[Range mode]

Selection: <Single range>, Multiple range, Multi-interval

For scale range selection, see Chapter [7.12.15.1](#) and [7.12.15.2](#).

Press  to exit the menu and to save the settings.

7.14.13 Subsequent dead load correction

If the hopper/platform weight changes by an amount that is higher than the zero-setting range; e.g. due to dead load reduction, dead load increase, or mechanical changes, the functions for automatic zero tracking and manual zero setting no longer work.

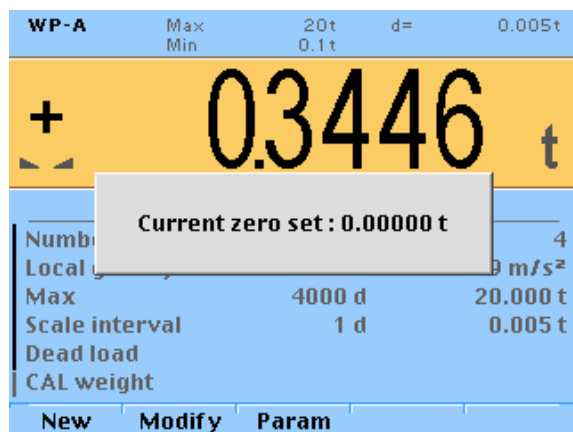

To view the range which is already utilized by zero tracking or zero setting, in [Calibration] press the  key; this also activates 10-fold increased resolution of the weight value.

Press  again to return to the previous state.

Note:

The scale must not be loaded!

If the entire zero-setting range is already utilized, you can still correct the dead load subsequently without affecting other calibration data/parameters. To do this open calibration via -[Weighing point]- [Weighing point A]- [Assign]- [Calib]- [Modify] and determine the dead load with [Dead load] using the [by load] option (see Chapter [7.14.7](#)).

7.14.14 Displaying weighing point serial number

After searching via -[Weighing point]- [Weighing point A]- [Assign]- [Search] the corresponding weighing point serial number is displayed.

7.15 General parameter settings

The parameter settings which are not related to the weighing electronics are divided into several ranges.

- Serial interfaces [Serial ports parameter]
- Date and Time [Date & Time]
- Operating parameter [Operating parameter]
- Printing parameter [Printing parameter]

Note:

This menu item is only available if under -[Operating parameter]- [Application] "Standard" has been selected.

- Fieldbus parameter [Fieldbus parameter]
- Network parameter [Network parameter]
- Configuring display [Display items]
- Configuring limits [Limit parameter]

Note:

This menu item is only available if under -[Operating parameter]- [Application] "Standard" has been selected.

- Configuring digital inputs and outputs [Digital i/o parameter]

Note:

This menu item is only available if under -[Operating parameter]- [Application] "Standard" has been selected.

- Configuring analog output [Analog output parameter]

7.15.1 Selecting and configuring serial interfaces

The interfaces are configured under this menu item.

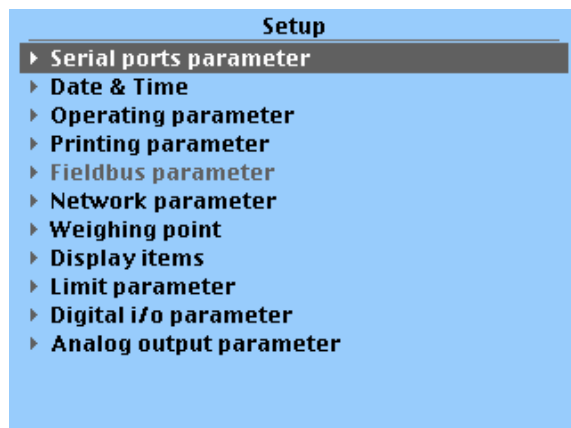

- ▶ Select  - [Serial ports parameter] and confirm.
- ▷ The following window opens.

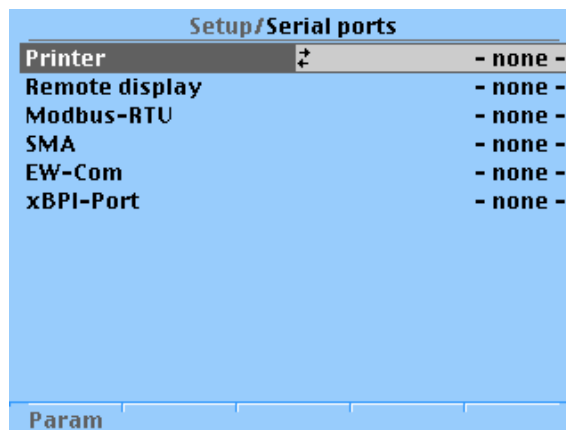

7.15.1.1 Printer protocol

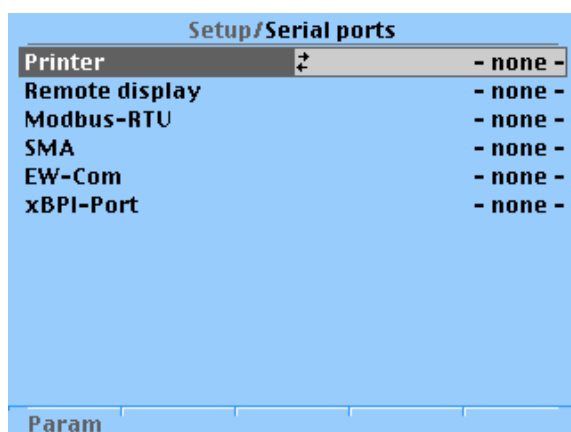

1. Select [Printer] and confirm.
 - ▷ A selection window opens.
2. Select the desired interface and confirm.

- ▷ The selected interface is displayed.

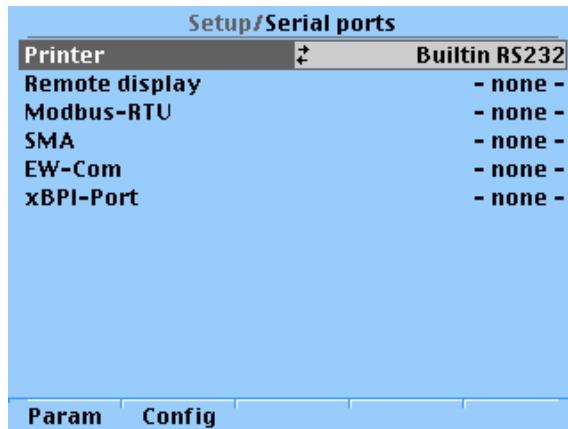

3. Press the [Param] softkey to set the parameters.

- ▷ The following window opens:

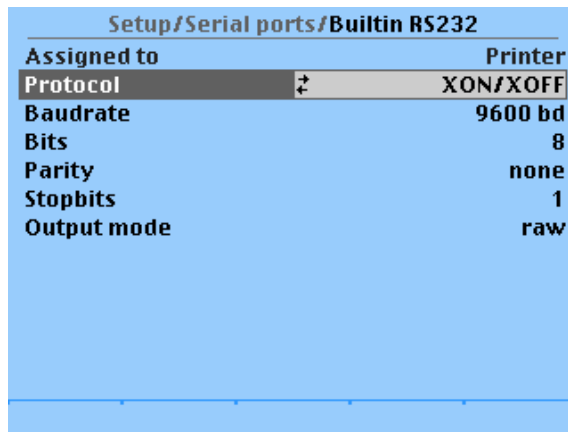

4. Select parameters and confirm.
5. Select and confirm the desired printer settings in the respective selection window.
6. Press ^{Exit} to return to the previous window.
7. Press the [Config] softkey to define the print settings.

- ▷ The following window opens:

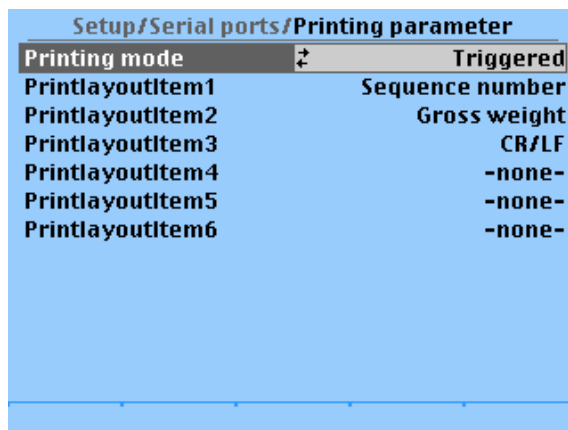

8. Select parameters and confirm.
9. Select and confirm the desired printer settings in the respective selection window.

10. Press  two times to exit the menu and save.

7.15.1.2 Remote display protocol

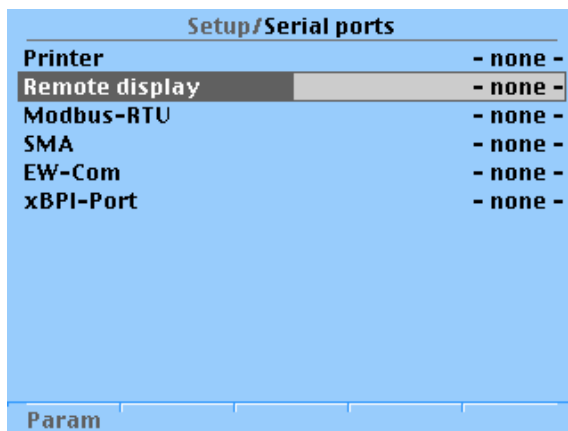

- Select [Remote display] and confirm.
 - ▷ A selection window opens.
- Select the desired interface and confirm.
 - ▷ The selected interface is displayed.

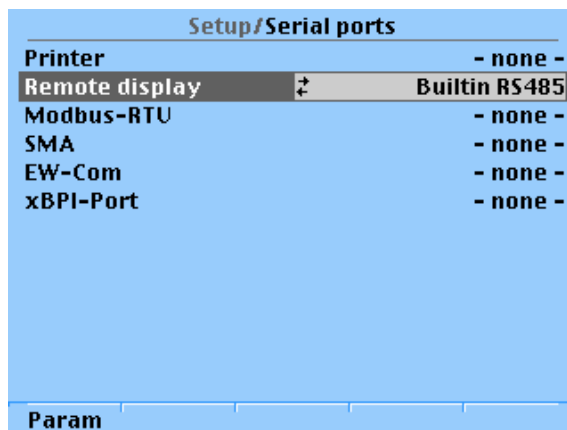

- Press the [Param] softkey to set the parameters.
 - ▷ The following window opens:

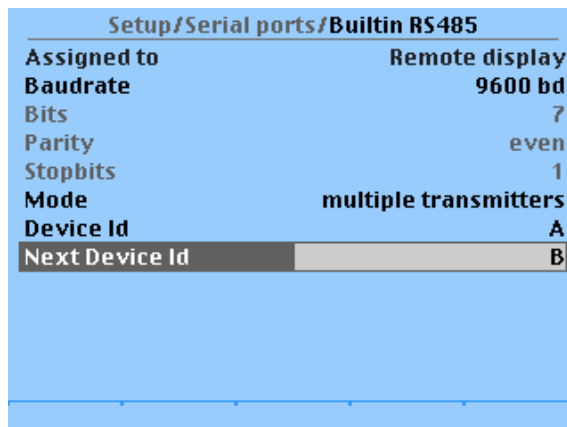

- Select [Baudrate] and confirm.
 - ▷ A selection window opens.

5. Select the desired transmission speed and confirm.
6. Select [Mode] and confirm.
7. If several remote displays are connected, select the "multiple transmitters" mode. If only 1 instrument is connected to a remote display (normal case), [Mode] must be set to "single transmitter".
8. Enter the unique device address (in this case: A) and the address of the device that follows (in this case: B) and confirm.
9. Press Exit two times to exit the menu and save.

7.15.1.3 ModBus RTU protocol

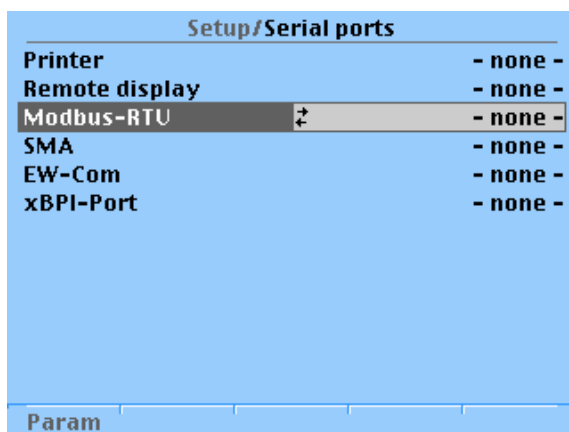

1. Select [ModBus-RTU] and confirm.
 - ▷ A selection window opens.
2. Select the desired interface and confirm.
 - ▷ The selected interface is displayed.

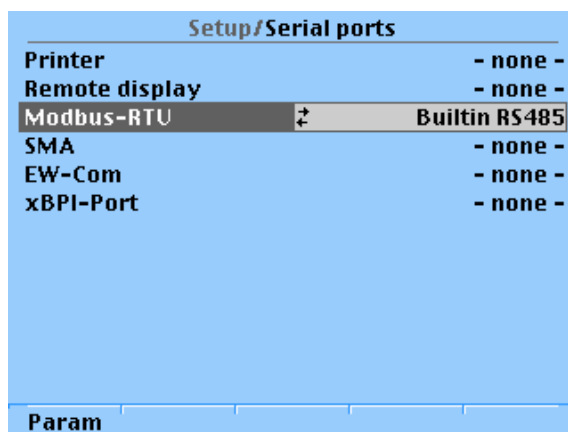

3. Press the [Param] softkey to set the parameters.

- ▷ The following window opens:

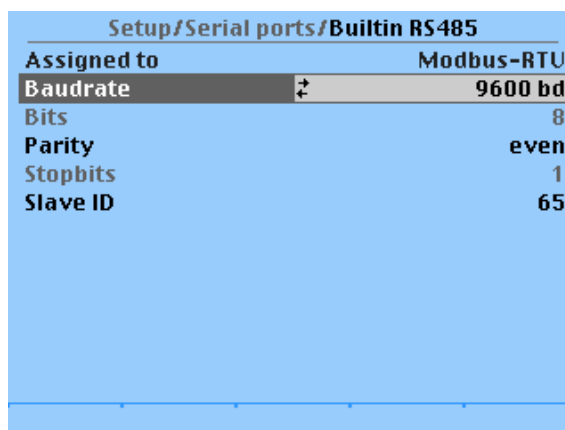

4. Select [Baudrate] and confirm.
 - ▷ A selection window opens.
5. Select the desired transmission speed and confirm.
6. Select [Parity] and confirm.
 - ▷ A selection window opens.
7. Select the desired parity and confirm.
8. Select [Slave ID] and confirm.
9. Enter and confirm the slave address (in this case: 65).
10. Press ^{Exit} 2x to exit the menu and save.

7.15.1.4 SMA protocol

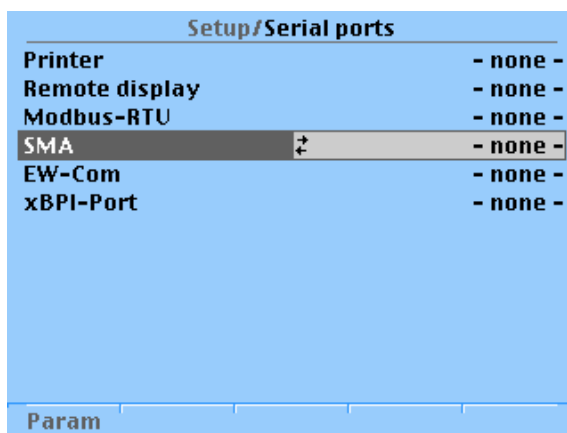

1. Select [SMA] and confirm.
 - ▷ A selection window opens.
2. Select the desired interface and confirm.

- ▷ The selected interface is displayed.

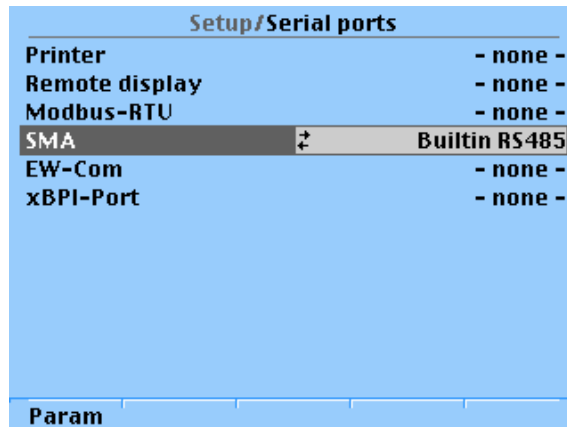

3. Press the [Param] softkey to set the parameters.

- ▷ The following window opens:

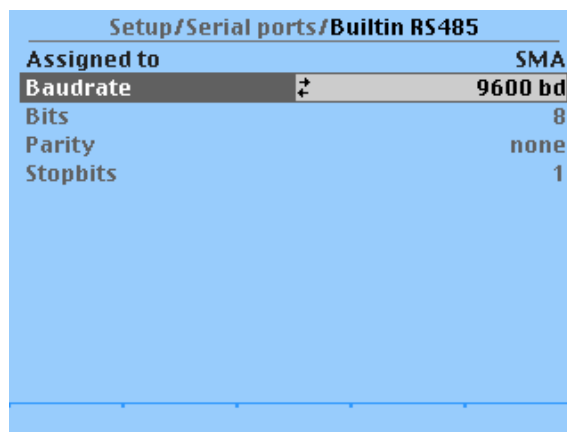

4. Select [Baudrate] and confirm.
 - ▷ A selection window opens.
5. Select the desired transmission speed and confirm.
6. Press ^{Exit} two times to exit the menu and save.

7.15.1.5 EW-Com protocol

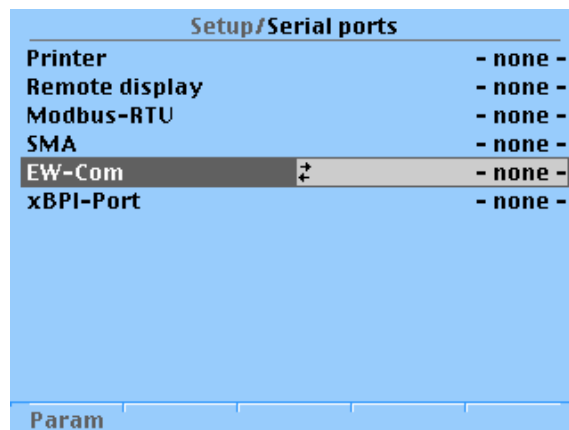

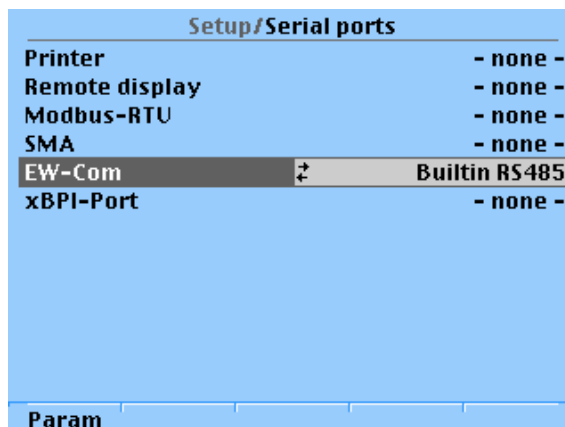

1. Select [EW-COM] and confirm.
 - ▷ A selection window opens.

2. Select the desired interface and confirm.
 - ▷ The selected interface is displayed.

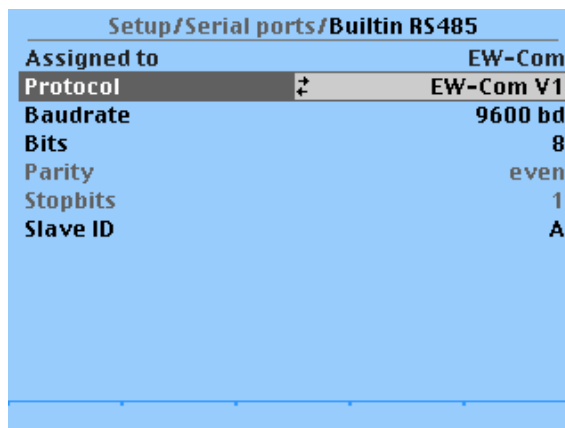

3. Press the [Param] softkey to set the parameters.
 - ▷ The following window opens:



4. Select [Protocol] and confirm.
 - ▷ A selection window opens.
 - V1 = for old communication programs
 - V2 = for formulation controller
 - V3 = for OPC
5. Confirm the desired selection.
6. Select [Baudrate] and confirm.
 - A selection window opens.
7. Select the desired transmission speed and confirm.
8. Select [Bits] and confirm.
 - A selection window opens.
9. Select the desired bit quantity and confirm.
10. Select [Slave ID] and confirm.
11. Enter the address (A–Z) and confirm.
12. Press  two times to exit the menu and save.

7.15.1.6 xBPI protocol

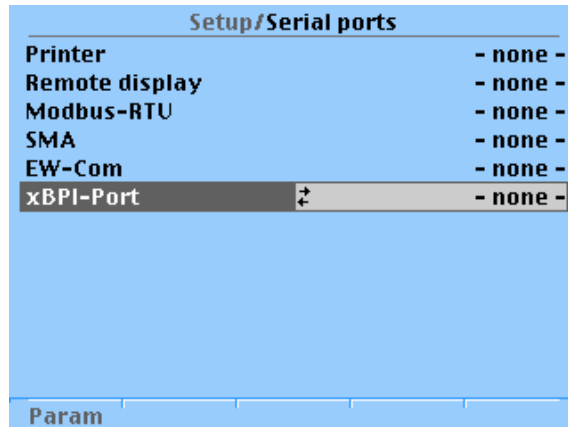

1. Select [xBPI-Port] and confirm.
 - ▷ A selection window opens.
2. Select the desired interface and confirm.
 - ▷ The selected interface is displayed.

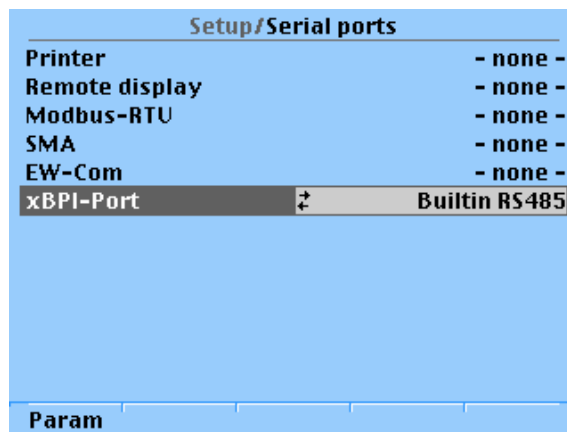

3. Press the [Param] softkey to set the parameters.
 - ▷ The following window opens:

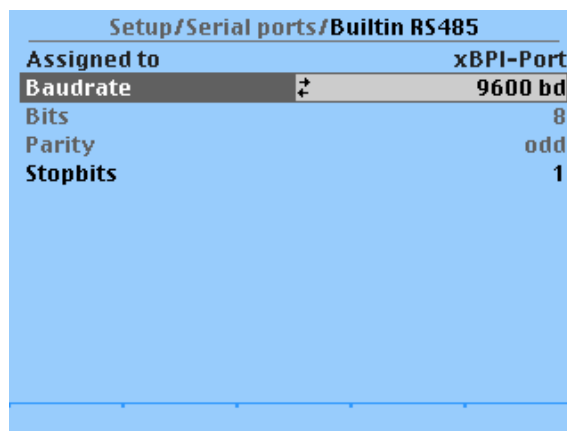

4. Select [Baudrate] and confirm.
 - ▷ A selection window opens.
5. Select the desired transmission speed and confirm.

6. Select [Stopbits] and confirm.
 - ▷ A selection window opens.
7. Select the desired stopbit and confirm.
8. Press  two times to exit the menu and save.

7.15.2 Date and time

The date and time are set under this menu item.

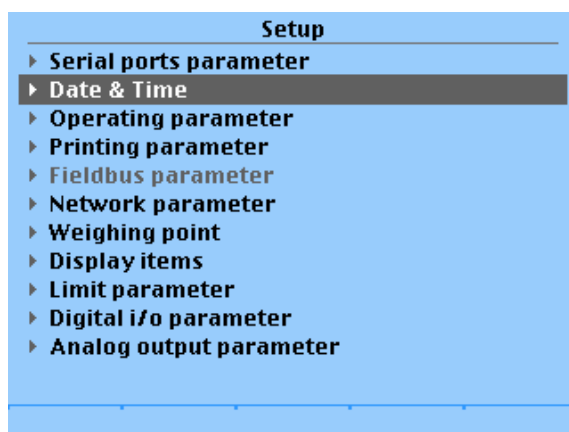

1. Select [Date & Time] and confirm.
 - ▷ The following window opens:

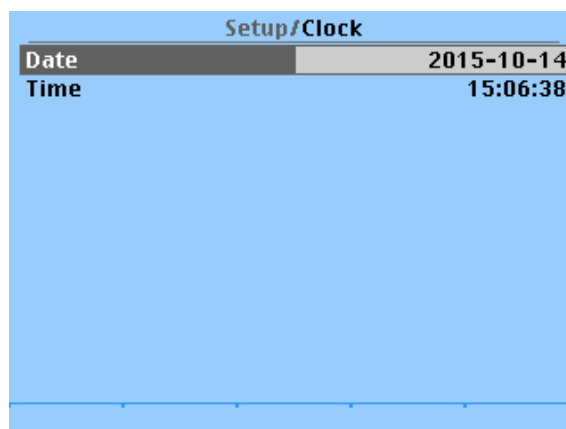

2. Select the individual digits and use the keypad to overwrite them and confirm.

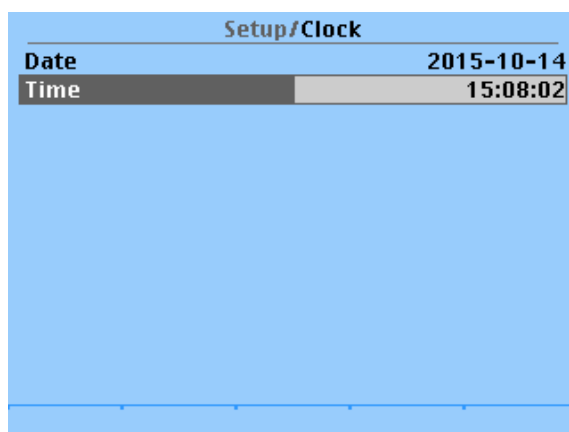

3. Select the individual digits and use the keypad to overwrite them and confirm.
4. Press  to exit the menu and save.

7.15.3 Operating parameters

The operating parameters are set under this menu item.

Open the menu via -[Operating parameter].

Setup/Operating parameter	
Application	Standard
Address	A
PIN	0
Sequence number	9044537
Set Tare Key	tare & reset tare
Set zero key	only when not tared

[Application]

Application selection: Standard, EasyFill

[Address]

Enter device address, e.g. for printout.

Input: A...Z

[PIN]

The access code can be used to protect the system setup from unauthorized operation.

Input: number with up to 6 digits

As long as you are in this menu, the value can be overwritten as required.

If the [PIN] is set to "0", no access code prompt is displayed.

Note:

SUPER PIN

If the PIN-Code is lost, the setup can be unlocked with Super-PIN "212223."

[Sequence number]

The sequence number (counter for print jobs) is incremented automatically (max. 999999999) and can be set to a start value here as appropriate.

The sequence number can also be shown on the printout (selectable).

Note:

This menu item is only available if under -[Operating parameter]- [Application] "Standard" has been selected.

[SetTareKey]

Selection: disabled, tare & reset tare, tare & tare again

The tare function (operation via VNC/Internet Browser) can be toggled:

- [tare & reset tare] means that the device will be tared if it has not been tared previously and the tare will be reset if the device has already been tared.
- [tare & tare again] means that each time a tare command is given, the instant value in the tare memory is applied and the net display switches to 0.

The tare key has no function when set to [disabled].

[SetZeroKey]

Selection: disabled, only when not tared, reset tare on zeroset

The function of the zero-setting key (operation via VNC/Internet Browser) can be restricted with [only when not tared] to the gross mode or automatically toggle with [reset tare on zeroset] to the gross mode.

If the zero-setting key with these settings has no effect, the configured zero-setting range (around the zero-point set with the dead load) is already utilized due to a previous zero-setting operation and/or automatic zero setting.

The setting to zero is deactivated by [disabled].

Press  to return to the Setup menu.

The following prompt window appears if parameters were changed.

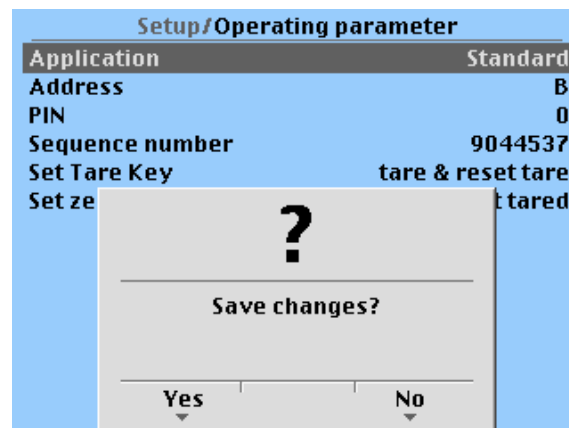

Save the data with [Yes].

Press [No] to exit the menu without changing data.

7.15.4 Print parameters**Note:**

This menu item is only available if under -[Operating parameter]- [Application] "Standard" has been selected.

The print parameters are set under this menu item.

Open the menu via -[Printing parameter].

Setup/Printing parameter	
Printing mode	Cyclic
Printing interval	10
Printing interval unit	Seconds
PrintlayoutItem1	Sequence number
PrintlayoutItem2	Gross weight
PrintlayoutItem3	CR/LF
PrintlayoutItem4	-none-
PrintlayoutItem5	-none-
PrintlayoutItem6	-none-

[Printing mode]

Printing mode

Selection: <Triggered> trigger one printout, Cyclic, Cyclic with enable

[Printing interval]

Printing interval

This menu item only appears if the [Cyclic] or [Cyclic with enable] printing mode has been selected.

Input: 1...250

[Printing interval unit]

Unit of the printing interval

Selection: Seconds, Minutes, Hours, Meas. time

[Printlayout Item 1...6]

Print layout for line 1...6

Selection: -none- (no printout; selected if fewer than 6 elements will be printed), Gross weight, Net weight, Tare weight, Date & Time (printed in format DD.MM.YYYY HH:MM:SS), Sequence number (counter for individual print orders, max. 6 digits, #000001 comes after #999999), CR/LF (carriage return and line feed), Device address, displayed weight, Formfeed

Note:

If [OIML], [NTEP], or [NSC] has been selected, printing is done only if the stability criteria is fulfilled.

The weight is shown in "<>".

For [NTEP] or [NSC] the gross weight is indicated with G (otherwise B).

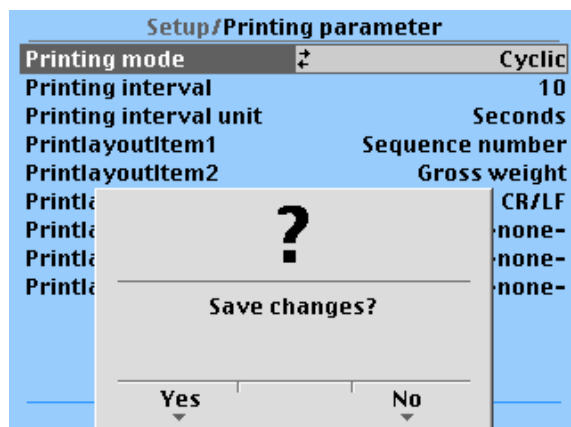

Press  to return to the Setup menu.

The following prompt window appears if parameters were changed.



Save the data with [Yes].

Press [No] to exit the menu without changing data.

If a printer has been connected and set up (see Chapter 7.15.1.1), the configuration printout can be triggered via the  and  keys (clicked one after the other).

7.15.5 Fieldbus parameters

The fieldbus parameters are set under this menu item.

Open the menu via -[Fieldbus parameter].

This menu item can only be selected if a fieldbus card is installed.

The protocol displayed automatically depends on of the installed fieldbus card:

- [ProfiBus-DP] for PR 1721/41
- [InterBus-S] for PR 1721/42
- [DeviceNet] for PR 1721/44
- [CC-Link] for PR 1721/45

Note:

This fieldbus card does **not** support the "EasyFill" application.

- [ProfiNet I/O] for PR 1721/46
- [EtherNet-IP] for PR 1721/47

Example:

PR 1721/46 ProfiNet I/O

Setup/Fieldbus parameter	
Fieldbus protocol	Profinet
IP address	172.24.22.125
Subnet mask	255.255.240.0

Note:

The individual parameters depend on the fieldbus type.

Press  to return to the Setup menu.

The following prompt window appears:

Setup/Fieldbus parameter	
Fieldbus protocol	Profinet
IP address	172.24.22.125
Subnet mask	255.255.240.0

?	
Save changes?	
Yes	No

Save the data with [Yes].

Press [No] to exit the menu without changing data.

7.15.5.1 ProfiBus-DP settings for S7**Requirements:**

- PR 1721/41 ProfiBus-DP is installed.
- The parameters are selected and saved.

Card test:

The device display shows the fieldbus card status.

Under  - [HW-Slots] - [Slot 2] all inputs and outputs are displayed.

Procedure:

1. Establish communication with the PLC (here: SIEMENS S7-300/400 or S7-1500).
2. Create/open a project in the "SIMATIC MANAGER."

3. Load the file "sart5230.gsd" from CD and install it in the development environment.
4. Add the PR 5230 device to the project and assign the I/O ranges.

Note:

See Chapter [12.2](#)

Example:

The gross weight should be read.

I/O size = 8 bytes, counted from byte 0–7

7.15.5.2 DeviceNet settings for Rockwell workstation

Requirements:

- PR 1721/44 DeviceNet is installed.
- The parameters are selected and saved.

Card test:

The device display shows the fieldbus card status.

Under  - [HW-Slots] - [Slot 2] all inputs and outputs are displayed.

Procedure:

1. Register the file "sag_5230.eds" using the "Hardware Installation Tool".
2. Select and insert the instrument from the catalog into the I/O configuration.

Note:

See Chapter [12.2](#)

Example:

The gross weight should be read.

I/O size = 8 bytes, counted from byte 0–7

7.15.5.3 ProfiNet I/O settings for S7

Requirements:

- PR 1721/46 ProfiNet I/O is installed.

Card test:

The device display shows the fieldbus card status.

Under  - [HW-Slots] - [Slot 2] all inputs and outputs are displayed.

Procedure:

1. Establish communication with the PLC (here: SIEMENS S7-300/400 or S7-1500).

NOTICE**Potential network problems**

- ▶ A unique device name must be assigned for the hardware configuration and assignment/download.

2. Enter the IP address and network mask under  - [Fieldbus parameter] and confirm.
3. Add the PR 5230 device to the project and assign the I/O ranges.

Note:

See Chapter [12.2](#)

Example:

The gross weight should be read.

I/O size = 8 bytes, counted from byte 0–7

4. Assign the instrument name to the PR 5230.

7.15.5.4 EtherNet-IP settings for Rockwell workstation**Requirements:**

- PR 1721/47 DeviceNet EtherNet-IP is installed.

Card test:

The device display shows the fieldbus card status.

Under  - [HW-Slots] - [Slot 2] all inputs and outputs are displayed.

Procedure:

1. Enter the IP address and network mask under  - [Fieldbus parameter] and confirm.
2. Register the file "sag_5230_Ethernetip.eds" using the "Hardware Installation Tool".
3. Select and insert the instrument from the catalog into the I/O configuration.

Note:

See Chapter [12.2](#)

Example:

The gross weight should be read.

I/O size = 8 bytes, counted from byte 0–7

7.15.6 Network parameters

Under this menu item, you can define the network parameters for the network connections (built-in LAN adapter).

Open the menu via  - [Network parameter].

Setup/Network parameter	
HW address	00:90:6C:6A:6B:5E
Hostname	PR5230-6A6B5E
Use DHCP	<input checked="" type="checkbox"/>
IP address	172.24.20.187
Subnet mask	255.255.240.0
Default gateway	172.24.16.1
Remote access	
VNC-Client	255.255.255.255

[HW address]

This parameter cannot be changed because the fixed address is specified by the instrument.

[Hostname]

NOTICE

Potential network problems

- The host name must be unique in the network!

The user-defined device name is subject to the following restrictions:

- Minimum number of characters: 2, maximum number of characters: 24.
- The first character must be a letter. Spaces are not permitted.
- 0–9, A-Z (not case-sensitive) are permitted.
- - or . may be included, but neither at the end nor in succession.

Input: via keypad

[DHCP]

If is checked (presettings: DHCP selected), the server automatically allocates the IP address, subnet mask, and default gateway.

If is not checked, the settings [IP address], [Subnetmask] and [Default gateway] must be defined in consultation with the responsible system administrator.

[VNC client]

This address can be used to allow access to the interface for remote access, see following table.

User	address	Description
VNC client	0.0.0.0.	Access via VNC not permitted.
VNC client	172.24.21.101	Access only from client machine with this address.

User	address	Description
VNC client	172.24.21.255	Access from any client with address within range 172.24.21.1 - ..254.
VNC client	255.255.255.255	Access from client with any address.

Note:

When setting [IP Address], [Subnetmask], and [Default gateway], please consult with your system administrator.

Press  to return to the Setup menu and to save the changes.

7.15.7 Configuring display

The lines of the display are set under this menu item.

Open the menu via -[Display items] .

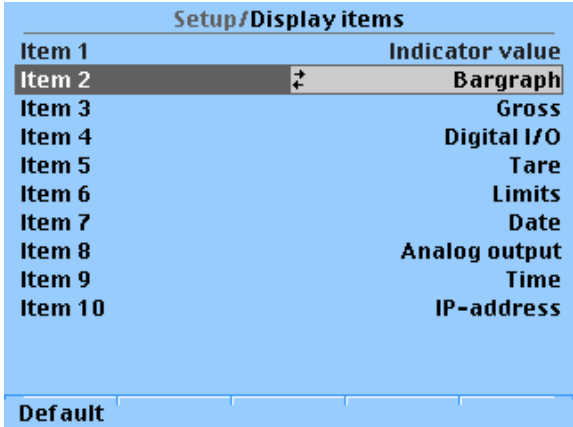

Setup/Display items	
Item 1	Indicator value
Item 2	Bargraph
Item 3	Gross
Item 4	Digital I/O
Item 5	Tare
Item 6	Limits
Item 7	Date
Item 8	Analog output
Item 9	Time
Item 10	IP-address
Default	

The first line cannot be changed.

Possible settings, see Chapter [3.4.3.3](#).

7.15.8 Configuring limit values**Note:**

This menu item is only available if under -[Operating parameter]- [Application] "Standard" has been selected.

The parameters for limits are set under this menu item.

Each limit consists of a switch-on and a switch-off point for definition of a hysteresis. The 3 pairs of values must be entered according to the same principle. The limit values always refer to the gross weight. For the SPM addresses for the limits, see Chapter [13.4](#).

NOTICE

The limit values of an xBPI weighing point are scale-specific.

The scale must be active when entering the limit values.

- ▶ The scale and the unit must not be changed after configuration.
- ▶ The following settings are required: [Weighingpoint/xBPI-Scale] - [Setup] - [Configuration] - [Application settings] - [Number of units] "1 Weight"

Define the parameters for limits under -[Limit parameter].

Setup/Limit parameter		
Limit 1 on		0 kg
Limit 1 off	Action	-no action-
Limit 2 on		0 kg
Limit 2 off	Action	-no action-
Limit 3 on		0 kg
Limit 3 off	Action	-no action-

For the configuration the following order must be followed:

1. Define limits.
2. Define an action.
3. Determine a condition.
4. Save parameters.

7.15.8.1 Defining limits

Example 1:

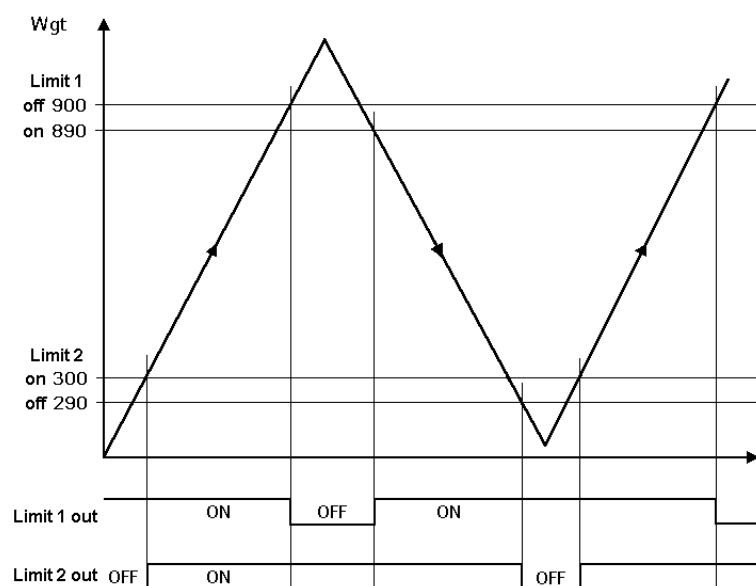

The output signal (Limit 1 out) of limit 1 switches OFF above a weight (Wgt) of 900 kg.
 The output signal (Limit 2 out) of Limit 2 switches OFF below 290 kg.

The two limit values have a hysteresis of 10 kg.

In the event of a power failure both outputs turn to "off" ("OFF"), thus indicating underfill and overfill simultaneously.

Example 2:

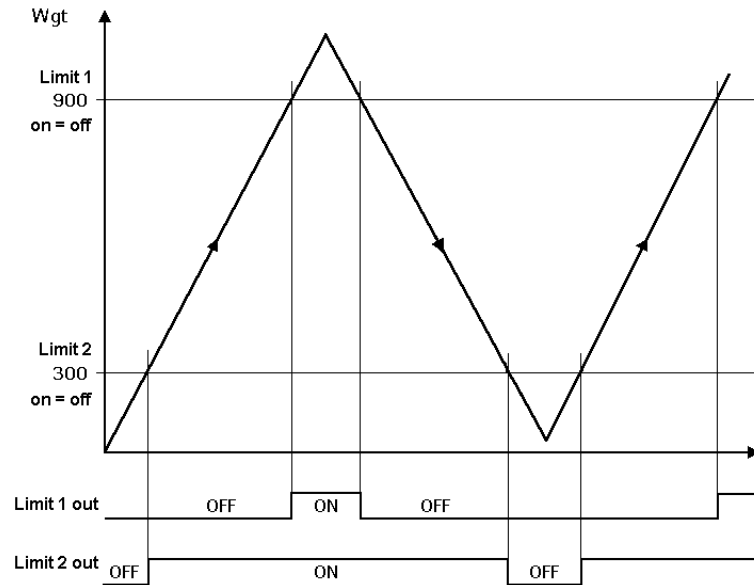

If the Limits 1 and 2 are the same for "On" and "Off" (on = off),

- switches output 1 (Limit 1 out) ON if the weight (Wgt) exceeds the value.
- switches output 2 (Limit 2 out) OFF if the weight falls below the value.

Setup/Limit parameter		
Limit 1 on		900 kg
Limit 1 off	Action	-no action-
Limit 2 on		300 kg
Limit 2 off	Action	-no action-
Limit 3 on		0 kg
Limit 3 off	Action	-no action-

1. Select the appropriate lines.
2. Use the keypad to enter and confirm the desired values (in this case: see Example 2).

7.15.8.2 Defining an action

The possible actions are listed in the following table.

Selection list for the actions [Action]

Function	SPM Bit	Description
-no action-	---	no function
set marker 1	X64 = 1	Set marker 1

Function	SPM Bit	Description
set marker 2	X65 = 1	Set marker 2
set marker 3	X66 = 1	Set marker 3
clr marker 1	X64 = 0	Clear marker 1
clr marker 2	X65 = 0	Clear marker 2
clr marker 3	X66 = 0	Clear marker 3

Note:

The limit values can be assigned to the outputs directly in the I/O parameters.

Markers can be set for all limits (in this case, see Example 2):

Setup/Limit parameter		
Limit 1 on		900 kg
	Action ↕	-no action-
Limit 1 off		900 kg
	Action	-no action-
Limit 2 on		300 kg
	Action	-no action-
Limit 2 off		300 kg
	Action	-no action-
Limit 3 on		0 kg
	Action	-no action-
Limit 3 off		0 kg
	Action	-no action-

1. Highlight and confirm the action line of the appropriate limit using the cursor.
 - ▷ A selection window opens.

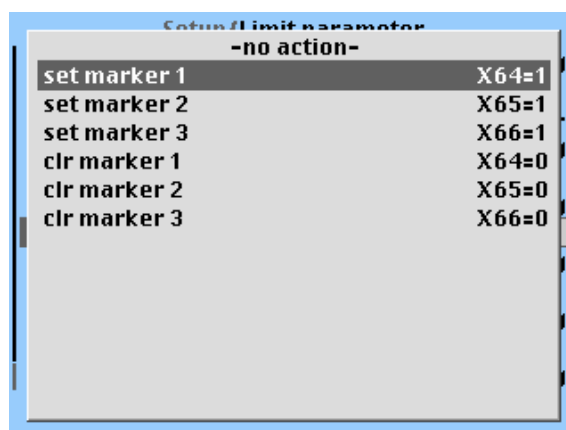

2. Select and confirm the appropriate line to set the marker for the corresponding limit (in this case, Marker 1 is set when 900 g is exceeded).
3. If applicable, set additional markers and confirm.

7.15.8.3 Determining a condition

Additionally, a [Condition] can be assigned to the marker.

The possible conditions are listed in the following table.

Selection list for [conditions]

Function	SPM Bit	Description
no condition	---	No condition
actual diginp1	X00 = 0	digital input 1: not active
actual diginp2	X01 = 0	digital input 2: not active
actual diginp3	X02 = 0	digital input 3: not active
actual limit 1	X16 = 0	Limiting signal 1: not active
actual limit 2	X17 = 0	Limiting signal 2: not active
actual limit 3	X18 = 0	Limiting signal 3: not active
ADC error	X32 = 0	General error in weighing point: not active (no error)
above Max	X33 = 0	Weight above Max: not active
overload	X34 = 0	Weight above Max plus the 'overload' value: not active
below zero	X35 = 0	Weight not below zero
center zero	X36 = 0	Weight not within $\frac{1}{4}$ d of zero
inside ZSR	X37 = 0	Weight not within zero-setting range
standstill	X38 = 0	Standstill not active
out	X39 = 0	Weight not below zero or above Max
command error	X48 = 0	For internal use only.
command busy	X49 = 0	For internal use only.
power fail	X50 = 0	Set after power-on (=power failure): not active
test active	X56 = 0	Analog test was not started.
cal active	X57 = 0	For internal use only.
tare active	X58 = 0	Instrument is not tared.
marker bit 1	X64 = 0	Marker bit 1 not set, after power-on the markers are set to "0".
marker bit 2	X65 = 0	Marker bit 2 not set, after power-on the markers are set to "0".
marker bit 3	X66 = 0	Marker bit 3 not set, after power-on the markers are set to "0".
actual diginp1	X00 = 1	digital input 1: active
actual diginp2	X01 = 1	digital input 2: active
actual diginp3	X02 = 1	digital input 3: active
actual limit 1	X16 = 1	Limiting signal 1: active
actual limit 2	X17 = 1	Limiting signal 2: active
actual limit 3	X18 = 1	Limiting signal 3: active

Function	SPM Bit	Description
ADC error	X32 = 1	General error in the weighing point
above Max	X33 = 1	Weight above Max
overload	X34 = 1	Weight above Max plus the 'overload' value
below zero	X35 = 1	Weight below zero
center zero	X36 = 1	Weight within ¼ d of zero
inside ZSR	X37 = 1	Weight within zero-setting range
standstill	X38 = 1	Standstill is active
out	X39 = 1	Weight below zero or above Max
command error	X48 = 1	For internal use only.
command busy	X49 = 1	For internal use only.
power fail	X50 = 1	Set after power-on (=power failure)
test active	X56 = 1	Analog test was started.
cal active	X57 = 1	For internal use only.
tare active	X58 = 1	Instrument is tared.
marker bit 1	X64 = 1	Marker bit 1 set, after power-on the markers are set to "0".
marker bit 2	X65 = 1	Marker bit 2 set, after power-on the markers are set to "0".
marker bit 3	X66 = 1	Marker bit 3 set, after power-on the markers are set to "0".

Setup/Limit parameter			
Limit 1 on			900 kg
	Action	set marker 1	X64=1
	Condition	no condition	-----
Limit 1 off			900 kg
	Action	-no action-	
Limit 2 on			300 kg
	Action	-no action-	
Limit 2 off			300 kg
	Action	-no action-	
Limit 3 on			0 kg
	Action	-no action-	
Limit 3 off			0 kg

1. Highlight and confirm the condition line of the appropriate limit using the cursor.
 - ▷ A selection window opens.

act. diginp 1	X00=1
act. diginp 2	X01=1
act. diginp 3	X02=1
limit 1 out	X16=1
limit 2 out	X17=1
limit 3 out	X18=1
ADU error	X32=1
above MAX	X33=1
overload	X34=1
below zero	X35=1
center zero	X36=1
inside ZSR	X37=1
standstill	X38=1

2. Select and confirm the appropriate line (here: Standstill is active).
3. If applicable, select additional conditions for the other limits and confirm.

7.15.8.4 Saving parameters

- ▶ Press the  softkey to exit the menu.

7.15.9 Configuring digital inputs

An action both for signal change from 0 to 1 (on) and from 1 to 0 (off) can be determined for each of the three inputs.

Digital inputs can be linked with conditions that must be met before an action can be started.

The parameters for the digital inputs are defined under -[Digital i/o parameter].

Note:

This menu item is only available if under -[Operating parameter]- [Application] "Standard" has been selected.

Output 1	↕marker bit 1	X64=1
Output 2	marker bit 2	X65=1
Output 3	marker bit 3	X66=1
Input 1 on	-no action-	
Input 1 off	-no action-	
Input 2 on	-no action-	
Input 2 off	-no action-	
Input 3 on	-no action-	
Input 3 off	-no action-	

For the configuration the following order must be followed:

1. Defining an action
2. Determining a condition
3. Saving parameters

7.15.9.1 Defining an action

The possible actions are listed in the following table.

Selection list for actions of the inputs [Input 1/2/3 on/off]

Function	SPM Bit	Description
-no action-	---	no function
set marker 1	X64 = 1	Set marker 1
set marker 2	X65 = 1	Set marker 2
set marker 3	X66 = 1	Set marker 3
select net	X72 = 1	Select net
set zero	X112 = 1	Set zero
set tare	X113 = 1	Set tare
reset tare	X114 = 1	Reset tare
set test	X115 = 1	Activate the analog test
reset test	X116 = 1	Finish the analog test
reset PWF	X117 = 1	Reset power fail
set fixtare	X118 = 1	Set fixtare (use the value in address D31 as a tare value)
get fixtare	X119 = 1	Save gross value as fixtare in address D31
clr marker 1	X64 = 0	Clear marker 1
clr marker 2	X65 = 0	Clear marker 2
clr marker 3	X66 = 0	Clear marker 3
select gross	X72 = 0	Save the gross weight in address D11

Actions can be selected (bits set) for all digital inputs (see table).

Setup/Digital i/o parameter		
Output 1	marker bit 1	X64=1
Output 2	marker bit 2	X65=1
Output 3	marker bit 3	X66=1
Input 1 on	↕	-no action-
Input 1 off		-no action-
Input 2 on		-no action-
Input 2 off		-no action-
Input 3 on		-no action-
Input 3 off		-no action-

1. Select the appropriate line using the cursor (here: Input 1 on) and confirm.

Define the action for the rising edge of Input 1 (in this case: When the input signal changes from 0 to 1, a tare command is generated).

Accordingly, an action for the falling edge can be determined.

- ▷ A selection window opens.

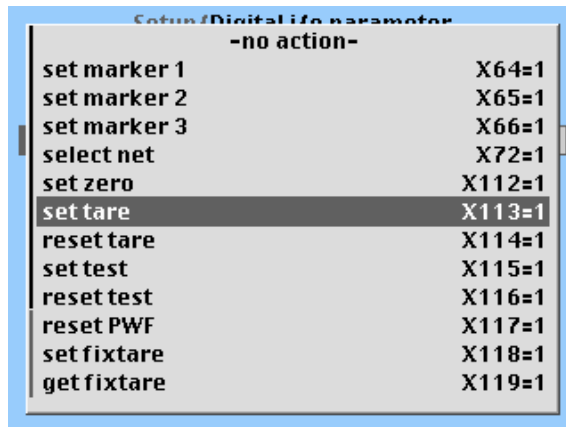

2. Select and confirm the appropriate line.
3. If applicable, select additional actions (setting bits) and confirm.

7.15.9.2 Determining a condition

The selected action of each digital input can be combined with a condition that must be met for signal change from 0 to 1 (on) or for signal change from 1 to 0 (off). The condition is selected from the list in Chapter 7.15.8.3.

No condition is defined when selecting [no condition]. The action is executed directly.

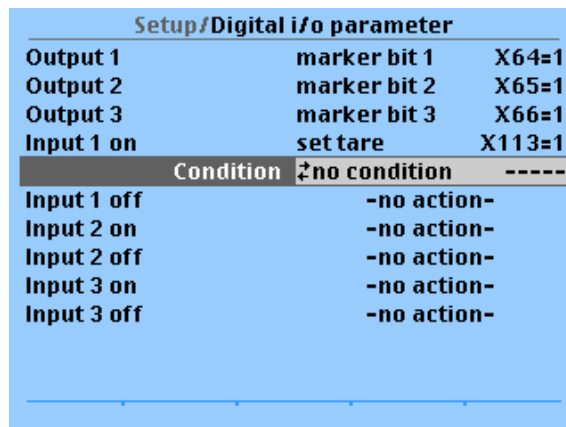

1. Select and confirm the condition line of the appropriate parameter.
 - ▷ A selection window opens.

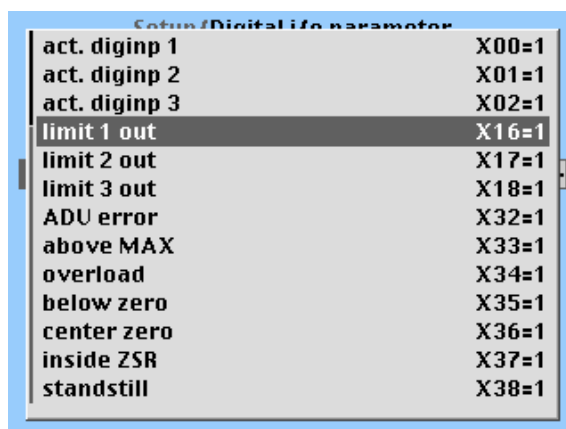

2. Select and confirm the appropriate line (here: If input 1 changes from 0 to 1 [Input 1 on], a taring signal is triggered only, if the condition under [Condition] is met (limit 1 out = active).
3. If applicable, select additional conditions for the other parameter and confirm.

7.15.9.3 Saving parameters

- ▶ Press the  softkey to exit the menu.

7.15.10 Configuring digital outputs

Configure the required function for [Output 1] to [Output 3] by selecting a signal from the list.

The output is set to the corresponding state.

Selection list for output functions

Function	SPM Bit	Description
no condition	---	No condition
actual diginp1	X00 = 0	digital input 1: not active
actual diginp2	X01 = 0	digital input 2: not active
actual diginp3	X02 = 0	digital input 3: not active
limit 1 out	X16 = 0	Limiting signal 1: not active
limit 2 out	X17 = 0	Limiting signal 2: not active
limit 3 out	X18 = 0	Limiting signal 3: not active
ADC error	X32 = 0	General error in weighing point: not active (no error)
above Max	X33 = 0	Weight above Max: not active
overload	X34 = 0	Weight above Max plus the 'overload' value: not active
below zero	X35 = 0	Weight not below zero
center zero	X36 = 0	Weight not within ¼ d of zero
inside ZSR	X37 = 0	Weight not within zero-setting range
standstill	X38 = 0	Standstill not active
out (of range)	X39 = 0	Weight not below zero or above Max
command error	X48 = 0	For internal use only.
command busy	X49 = 0	For internal use only.
power fail	X50 = 0	Set after power-on (=power failure): not active
test active	X56 = 0	Analog test was not started.
cal active	X57 = 0	For internal use only.
tare active	X58 = 0	Instrument is not tared.
marker bit 1	X64 = 0	Marker bit 1 not set, after power-on the markers are set to "0".

Function	SPM Bit	Description
marker bit 2	X65 = 0	Marker bit 2 not set, after power-on the markers are set to "0".
marker bit 3	X66 = 0	Marker bit 3 not set, after power-on the markers are set to "0".
actual diginp1	X00 = 1	digital input 1: active
actual diginp2	X01 = 1	digital input 2: active
actual diginp3	X02 = 1	digital input 3: active
limit 1 out	X16 = 1	Limiting signal 1: active
limit 2 out	X17 = 1	Limiting signal 2: active
limit 3 out	X18 = 1	Limiting signal 3: active
ADC error	X32 = 1	General error in the weighing point
above Max	X33 = 1	Weight above Max
overload	X34 = 1	Weight above Max plus the 'overload' value
below zero	X35 = 1	Weight below zero
center zero	X36 = 1	Weight within ¼ d of zero
inside ZSR	X37 = 1	Weight within zero-setting range
standstill	X38 = 1	Standstill is active
out (of range)	X39 = 1	Weight below zero or above Max
command error	X48 = 1	For internal use only.
command busy	X49 = 1	For internal use only.
power fail	X50 = 1	Set after power-on (=power failure)
test active	X56 = 1	Analog test was started.
cal active	X57 = 1	For internal use only.
tare active	X58 = 1	Instrument is tared.
marker bit 1	X64 = 1	Marker bit 1 set, after power-on the markers are set to "0".
marker bit 2	X65 = 1	Marker bit 2 set, after power-on the markers are set to "0".
marker bit 3	X66 = 1	Marker bit 3 set, after power-on the markers are set to "0".

Example: [overload] function

SPM Bit [X34 = 1]

Function and output are active (e.g.: if 'overload' is reached, a lamp is lit).

SPM Bit [X34 = 0]

Function is active and output is not active (e.g.: if "overload" is reached, a lamp goes out).

The parameters for the digital outputs are defined under -[Digital i/o parameter].

Note:

This menu item is only available if under -[Operating parameter]- [Application] "Standard" has been selected.

Example:

Setup/Digital i/o parameter		
Output 1	marker bit 1	X64=1
Output 2	marker bit 2	X65=1
Output 3	marker bit 3	X66=1
Input 1 on	-no action-	
Input 1 off	-no action-	
Input 2 on	-no action-	
Input 2 off	-no action-	
Input 3 on	-no action-	
Input 3 off	-no action-	

1. Select [Output 1] and confirm.
 - ▷ A selection window opens.

Setup/Digital i/o parameter		
act. diginp 1		X00=1
act. diginp 2		X01=1
act. diginp 3		X02=1
limit 1 out		X16=1
limit 2 out		X17=1
limit 3 out		X18=1
ADU error		X32=1
above MAX		X33=1
overload		X34=1
below zero		X35=1
center zero		X36=1
inside ZSR		X37=1
standstill		X38=1

The output 1 [Output 1] is true (active), when the weight value drops below zero (X35=1).

2. Select [below zero] and confirm.
3. Select [Output 2] and confirm.

- ▷ A selection window opens.



Output 2 [Output 2] remains (active), as long as the weight is not above Max (X33=0).

4. Select [above MAX] and confirm.
5. Select [Output 3] and confirm.
- ▷ A selection window opens.



Output 3 [Output 3] is true (active), when the weight is zero $\pm 1/4$ d (X36=1).

6. Select [center zero] and confirm.
- ▷ The menu opens.

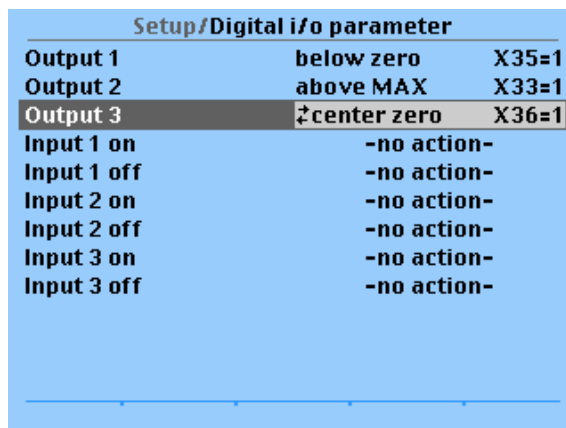

7. Press to exit the menu and save.

7.15.11 Display of limits and digital inputs/outputs

7.15.11.1 VNC display

Info/HW-Slots	
Builtin	digital i/o
In use by PLC task	1
Digital Outputs	000
Digital Inputs	000

Stop PLC Stop i/o

The status is indicated from right to left.

7.15.11.2 Device display

+ 01.593 kg	
B	+01.593kg Inputs: <input type="checkbox"/> <input type="checkbox"/> <input type="checkbox"/>
T	00.000kg Outputs: <input checked="" type="checkbox"/> <input type="checkbox"/> <input type="checkbox"/>
2003-07-17	Limits: <input checked="" type="checkbox"/> <input checked="" type="checkbox"/> <input checked="" type="checkbox"/>
13:14:37	Ana: 24.000mA

The status is indicated from left to right.

7.15.12 Configuring analog output

The weight value of the weighing point is transmitted to the output.

Define the parameters for the analog output under -[Analog output parameter].

Setup/Analog output parameter	
Analog mode	↕ no output
Analog range	0..20mA
Output on error	0mA
Output if < 0	0mA
Output if > Max	0mA
Weight at 0/4mA	0 kg
Weight at 20mA	3000 kg

The analog output can be configured according to the table below.

Parameter table

Menu item	Selection	Description
[Analog mode]	[no output]	Analog output is unused.
	[Gross D08]	Output of the gross weight.
	[Net if tared D09]	Output of the net weight, if tared; otherwise gross weight
	[Selected D11]	Output of the gross/net value on the display, dependent on SPM bit X72.
	[Transparent D30]	Output of the value in D30
[Analog range]	[0...20 mA]	Output of 0...20 mA.
	[4...20 mA]	Output of 4...20 mA.
[Output on error]	[0 mA]	Set output to 0 mA.
	[4 mA]	Set output to 4 mA.
	[20 mA]	Set output to 20 mA.
	[hold]	The last output value is held.
[Output if < 0]	[0 mA]	Set output to 0 mA.
	[4 mA]	Set output to 4 mA.
	[20 mA]	Set output to 20 mA.
	[linear]	The output drops below 4 mA down to the limit (at 4...20 mA).
[Output if > Max]	[0 mA]	Set output to 0 mA.
	[4 mA]	Set output to 4 mA.
	[20 mA]	Set output to 20 mA.
	[linear]	Output increases above 20 mA until the limit is reached.
[Weight at 0/4 mA]		Weight value for 0/4 mA output.
[Weight at 20 mA]		Weight value for 20 mA output.

Quit the menu and save parameters by pressing .

Note:

Adapting the analog output, see Chapter [9.1.2.1](#).

7.16 System information

This menu displays system information.

You can also check inputs and outputs, see Chapter [9.1.2.2](#).

- ▶ Press  to access the menu.

Note:

 also has other functions; see Chapters [7.12.2.2](#) and [7.12.10](#).

7.16.1 Displaying the version

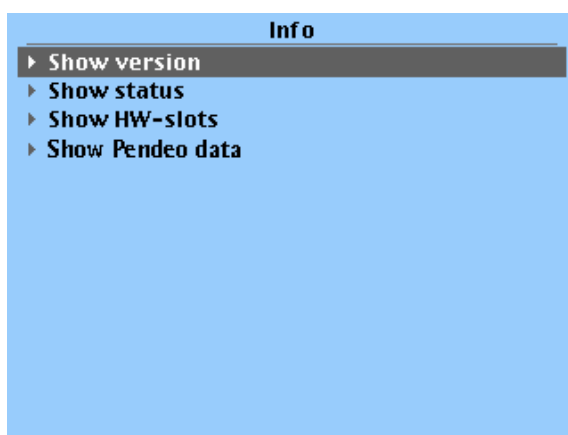

1. Confirm [Show version].

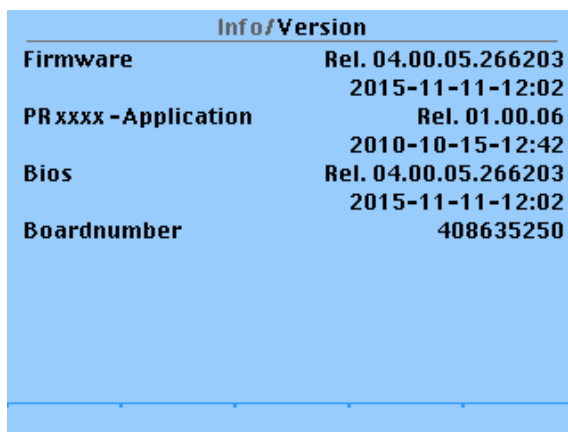

- ▷ This line shows the following information:
 - [Firmware]**
Version number and firmware creation date
 - [PRxxx-Application]**
Version number and application creation date

[BIOS]

Version number and BIOS creation date

[Board number]

Nine-digit board number

2. Press **Exit** to return to the previous window.

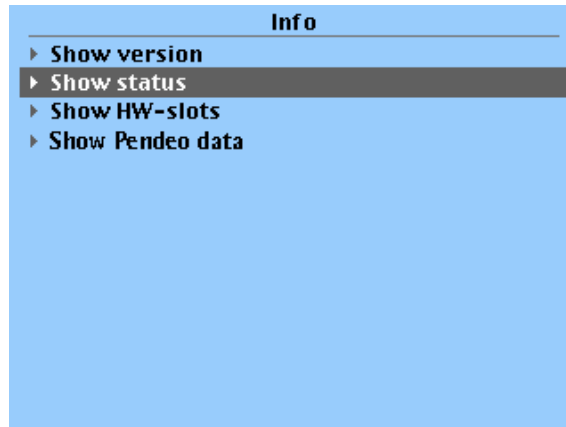
7.16.2 Displaying the status

1. Select [Show status].

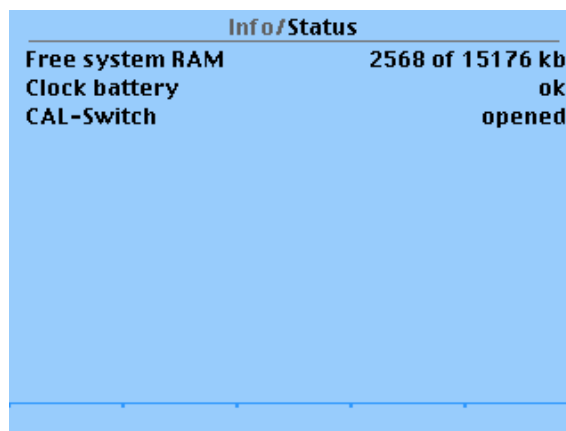

- ▷ This line shows the following device statuses:

[Free system RAM]

Free working system memory space

[Clock battery]

Status display

ok = voltage OK

low = voltage too low

[CAL switch]

Status display

[opened] = opened, no write protection.

[closed] = closed, write protection is active.

2. Press  to return to the previous window.

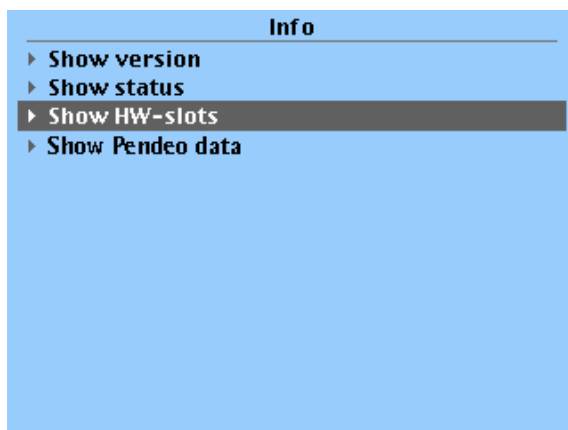
7.16.3 Showing hardware options

1. Select [Show HW-slots] and confirm.

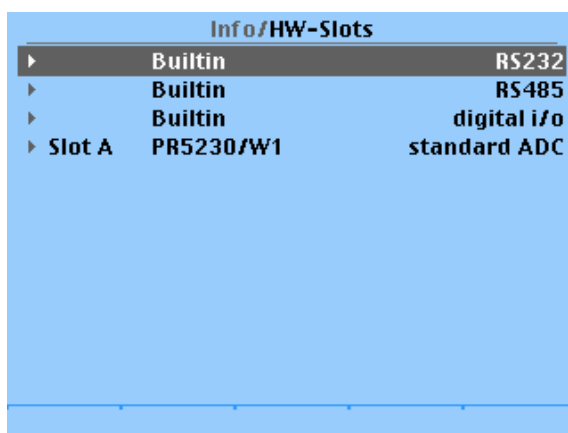

- ▷ This line shows the following device statuses:

1st line

Standard interface, serial

2nd line

Standard interface, analog outputs

3rd line

Standard interface, digital I/Os

4th line

Slot A, weighing electronics

The tool tip displays the weighing point serial number and manufacturing date of the factory.

2. Press  to return to the previous window.

7.16.4 Displaying Pendeo data

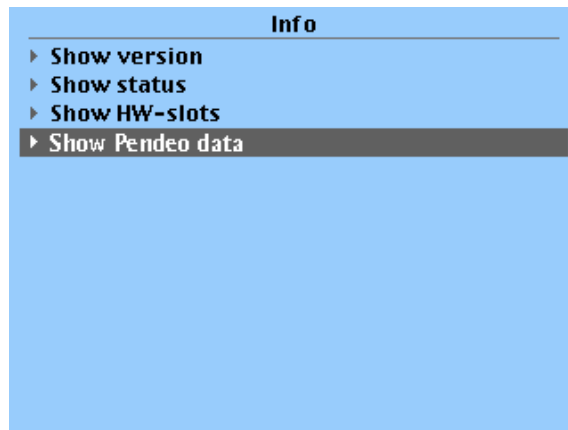

1. Select [Show Pendeo data] and confirm.

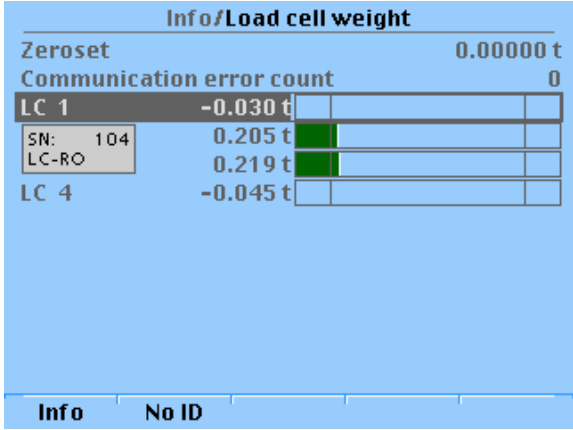

The screenshot shows a window titled 'Info/Load cell weight' with the following data:

Info/Load cell weight	
Zeraset	0.00000 t
Communication error count	0
LC 1	-0.030 t
SN: 104	0.205 t
LC-RO	0.219 t
LC 4	-0.045 t

At the bottom of the window, there are two buttons: 'Info' and 'No ID'.

- ▷ An info window opens.

[Zero correction] (zero point correction)

The zero point correction in use is displayed.

[Communication error count] (communication error counter)

The communication errors (time frames exceeded) for the load cells are counted here in ascending order and displayed.

[LC 1...n]

Bar graph display

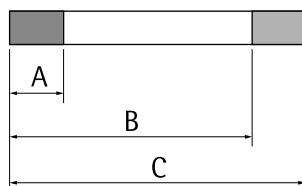

The bar graph shows three areas:

A

dead load (can be changed by calibration)

B

Maximum capacity E_{max} (max. capacity of load cell) including dead load (load cell, cannot be changed)

C

Max. load including dead load (load cell, cannot be changed)

The colors have the following meanings:

Red

Weight value is above maximum load (overload) or below $-1/4d$

Green

Weight value is within tolerances

Orange

Weight value is above maximum capacity E_{max} (max. capacity of load cell)

[No ID]

The Serial number is hidden.

[Show ID]

The Serial number is visible.

- Select the desired load cell and press the [Info] softkey.

▷ The load cell data is displayed:

Info/Load cell weight/Load cell info	
Model name	PR6204/53tC3
Software version	01.00.04
Loadcell serial number	101
E_{max}	5.0 t
n	3000 e
Y	14000
Z	3000
Overload	50.0 t
Overload counter	0
Temperature	17.4 °C
Max temperature	18.2 °C
Min. temperature	17.4 °C
Max. weight at	1999-11-30-00:07:42

Display	Description
Model name	e.g.: PR6204/50tC3
Software version	Software version of the load cell
Load cell serial number	Serial number of the load cell
E _{max}	Maximum capacity
n	Max. resolution
Y	Minimum LC verification
Z	Minimum preload signal recurrence
Overload	Weight value above max. load
Overload counter	Number of weight values above max. load The higher the number, the higher the probability of a faulty load cell.
Temperature	Current measured temperature
Max. temperature	Max. measured temperature
Min. temperature	Min. measured temperature
Max. weight value at	Date and time display Time of largest load on load cells
Max. weight value	Display
Firmware checksum	Display of the firmware checksum in HEX format Checksum about the installed firmware version
Config. checksum	Display of the config. checksum in HEX format Checksum about the memory area where the parameters that are relevant for calibration are stored.

3. Press  to return to the previous window.

8 Production

8.1 General notes

All filling functions are only supported by the "EasyFill" application.

NOTICE

Data is lost if the power is interrupted.

There are hard drives for 10 material data records available, which are retained after a power failure.

► It is important to save material data.

8.2 Starting the application

Requirements:

- The "EasyFill" application has been selected; see Chapter [7.15.3](#).

Procedure:

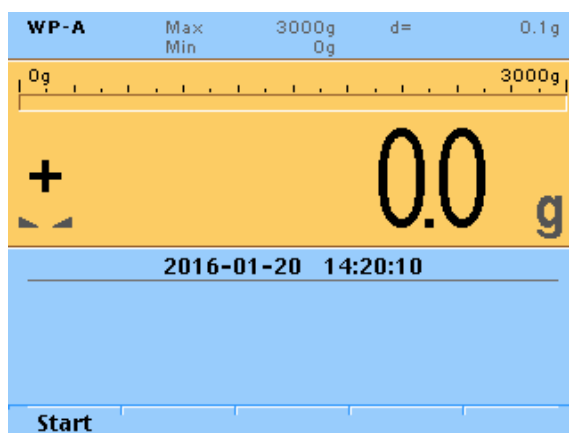

- Press the [Start] softkey.
 - ▷ The menu opens.

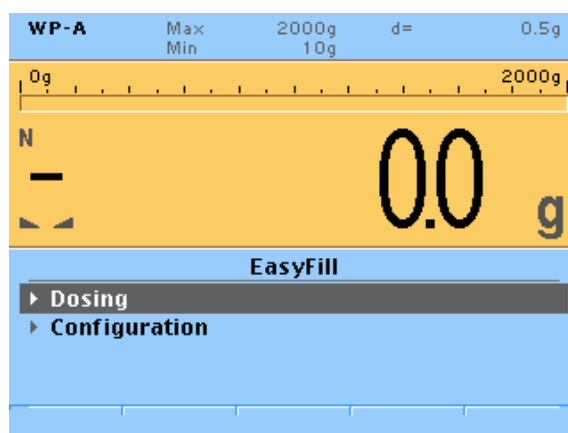

8.3 Configuration via a notebook/PC

8.3.1 Configuring production mode

The following modes are configured under the [Configuration mode] menu item:

- Filling mode
- Interaction mode

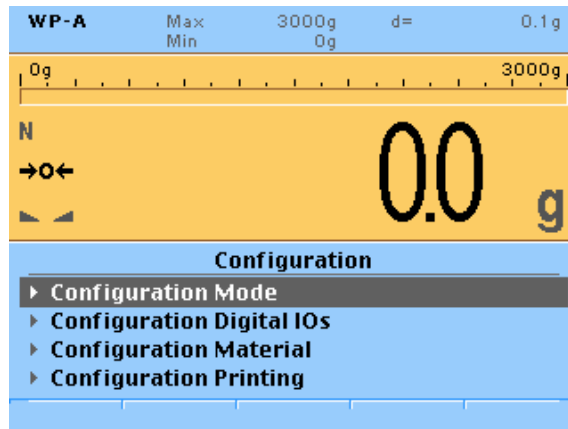

1. Select [Configuration mode] and confirm.

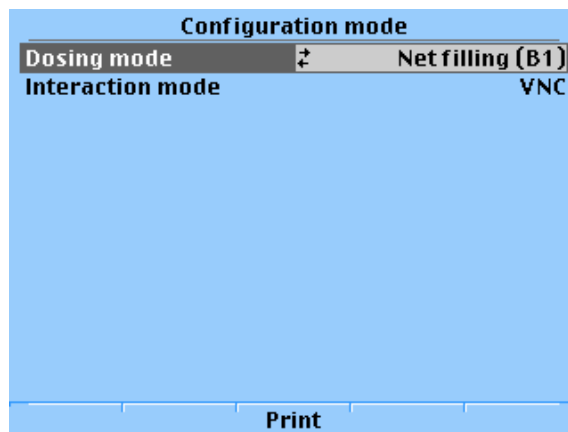

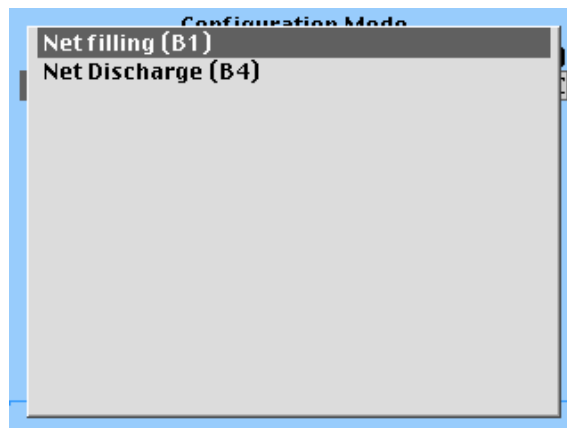

2. Select [Dosing mode] and confirm.
 - ▷ A selection window opens.

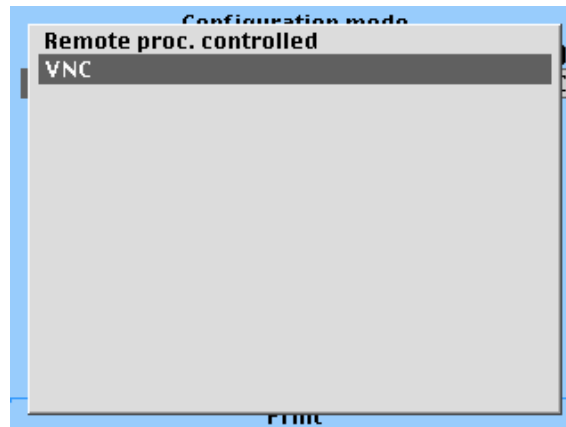

3. Select the desired filling mode (see Chapters [8.3.1.1](#) and [8.3.1.2](#)) and confirm.

4. Select [Interaction mode] and confirm.



5. Select the desired interaction mode (see Chapter [8.3.1.3](#)) and confirm.
6. Press  to exit the menu.
 - ▷ A prompt window opens.

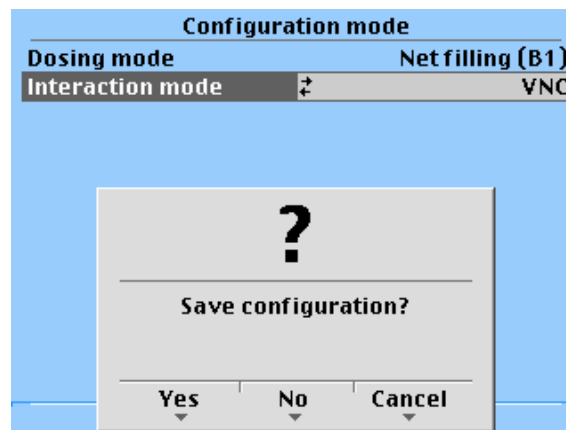

7. Press the [Yes] softkey to save the changes.

8.3.1.1 Net filling (B1)

The scale is tared and then the amount listed in the process line is automatically (Coarse/ Fine) added.

A fix overshoot value is configured.

Net = gross - tare

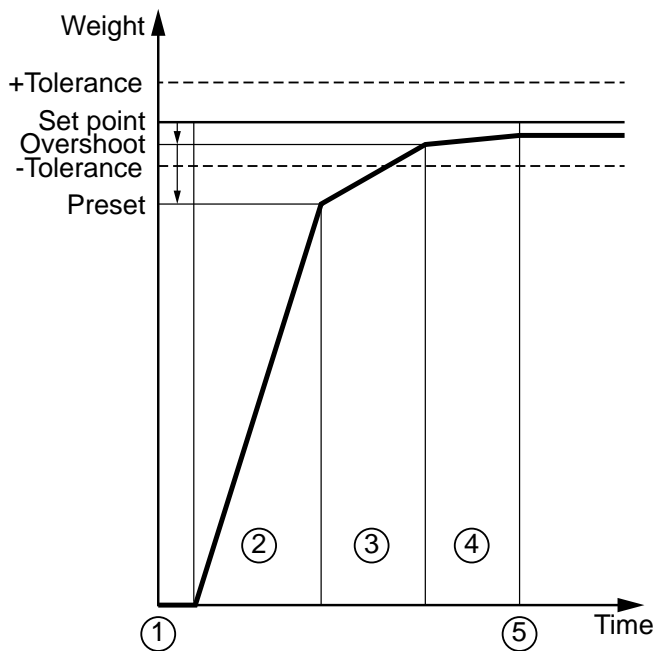
[Net filling] with dosing signals "Coarse/Fine" procedure

- ① Taring:
The current gross weight is saved as tare weight, and the net weight starts at zero.
- ② Coarse:
A coarse flow (coarse and fine) is batched until the preset is reached.
- ③ Fine:
A fine flow is batched until the switch-off point (overshoot) is reached.
- ④ Calming:
Time to wait during which the overshoot is effective and scale vibrations may settle.
- ⑤ Tolerance checking:
The weight is determined and checked against the tolerance values.

8.3.1.2 Net decrease (B4)

The scale is automatically discharged up to the specified value. The other parameters and the process correspond to the [Net filling] mode; see Chapter [8.3.1.1](#).

Net = gross - tare

Tare = gross

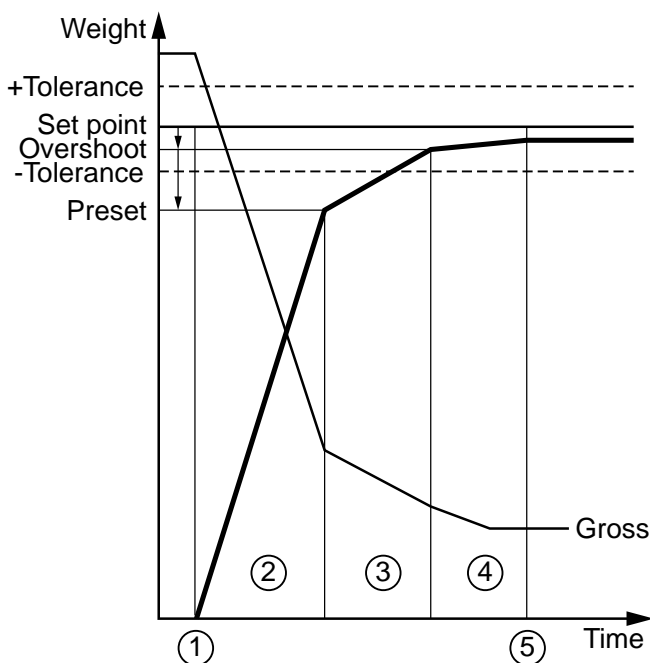
Sequence of [Net decrease] with dosing signals "coarse/fine"

- ① Taring:
The current gross weight is saved as the tare and the net weight starts at zero.
- ② Coarse:
A coarse flow (coarse and fine) is batched until the preset value is reached.
- ③ Fine:
A fine flow is batched until the switch-off point (overshoot) is reached.
- ④ Calming:
Time to wait during which the overshoot is effective and scale vibrations may settle.
- ⑤ Tolerance checking:
The weight is determined and checked against the tolerance values.

8.3.1.3 Interaction mode

You can choose between the following control/operating modes of the device in production:

- [Remote proc. control] via OPC/ModBus and/or fieldbus
- [VNC] (Virtual Network Computing)

The following table shows how individual modes are locked when production starts.

Starting production

Mode	VNC	Remote control OPC/ModBus	Remote control fieldbus	Digital inputs	Digital outputs
[Remote proc. control]		X	X	X	X
[VNC]	X				X

8.3.2 Configuring digital inputs and outputs

SPM addresses are assigned to the digital inputs and outputs under the [Configuration digital IOs] menu item.

Note:

The selected SPM address must be unique within the system.

The SPM addresses for the input and outputs are unchanged after a restart.

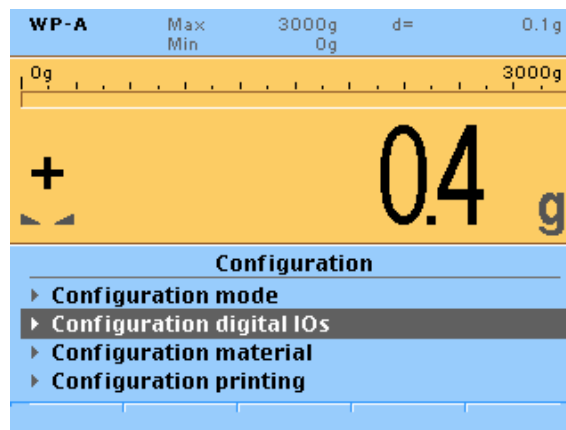

1. Select [Configuration digital IOs] and confirm.

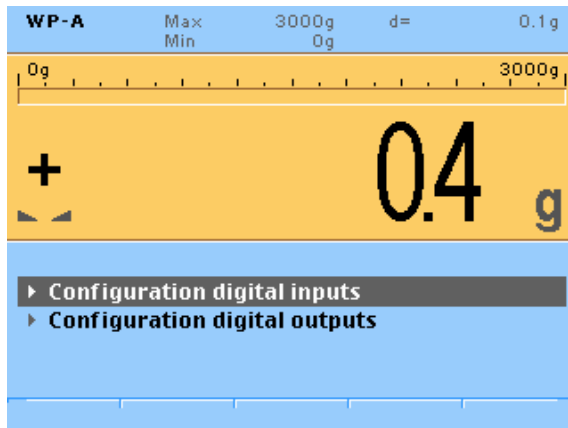

2. Select [Configuration digital inputs] and confirm.
 - ▷ The following window opens:

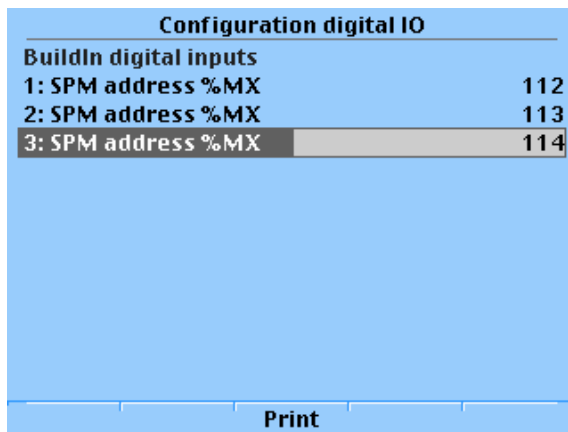

3. Select inputs 1...3. Use the keypad to enter and confirm a corresponding SPM address %MXxxx (see Chapter 13.4).

Note:

The SPM address %MX for an unused digital input = 0.

4. Press ^{Exit} to exit the window and to save the changes.

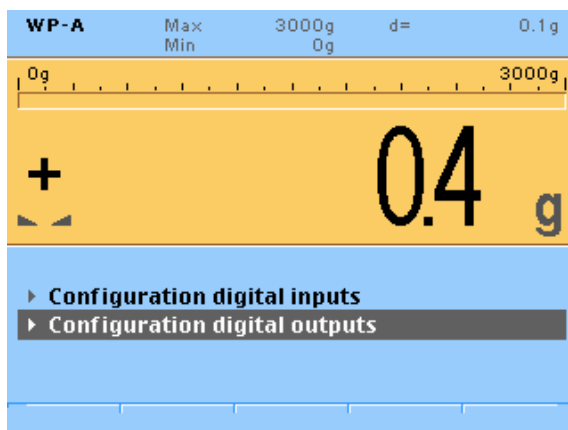

5. Select [Configuration digital outputs] and confirm.

- ▷ The following window opens:

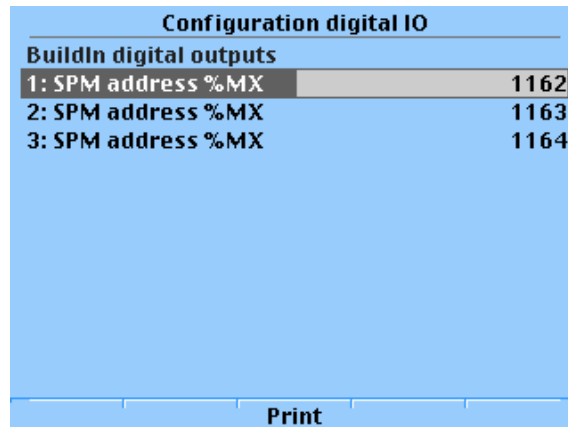

6. Select outputs 1...3. Use the keypad to enter and confirm a corresponding SPM address %MXxxx (see Chapter 13.4).

Note:

The SPM address %MX for an unused digital output = 0.

7. Press  to exit the window and to save the changes.

8.3.3 Configuring material

The materials (products) 1...10 are configured under the [Configuration material] menu item.

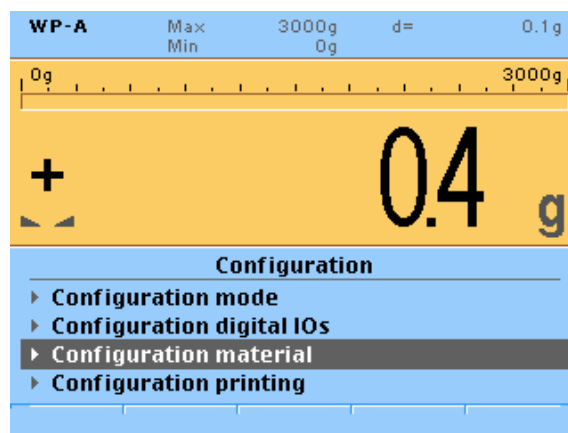

1. Select [Configuration material] and confirm.

- ▷ The configuration window appears.

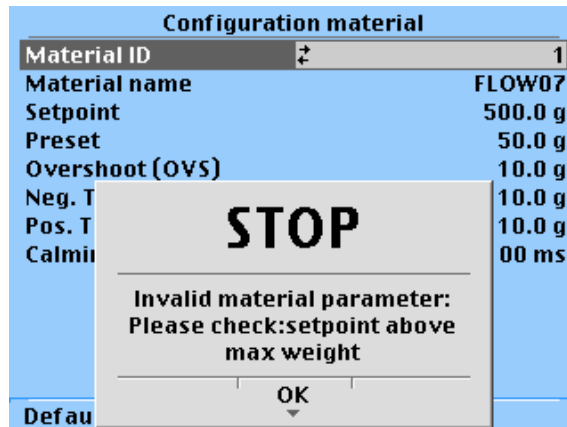

An error message appears if the parameters for the selected material do not match the parameters of the current calibration.

2. Press the [OK] softkey.
 3. Press the [Default] softkey.
- ▷ All values are reset.

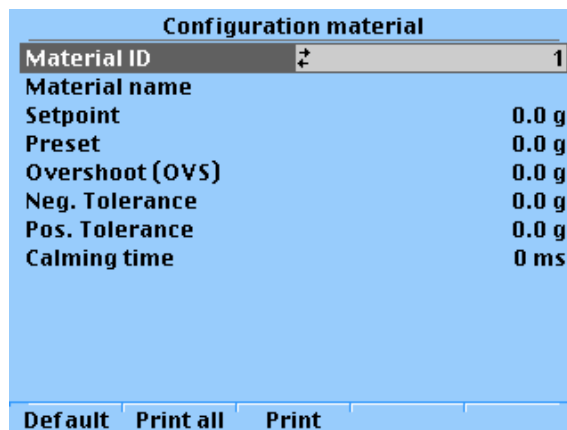

4. Enter the material name and values using the keypad and confirm.

[Material ID]

Material identification 1...10

[Material name]

Input: Material name, max. 18 alphanumeric characters

[Set point]

Input: Set point

[Preset]

Input: Preset point for switching from coarse flow to fine flow

[Overshoot (OVS)]

Input: Material overshoot

[+/- tolerance]

Input: Tolerance above/below set point

[Calming time]

Input: Calming time

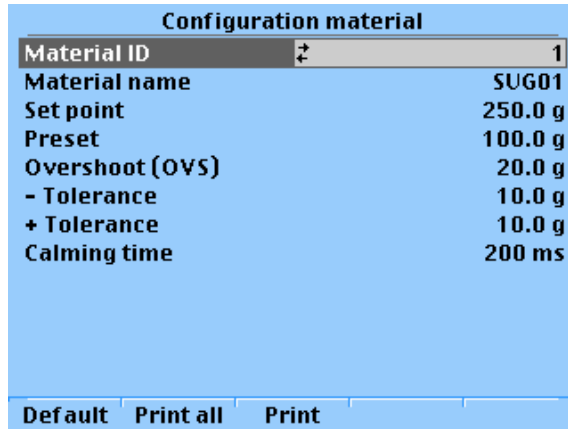

5. Configure additional materials if necessary.
6. Use the [Print all] or [Print] softkeys to print the configuration for the 10 materials or for the selected material.
7. Press  to exit the window.
 - ▷ A prompt window opens.

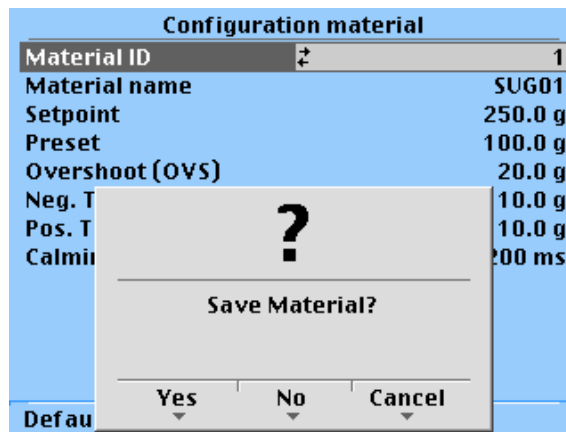

8. Press the [Yes] softkey to save the changes.

8.3.4 Configuring printout

The printout is configured under the [Configuration printing] menu item.

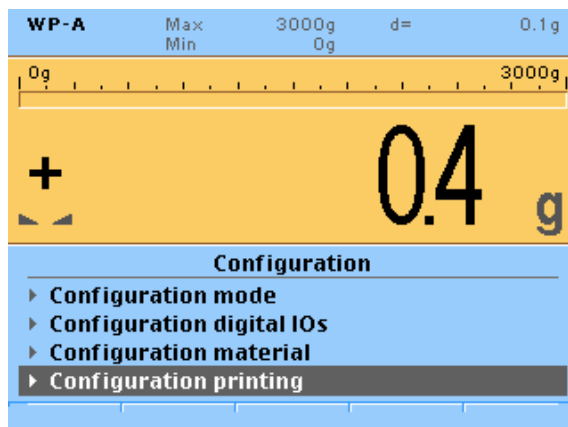

1. Select [Configuration printing] and confirm.
 - ▷ The configuration window appears.

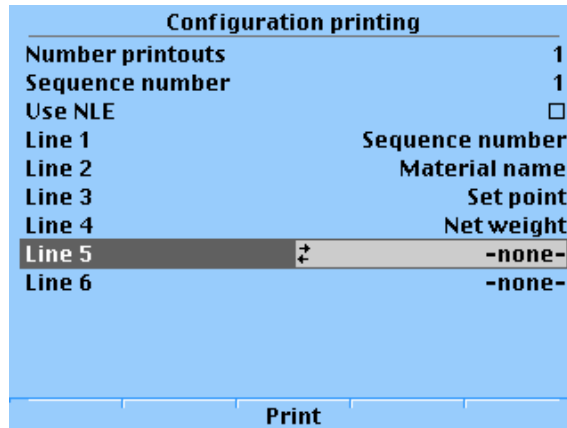

2. Select [Number printouts], enter the number of printouts between 1..10, and confirm.
3. Select [Sequence number], change the sequence number if necessary, and confirm.
4. Select [Use NLE]. Check the box to activate printing with NiceLabelExpress.
5. Select [Line 1]...[Line 6] and confirm.
 - ▷ A selection window opens.

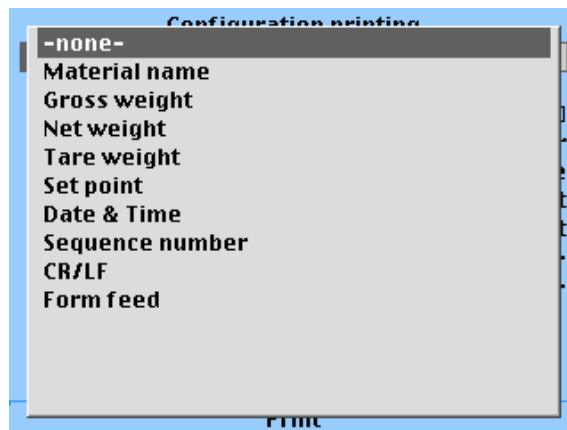

Selection: -none- (no printout; selected if fewer than 6 elements will be printed), Material name, Gross weight, Net weight, Tare weight, Set point, Date & Time (printed in format DD.MM.YYYY HH:MM:SS), Sequence number (counter for individual print orders, max. 6 digits, #000001 comes after #999999), CR/LF (carriage return and line feed), Form feed

6. Confirm selection.
7. Press the [Print] softkey to print out the configuration if necessary.
8. Press  to exit the window.

- ▷ A prompt window opens.

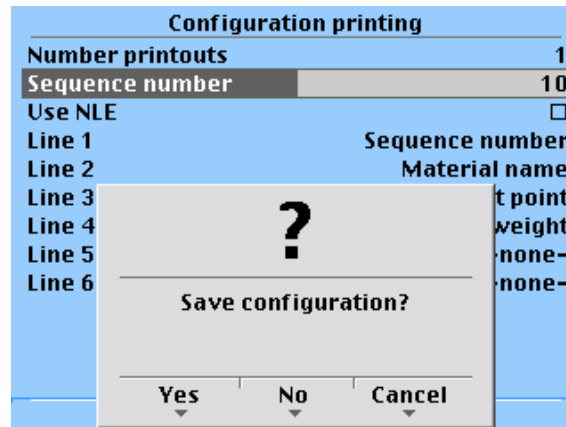

9. Press the [Yes] softkey to save the changes.

8.4 Filling

Requirements:

- Weighing point is calibrated.
- Production mode is configured; see Chapter [8.3.1](#).
- Digital inputs and outputs are configured (optional); see Chapter [8.3.2](#).
- Material (product) is configured; see Chapter [8.3.3](#).
- Printout is configured (optional); see Chapter [8.3.4](#).

Example:

- Filling mode: Net filling (B1)
- Interaction mode: VNC
- Digital outputs 1, 2: SPM-Adresse %MX 1162 (coarse)/1163 (fine)
- Material ID: 2

Procedure:

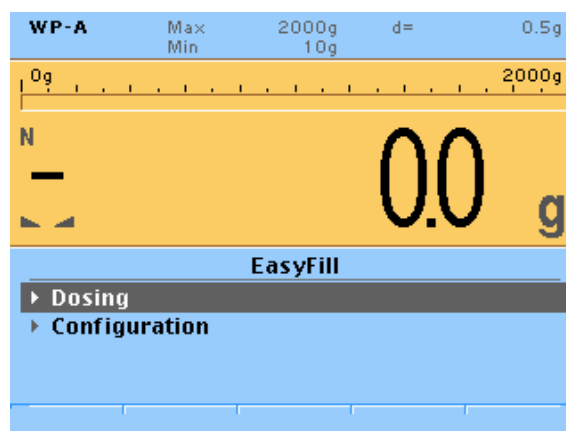

1. Select [Dosing] and confirm.

- ▷ The production window appears.

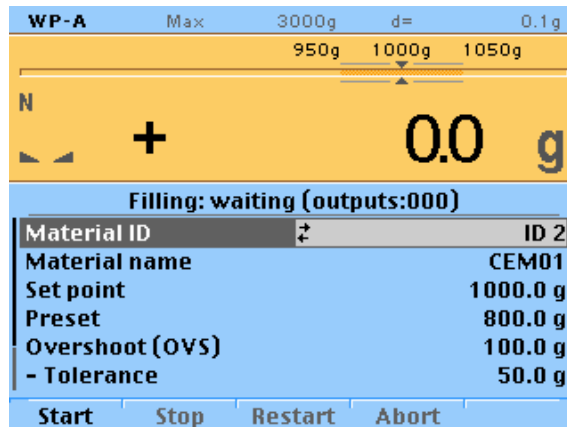

2. Select material ID [ID 2].
3. Press the [Start] softkey.
 - ▷ The material (product) is filled.
Press the [Stop] softkey to stop the process.
You can then press the [Restart] softkey to restart the process.
4. Once the set point is reached, the [Start] softkey can be pressed again.
5. Press Exit 2x to exit the application.

9 Extended functions

9.1 Hardware test

9.1.1 Serial interfaces

9.1.1.1 RS-232 interface

Open the menu with  - [HW-Slots].

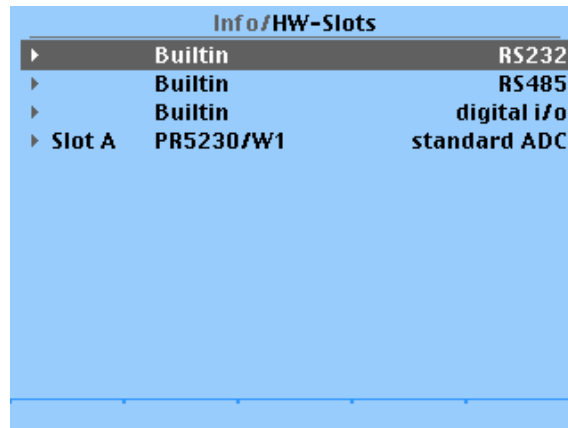

1. Plug the test connector (see Chapter [18.2](#)) into the RS-232 interface.
2. Select the interface and confirm.
 - ▷ The results are displayed:
 - passed = ok
 - failed (no data) = error

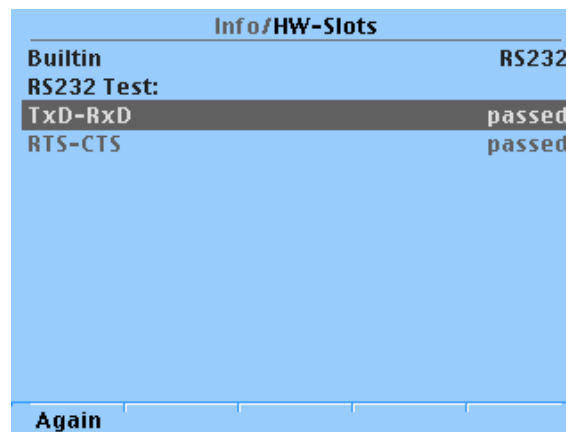

3. Press  to return to the previous window.

9.1.1.2 RS-485-interface

Open the menu with  - [HW-Slots].

Info/HW-Slots		
▶	Builtin	RS232
▶	Builtin	RS485
▶	Builtin	digital i/o
▶	Slot A	PR5230/W1 standard ADC

1. Plug the test connector (see Chapter 18.2) into the RS-485 interface.
2. Place the switch in the proper position, see Chapter 18.2.
3. Select and confirm the desired interface.
 - ▷ The results are displayed:
 - passed = ok
 - failed (no data) = error

Info/HW-Slots	
Builtin	RS485
RS485/RS422 Test:	
Send receive test	passed
Again	

Info/HW-Slots	
Builtin	RS485
RS485/RS422 Test:	
Send receive test	failed (nodata)
Again	

4. Press the  key to return to the previous window.

9.1.2 Inputs and outputs

There are different modes for testing the analog and digital inputs and outputs:

- Test mode "Monitor"
- Test mode "Internal"
- Test mode "External"

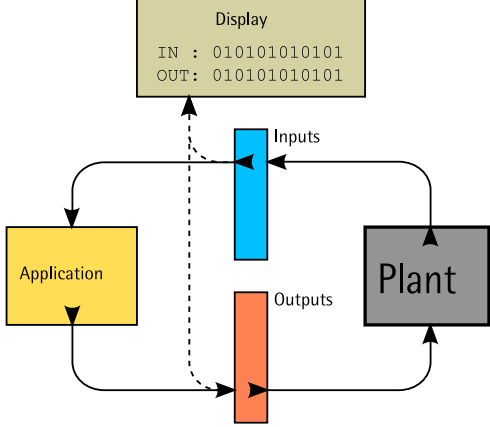
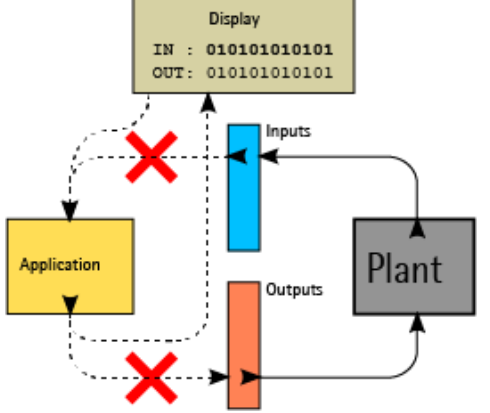
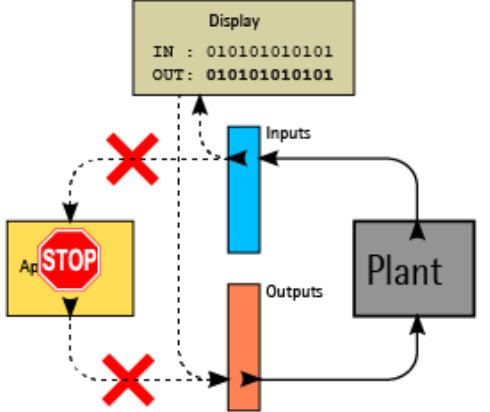
Test mode	Description
<p data-bbox="451 562 568 591">"Monitor"</p> 	<p data-bbox="975 562 1107 591">Active PLC:</p> <ul style="list-style-type: none"> - The physical inputs of the system (plant) are directed to the PLC (application). - The physical outputs of the system (plant) are set by the PLC (application). - The physical inputs and outputs are displayed (display).
<p data-bbox="451 1048 564 1077">"Internal"</p> 	<p data-bbox="975 1048 1107 1077">Active PLC:</p> <ul style="list-style-type: none"> - The entered input values are sent to the PLC (application). - The PLC output is displayed (display). - The physical inputs and outputs of the system (plant) are deactivated and passive (in secured condition).
<p data-bbox="451 1518 568 1547">"External"</p> 	<p data-bbox="975 1518 1171 1547">Deactivated PLC:</p> <ul style="list-style-type: none"> - The physical inputs are displayed (display). - Output values can be entered. - The given output values are set on the physical outputs.

9.1.2.1 Adapting the analog output

The output current can be adapted in small ranges. This is required, if small deviations from the nominal value occur in a connected PLC.

Open the menu with  - [HW-Slots].

Info/HW-Slots		
▶	Builtin	RS232
▶	Builtin	RS485
▶	Builtin	digital i/o
▶ Slot A	PR5230/W1	standard ADC

1. Select and confirm the analog output.

Info/HW-Slots	
Builtin	analog out
In use by PLC task	1
Analog output	10.245 mA
counts	27922 cnt

Stop PLC | Stop i/o | Adjust | Reset

2. Press the [Adjust] softkey.
 - ▷ The window for the 1st value opens.

Info/HW-Slots/Adjust Analog Output	
Output	4.000 mA
Measured	3.925 mA

3. Enter and confirm e.g. the value for 4 mA measured by the connected PLC under [Measured].

- ▷ The window for the 2nd value opens.

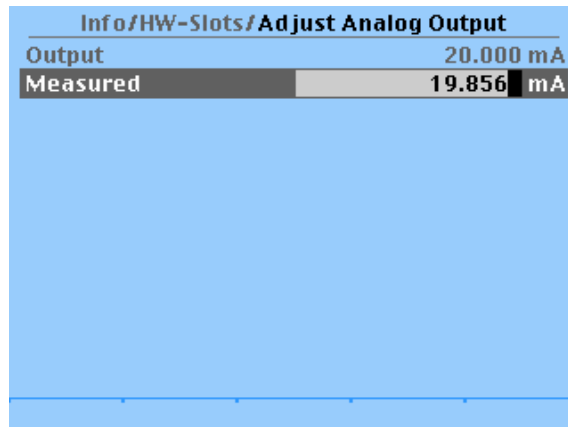

4. Enter and confirm e.g. the value for 20 mA measured by the connected PLC under [Measured].

- ▷ A prompt window opens.

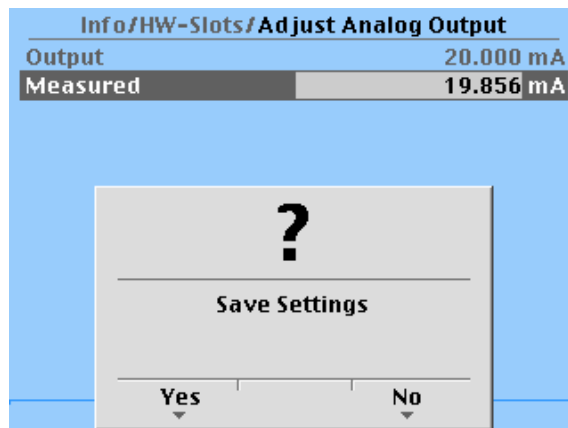

5. Press the [Yes] softkey to save the settings.

If applicable, press the [No] softkey to keep the original values.

- ▷ The following window opens:

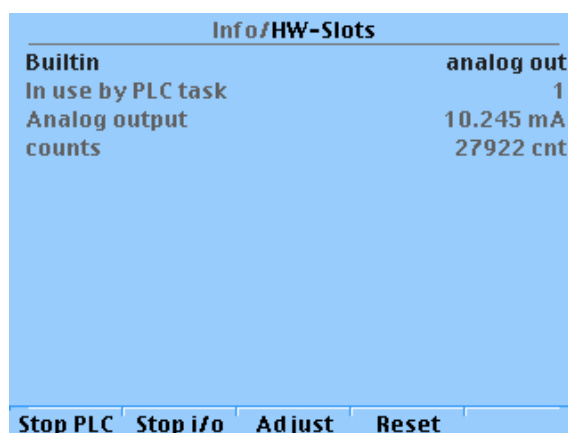

6. Press the [Reset] softkey to reset to the factory settings (4 mA and 20 mA).

- ▷ A prompt window opens.

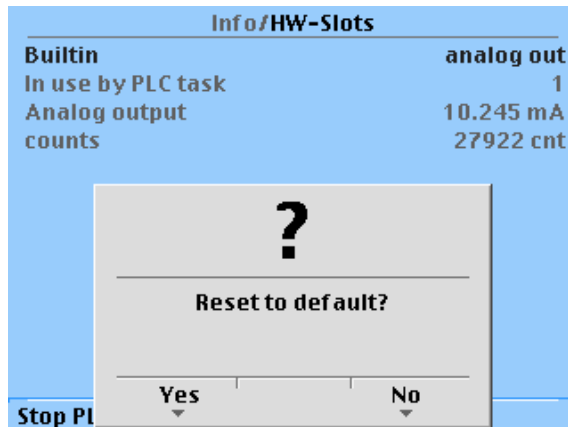

- Press the [Yes] softkey to reset to the factory settings.
If applicable, press the [No] softkey to keep the entered values.
- Press ^{Exit} to return to the previous window.

9.1.2.2 Digital inputs and outputs

Open the menu with ^{Info} - [HW-Slots].

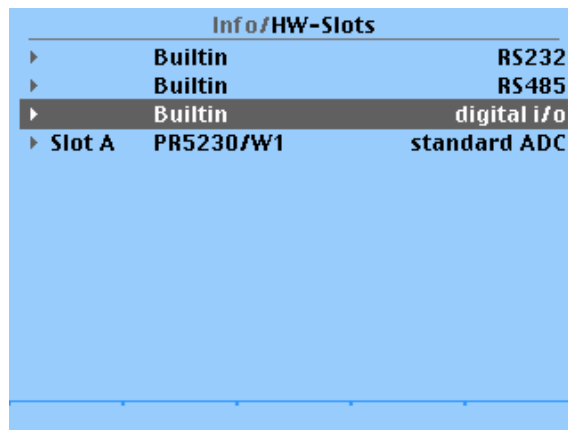

- Select and confirm the appropriate line.
▷ The following window opens.

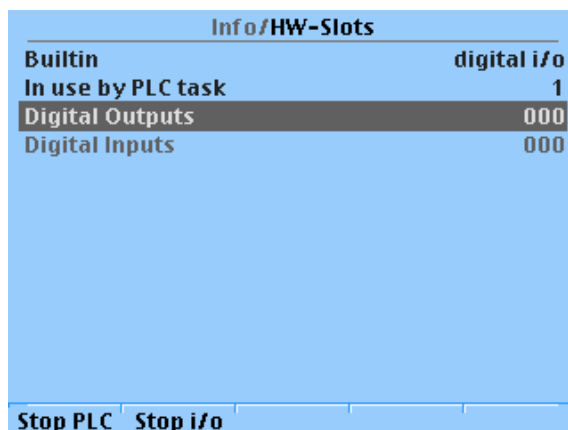

The "Monitor" test mode is active.

2. Press the [Stop i/o] softkey.

Info/HW-Slots	
Builtin	digital i/o
In use by PLC task	1
Digital Outputs	000
Digital Inputs	001

Stop PLC Run i/o

3. Enter the input values using the keyboard and confirm.

Input: 0 and 1 (e.g.: 111; 001)

- ▷ An info window is shown briefly. The "Internal" test mode is active.

The inputs are simulated to test the functionality of the PLC (application); see Chapter [9.1.2](#).

4. Press  to return to the previous window.
5. Press the [Stop PLC] softkey.

An info window is shown briefly.

Info/HW-Slots	
Builtin	digital i/o
In use by PLC task	0
Digital Outputs	100
Digital Inputs	000

Run PLC Stop i/o

6. Enter the output values using the keyboard and confirm.

Input: 0 and 1 (e.g.: 111; 100)

- ▷ An info window is shown briefly. The "External" test mode is active.

The physical inputs and outputs (hardware) are tested without the involvement of the PLC (application) (see Chapter [9.1.2](#)).

7. Press  to return to the previous window.

9.2 Functions via the WEB site

9.2.1 General information

If the device is connected to the network, it can be displayed e.g. in the "Windows" operating system under "Network".

Double-click the device icon to open the WEB menu (in English only) in the available Internet browser (see also Chapter [7.10](#)).

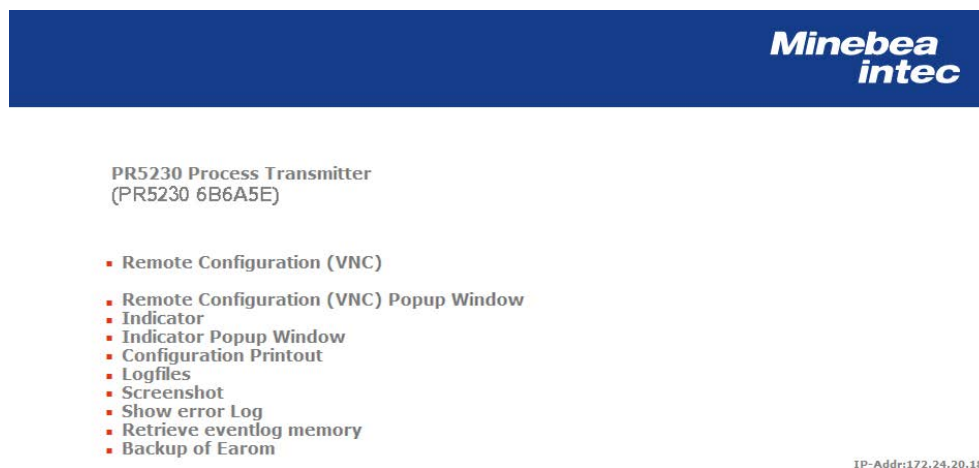

The device name entered under -[Network parameter]- [Hostname] is shown under the header in brackets.

[Indicator]

Displays the weighing point in a status window, see Chapter [9.2.2](#).

[Indicator pop-up window]

Displays the weighing point in a status window, see Chapter [9.2.2](#).

[Configuration printout]

Display configuration printout, saving and printing out as a text file, see Chapter [9.2.3](#).

[Log files]

Display logfiles, saving and printing out as a text file, see Chapter [9.2.4](#).

[Screenshot]

Displaying, saving and printing a screenshot, see Chapter [9.2.5](#).

[Show error Log]

Display and save the error logs, see Chapter [9.2.6](#).

[Retrieve eventlog memory]

This memory can be used to save events with a time stamp and to retrieve them, if necessary.

[Backup of Earom]

Saving and restoring the configuration and calibration data, see Chapter [9.2.8.1](#).

9.2.2 Displaying weighing points in a table

1. Click on the [Indicator] menu item in the WEB menu.

- ▷ A status window opens in which the weight of the weighing point is displayed with unit and the status symbols.

+ 1000.03 g

2. Click on the  symbol in the Internet browser to return to the WEB menu.
3. Click on the [Indicator Pop-up Window] menu item in the WEB menu.
 - ▷ A separate status window opens in which the weight of the weighing point is displayed with unit and the status symbols.

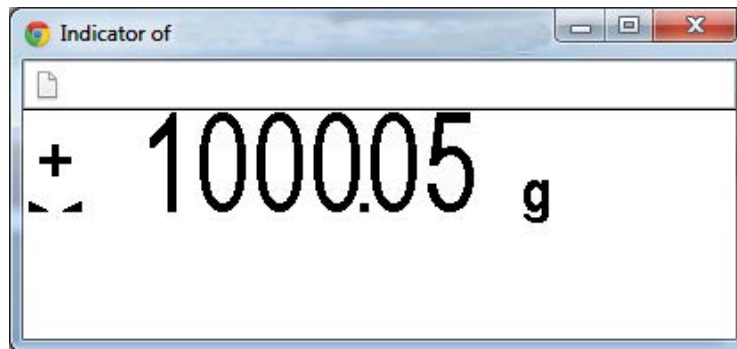



4. Click on the  symbol to return to the WEB menu.

9.2.3 Configuration printout

With the [Configuration Printout] menu item the configuration of the device of the device can be displayed, saved and printed out.

Note:

The configuration printout can be activated via  and  (clicked one after the other); see Chapter [7.15.4](#).

1. Click the [Configuration Printout] menu item in the WEB menu.

- ▷ The configuration of the device is shown on the display.

```

Datei  Bearbeiten  Ansicht  Favoriten  Extras  ?
-----
Neue Registerkarte                               Strg+T
Registerkarte kopieren                          Strg+K
Neues Fenster                                   Strg+N
Neue Sitzung
Öffnen...                                       Strg+O
Mit Microsoft Visual Studio 2005 Tools for Applications bearbeiten
Speichern
Speichern unter...                              Strg+S
Registerkarte schließen                          Strg+W
-----
Seite einrichten...
Drucken...                                       Strg+P
Druckvorschau...
-----
Senden                                          ▶
Importieren und Exportieren...
-----
Eigenschaften
Offlinebetrieb
Beenden

PIN      :      0
Sequence number :      44537
Set Tare Key   :   tare & reset tare
Set zero key   : only when not tared

Printing parameter
=====
Printing mode   :      Cyclic
Printing interval :      10
Printing interval u:      Seconds
PrintlayoutItem1 :      Sequence number
PrintlayoutItem2 :      Gross weight
PrintlayoutItem3 :      CR/LF
PrintlayoutItem4 :      -none-
PrintlayoutItem5 :      -none-
PrintlayoutItem6 :      -none-

```

2. Click on [File]- [Save as...].
3. Create and open the required directory e.g. on the notebook.
4. Click on [Save] to save the text file in the relevant directory.

```

Configuration of PR5230
=====
Printed      :2015-10-21 11:58:52
Firmware    :Rel 03.20.01.260210
              2015-06-30 07:16
Standard    : Rel 01.00.04.478
              2015-03-23 11:07
Bios        :Rel 03.20.01.260210
              2015-06-30 07:16
Boardnumber :          327932910

HW-Options
=====
Builtin      RS232
Builtin      RS485
Builtin      digital i/o
Slot A PR5230/W1 standard ADC

Operating parameter
=====
Application  :          Standard
Address     :          B
PIN         :          0
Sequence number :          44537
Set Tare Key : tare & reset tare
Set zero key : only when not tared

Printing parameter
=====
Printing mode :          Cyclic
Printing interval :          10
Printing interval u:          Seconds
PrintlayoutItem1 :          Sequence number
PrintlayoutItem2 :          Gross weight
PrintlayoutItem3 :          CR/LF
PrintlayoutItem4 :          -none-
PrintlayoutItem5 :          -none-
PrintlayoutItem6 :          -none-

Limits
=====
Limit 1 on   :          1 kg
              Action :          -no action-
Limit 1 off  :          2 kg
              Action :          -no action-
Limit 2 on   :          3 kg
              Action :          -no action-
Limit 2 off  :          4 kg
              Action :          -no action-
Limit 3 on   :          5 kg
              Action :          -no action-
Limit 3 off  :          6 kg
              Action :          -no action-

Digital I/O
=====
Output 1     :marker bit 1 X64=1
Output 2     :marker bit 2 X65=1
Output 3     :marker bit 3 X66=1
Input 1 on   :set zero X112=1
              Condition :no condition -----
Input 1 off  :          -no action-
Input 2 on   :set tare X113=1
              Condition :no condition -----

```

5. Click on [Print]- [File...].
6. Select the connected printer and click [Print].
7. Click on the  symbol in the Internet browser to return to the WEB menu.

9.2.4 Log files

With the [Logfiles] menu item the logfiles of the device can be displayed, saved and printed out.

1. Click the [Logfiles] menu item in the WEB menu.
 - ▷ A list of logfiles is shown on the display.

```

DIR of /var/log/
8778 04.12.1999 18:09:27 logd.1      text/plain
10008 30.11.1999 18:52:15 logd.0      text/plain
5437 30.11.1999 00:00:08 messages    text/plain
    
```

2. Click on the desired file.

```

<46>Nov 30 00:00:03 syslogd started:
<45>Nov 30 00:00:03 klogd: (19991030T000003443) klogd running
<12>Nov 30 00:00:03 klogd: (19991030T000003559) Linux version 2.6.10-uc0 (software@sartorius.com) (gcc version 3.4.0) 260208[M1] 2015-04-10-10:47:24
<14>Nov 30 00:00:03 klogd: (19991030T000003564) ^O^M
<12>Nov 30 00:00:03 klogd: (19991030T000003569) uClinux/COLDFIRE(m5270/5271/5274/5275)
<14>Nov 30 00:00:03 klogd: (19991030T000003579) COLDFIRE port done by Greg Ungerer, gerg@snapgear.com
<14>Nov 30 00:00:03 klogd: (19991030T000003584) Flat model support (C) 1998,1999 Kenneth Albanowski, D. Jeff Dionne
<15>Nov 30 00:00:03 klogd: (19991030T000003589) On node 0 totalpages: 4096
<15>Nov 30 00:00:03 klogd: (19991030T000003594) DMA zone: 0 pages, LIFO batch:1
<15>Nov 30 00:00:03 klogd: (19991030T000003599) Normal zone: 4096 pages, LIFO batch:1
<15>Nov 30 00:00:03 klogd: (19991030T000003604) HighMem zone: 0 pages, LIFO batch:1
<12>Nov 30 00:00:03 klogd: (19991030T000003610) Built 1 zonelists
<12>Nov 30 00:00:03 klogd: (19991030T000003615) Kernel command line: console=ttyS2,19200
<12>Nov 30 00:00:03 klogd: (19991030T000003620) PID hash table entries: 128 (order: 7, 2048 bytes)
<12>Nov 30 00:00:03 klogd: (19991030T000003625) Dentry cache hash table entries: 4096 (order: 2, 16384 bytes)
<12>Nov 30 00:00:03 klogd: (19991030T000003630) Inode-cache hash table entries: 2048 (order: 1, 8192 bytes)
<14>Nov 30 00:00:03 klogd: (19991030T000003636) Memory available: 15136k/16384k RAM, 0k/0k ROM (837k kernel code, 153k data)
<15>Nov 30 00:00:03 klogd: (19991030T000003641) Calibrating delay loop... 65.74 BogoMIPS (lpj=164352)
<12>Nov 30 00:00:03 klogd: (19991030T000003646) Mount-cache hash table entries: 512 (order: 0, 4096 bytes)
<14>Nov 30 00:00:03 klogd: (19991030T000003651) NET: Registered protocol family 16
<12>Nov 30 00:00:03 klogd: (19991030T000003656) Sartorius EventFlags installed
<12>Nov 30 00:00:03 klogd: (19991030T000003661) Sartorius QSPI device driver installed
<12>Nov 30 00:00:03 klogd: (19991030T000003666) Sartorius HMS Anybus-CC device driver installed
<12>Nov 30 00:00:03 klogd: (19991030T000003671) Sartorius Combi Keyboard registered
<12>Nov 30 00:00:03 klogd: (19991030T000003676) Sartorius XBP1 driver installed
<12>Nov 30 00:00:03 klogd: (19991030T000003681) ColdFire internal UART serial driver version 1.00
<12>Nov 30 00:00:03 klogd: (19991030T000003686) fec: PHY @ 0x1, ID 0x00221619 -- KS5721BL
<12>Nov 30 00:00:03 klogd: (19991030T000003691) ttyS1 at 0x40000240 (irq = 78) is a builtin ColdFire UART
<12>Nov 30 00:00:03 klogd: (19991030T000003696) ttyS2 at 0x40000280 (irq = 79) is a builtin ColdFire UART
<14>Nov 30 00:00:03 klogd: (19991030T000003697) io scheduler noop registered
<14>Nov 30 00:00:03 klogd: (19991030T000003702) io scheduler deadline registered
<12>Nov 30 00:00:03 klogd: (19991030T000003707) eth0: FEC ENET Version 0.2, 00:90:6c:13:1f:48
<14>Nov 30 00:00:03 klogd: (19991030T000003712) fec: PHY @ 0x1, ID 0x00221619 -- KS5721BL
<14>Nov 30 00:00:03 klogd: (19991030T000003717) elevator: using deadline as default io scheduler
<14>Nov 30 00:00:03 klogd: (19991030T000003722) mtd0 00000000 00020000 "PR5220-Bios 04.00.02-IBC-RC2.260210[M3-u1] 2015-07-10-10:15:15"
<14>Nov 30 00:00:03 klogd: (19991030T000003992) mtd1 00020000 0038AC10 "PR5220-Firm 04.00.02-IBC-RC2.260210[M5] 2015-06-29-11:14:43"
<14>Nov 30 00:00:03 klogd: (19991030T000003998) mtd2 003B0000 00001410 "PR5220-App1-PR5220-Application 01.00.06 2010-10-15-11:14:43"
<14>Nov 30 00:00:04 klogd: (19991030T000004003) mtd3 003C0000 0000C810 "PR5220-App1-IBC 01.00.00.2 2015-04-29-11:14:43"
<14>Nov 30 00:00:04 klogd: (19991030T000004008) bootdev=1
<13>Nov 30 00:00:04 klogd: (19991030T000004013) flash device: 800000 at f0000000
<13>Nov 30 00:00:04 klogd: (19991030T000004018) Creating 4 MTD partitions on "FLASH":
    
```

Zurück	Alt+Linkspfeil
Vorwärts	Alt+Rechtspfeil
Neu laden	Strg+R
Speichern unter...	Strg+S
Drucken...	Strg+P
Übersetzen in Deutsch	
Seitenquelltext anzeigen	Strg+U
Seiteninfo anzeigen	
Element untersuchen	Strg+Umschalt+I

3. Click on [Save as].
4. Create and open the required directory e.g. on the notebook.
5. Click on [Save] to save the text file in the relevant directory.
6. Press the right mouse button.

```

<46>Nov 30 00:00:03 syslogd started:
<45>Nov 30 00:00:03 klogd: (19991030T000003443) klogd running
<12>Nov 30 00:00:03 klogd: (19991030T000003559) Linux version 2.6.10-uc0 (software@sartorius.com) (gcc version 3.4.0) 260208[M1] 2015-04-10-10:47:24
<14>Nov 30 00:00:03 klogd: (19991030T000003564) ^O^M
<12>Nov 30 00:00:03 klogd: (19991030T000003569) uClinux/COLDFIRE(m5270/5271/5274/5275)
<14>Nov 30 00:00:03 klogd: (19991030T000003579) COLDFIRE port done by Greg Ungerer, gerg@snapgear.com
<14>Nov 30 00:00:03 klogd: (19991030T000003584) Flat model support (C) 1998,1999 Kenneth Albanowski, D. Jeff Dionne
<15>Nov 30 00:00:03 klogd: (19991030T000003589) On node 0 totalpages: 4096
<15>Nov 30 00:00:03 klogd: (19991030T000003594) DMA zone: 0 pages, LIFO batch:1
<15>Nov 30 00:00:03 klogd: (19991030T000003599) Normal zone: 4096 pages, LIFO batch:1
<15>Nov 30 00:00:03 klogd: (19991030T000003604) HighMem zone: 0 pages, LIFO batch:1
<12>Nov 30 00:00:03 klogd: (19991030T000003610) Built 1 zonelists
<12>Nov 30 00:00:03 klogd: (19991030T000003615) Kernel command line: console=ttyS2,19200
<12>Nov 30 00:00:03 klogd: (19991030T000003620) PID hash table entries: 128 (order: 7, 2048 bytes)
<12>Nov 30 00:00:03 klogd: (19991030T000003625) Dentry cache hash table entries: 4096 (order: 2, 16384 bytes)
<12>Nov 30 00:00:03 klogd: (19991030T000003630) Inode-cache hash table entries: 2048 (order: 1, 8192 bytes)
<14>Nov 30 00:00:03 klogd: (19991030T000003636) Memory available: 15136k/16384k RAM, 0k/0k ROM (837k kernel code, 153k data)
<15>Nov 30 00:00:03 klogd: (19991030T000003641) Calibrating delay loop... 65.74 BogoMIPS (lpj=164352)
<12>Nov 30 00:00:03 klogd: (19991030T000003646) Mount-cache hash table entries: 512 (order: 0, 4096 bytes)
<14>Nov 30 00:00:03 klogd: (19991030T000003651) NET: Registered protocol family 16
<12>Nov 30 00:00:03 klogd: (19991030T000003656) Sartorius EventFlags installed
<12>Nov 30 00:00:03 klogd: (19991030T000003661) Sartorius QSPI device driver installed
<12>Nov 30 00:00:03 klogd: (19991030T000003666) Sartorius HMS Anybus-CC device driver installed
<12>Nov 30 00:00:03 klogd: (19991030T000003671) Sartorius Combi Keyboard registered
<12>Nov 30 00:00:03 klogd: (19991030T000003676) Sartorius XBP1 driver installed
<12>Nov 30 00:00:03 klogd: (19991030T000003681) ColdFire internal UART serial driver version 1.00
<12>Nov 30 00:00:03 klogd: (19991030T000003686) fec: PHY @ 0x1, ID 0x00221619 -- KS5721BL
<12>Nov 30 00:00:03 klogd: (19991030T000003691) ttyS1 at 0x40000240 (irq = 78) is a builtin ColdFire UART
<12>Nov 30 00:00:03 klogd: (19991030T000003696) ttyS2 at 0x40000280 (irq = 79) is a builtin ColdFire UART
<14>Nov 30 00:00:03 klogd: (19991030T000003697) io scheduler noop registered
<14>Nov 30 00:00:03 klogd: (19991030T000003702) io scheduler deadline registered
<12>Nov 30 00:00:03 klogd: (19991030T000003707) eth0: FEC ENET Version 0.2, 00:90:6c:13:1f:48
<14>Nov 30 00:00:03 klogd: (19991030T000003712) fec: PHY @ 0x1, ID 0x00221619 -- KS5721BL
<14>Nov 30 00:00:03 klogd: (19991030T000003717) elevator: using deadline as default io scheduler
<14>Nov 30 00:00:03 klogd: (19991030T000003722) mtd0 00000000 00020000 "PR5220-Bios 04.00.02-IBC-RC2.260210[M3-u1] 2015-07-10-10:15:15"
<14>Nov 30 00:00:03 klogd: (19991030T000003992) mtd1 00020000 0038AC10 "PR5220-Firm 04.00.02-IBC-RC2.260210[M5] 2015-06-29-11:14:43"
<14>Nov 30 00:00:03 klogd: (19991030T000003998) mtd2 003B0000 00001410 "PR5220-App1-PR5220-Application 01.00.06 2010-10-15-11:14:43"
<14>Nov 30 00:00:04 klogd: (19991030T000004003) mtd3 003C0000 0000C810 "PR5220-App1-IBC 01.00.00.2 2015-04-29-11:14:43"
<14>Nov 30 00:00:04 klogd: (19991030T000004008) bootdev=1
<13>Nov 30 00:00:04 klogd: (19991030T000004013) flash device: 800000 at f0000000
<13>Nov 30 00:00:04 klogd: (19991030T000004018) Creating 4 MTD partitions on "FLASH":
<13>Nov 30 00:00:04 klogd: (19991030T000004024) 0x00000000-0x00200000 : "PR5220-Bios 04.00.02-IBC-RC2.260210[M3-u1] 2015-07-10-10:15:15"
<13>Nov 30 00:00:04 klogd: (19991030T000004034) 0x003B0000-0x003B1410 : "PR5220-Firm 04.00.02-IBC-RC2.260210[M5] 2015-06-29-11:14:43"
<13>Nov 30 00:00:04 klogd: (19991030T000004040) 0x003C0000-0x003C810 : "PR5220-App1-PR5220-Application 01.00.06 2010-10-15-11:14:43"
<13>Nov 30 00:00:04 klogd: (19991030T000004045) flash device initialized
    
```

Zurück	Alt+Linkspfeil
Vorwärts	Alt+Rechtspfeil
Neu laden	Strg+R
Speichern unter...	Strg+S
Drucken...	Strg+P
Übersetzen in Deutsch	
Seitenquelltext anzeigen	Strg+U
Seiteninfo anzeigen	
Element untersuchen	Strg+Umschalt+I

7. Click on [Print...].

8. Select the connected printer and click [Print].
9. Click on the  symbol in the Internet browser to return to the WEB menu.

9.2.5 Screenshots

With the [Screenshot] menu item a screenshot of the device can be displayed, saved and printed out.

1. Click on the [Screenshot] menu item in the WEB menu.
 - ▷ The current device display is shown as a screenshot.
2. Press the right mouse button.

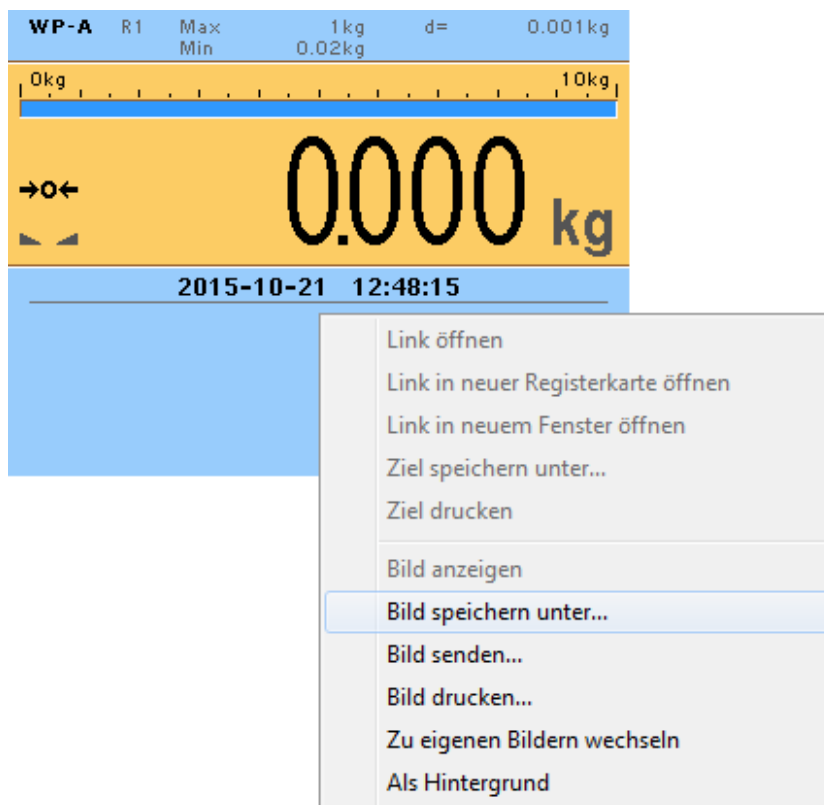

3. Click on [Save image as...].
4. Create and open the required directory e.g. on the notebook.
5. Click on [Save] to save the graphic file in the relevant directory.
6. Press the right mouse button.

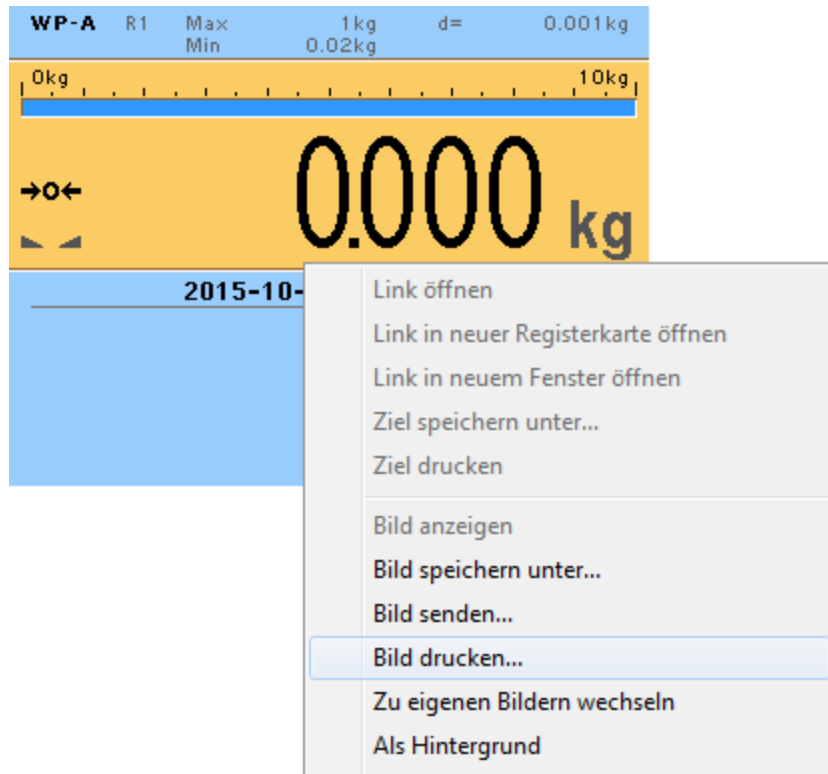

7. Click on [Print...].
8. Select the connected printer and click [Print].
9. Click on the  symbol in the Internet browser to return to the WEB menu.

9.2.6 Error log

With the [Show error Log] menu item the error log of the device can be displayed, saved and printed out.

1. Click the [Show error Log] menu item in the WEB menu.
The error log of the device is shown on the display.
2. Press the right mouse button.

Record	Type	Message
1	RESET	RCM: Watchdog Reset

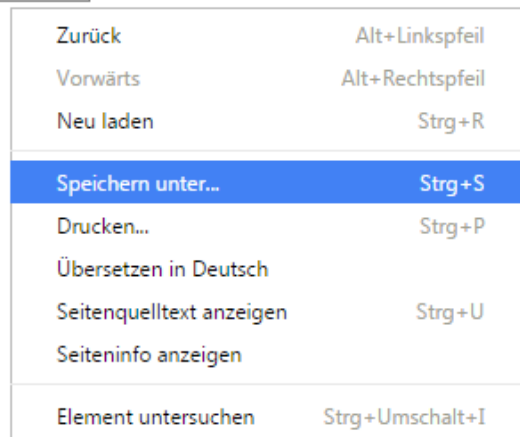

3. Click on [Save as].

4. Create and open the required directory e.g. on the notebook.
5. Click on [Save] to save the text file in the relevant directory.
6. Press the right mouse button.

Record	Type	Message
1	RESET	RCM: Watchdog Reset

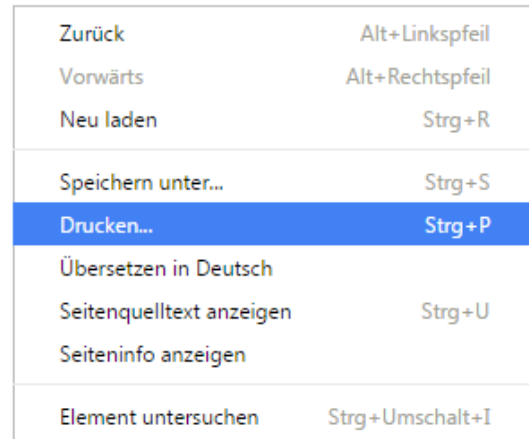

7. Click on [Print...].
8. Select the connected printer and click [Print].
9. Click on the  symbol in the Internet browser to return to the WEB menu.

9.2.7 Event memory

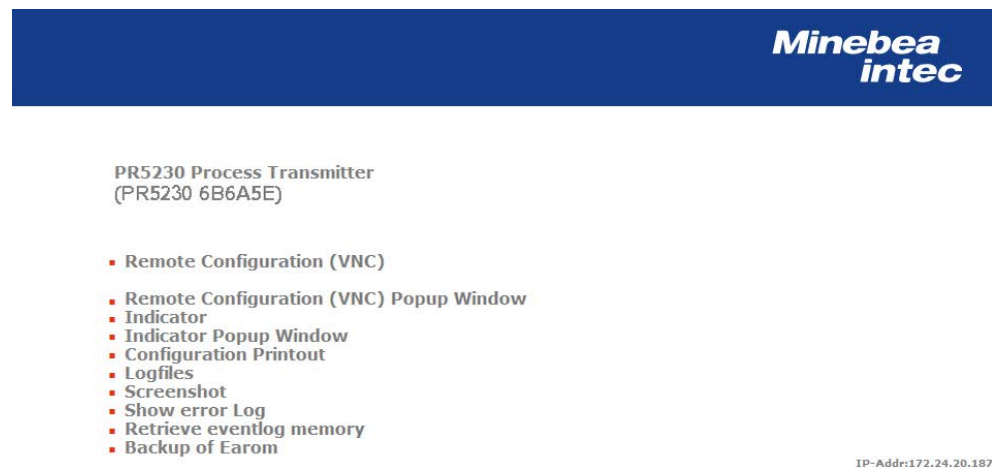

With the [Retrieve eventlog memory] menu item the logged events can be displayed and saved.

This event log memory contains events, which are stored as altered data in EEPROM with a time stamp.

The 4 event types are:

- fatal error
- Setup
- Indicator
- Powerfail

The individual types are distinguished by corresponding error/status codes.

Example:

Type	Date	Time	Code	Cond
Indicator	2013-06-24	11:01:18 AM	265	on
fatal error	2013-06-23	4:52:29 PM	2050	on
Powerfail	2013-06-24	10:15:57 AM	0	on
Setup	2013-06-24	10:59:57 AM	1025	on

9.2.7.1 fatal error

Code	Event
2049	Watchdog
2050	Fatal Error
2051	Reset completed.
2052	Assert error
2053	Exception error
2054	Hardware error

9.2.7.2 Setup

Code	Event
512	New Calibration was started.
513	Dead load was reset with mV/V.
514	Span was reset with mV/V.
515	New dead load was reset with weight.
516	New span was reset with weight.
517	New scale end value was reset.
518	New verification interval was set.
519	Calibration was saved.
520	Changes were undone.
768	Wrong PIN was entered.
769	EAROM was cleared.
771	Device was turned on.
1024	Serial parameters were saved.
1025	Assignment of serial interfaces was changed.
1027	Network parameter were changed.
1028	Printer parameter were changed.

Code	Event
1029	Software parameters were changed.
1030	Fieldbus parameters were changed.
1031	Digital inputs and outputs were changed.
1032	Limit parameters were changed.
1033	Analog output parameters were changed.
1080	ADC parameters changed after download via HTTP.
1081	Core EEPROM were changed after download via HTTP.
2305	No ADC was detected.

9.2.7.3 Indicator

Code	Event
257	Internal arithmetic error
258	Overload
259	No valid ADC values available.
262	No Sense-Input voltage available.
263	Negative input voltage (wrong polarity) available.
265	Faulty communication with ADC

9.2.7.4 Powerfail

Only the instrument switch-on is recorded.

9.2.7.5 Open/save eventlog memory

1. Click on the [Retrieve eventlog memory] menu item in the WEB menu.
A selection window opens.
2. Click on [Open] to open the CSV file.
The CSV file are loaded and opened.
3. Click on [Save]/[Save as] to save the CSV file.
4. Create and open the required directory e.g. on the notebook.
5. Click on [Save] to save the CSV file in the relevant directory.

9.2.8 Configuration data

The configuration and calibration data of the EAROMs can be saved for back-up on the Notebook and downloaded, if necessary.

- Click the [Backup of Earom] menu item in the WEB menu.
 - ▷ The backup/restore menu is shown on the display.

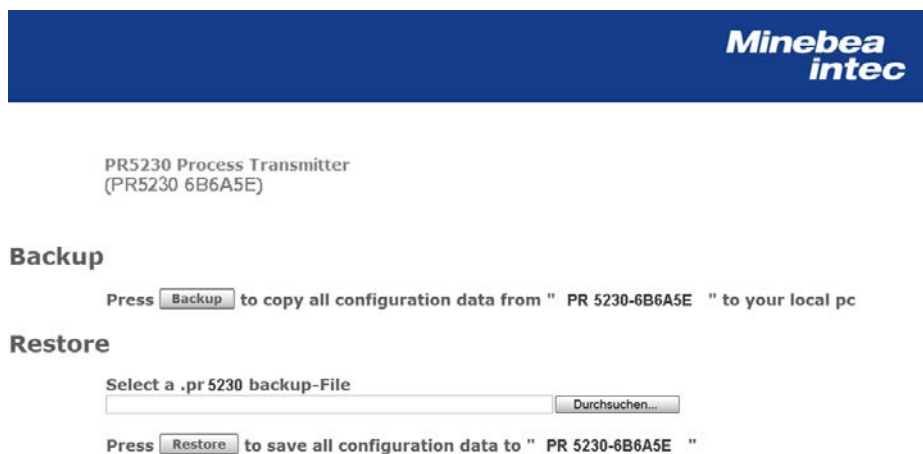

9.2.8.1 Saving configuration and calibration data

1. Click on [Backup] to create a backup .g. on the notebook.
2. Click on [Save as].
3. Create and open the required directory e.g. on the notebook.
4. Click on [Save] to save the backup file in the relevant directory.

9.2.8.2 Loading configuration and calibration data into the device

NOTICE

All data which can be configured in the Setup menu are overwritten!



- ▶ If the file is loaded into several devices, changing the network settings and the host name is indispensable!

1. Open the CAL switch; see Chapter [7.1.3.1](#).
2. Click on [Select File] (depending on the Internet browser).
3. e.g. on the notebook, navigate to the folder where the backup file was saved.
4. Select Backup file.
5. Click on [Restore].
 - ▷ The selected file is loaded into the device.
6. Click on the  symbol in the Internet browser to return to the WEB menu.
7. Close the CAL switch.

9.3 Resetting the device to the factory settings

Note:

Reset to the factory settings is possible only, when the CAL switch is open. The IP address and the Hostname remain unaffected.

1. Click on .
2. Click on .

- ▷ The following prompt window appears:

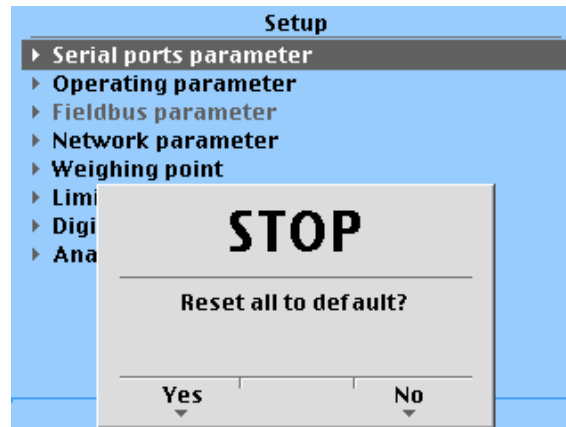

3. Press the [Yes] softkey to reset to the factory settings.
Press [No] if you want to keep the entered values unchanged.

- ▷ The following messages show the respective progress:

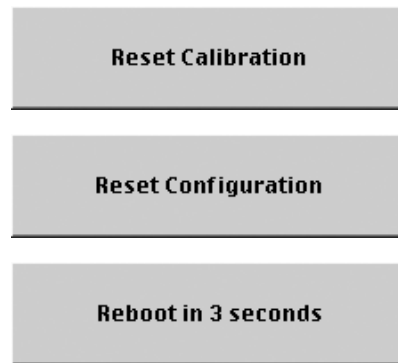

9.4 Updating new software with FlashIt

Note:

Always flash/load the BIOS into the device first, and then the firmware&application.

9.4.1 Updating in network with a DHCP service

Requirements:

- Device and Notebook/PC are connected to the network.
- The automatic address assignment "DHCP" is activated in the device and in the notebook/PC, see Chapter [7.15.6](#).
- The "FlashIt!32" program (in a directory on the enclosed CD-ROM) is installed on the notebook/PC.
- The "FlashIt!32" program is started.

9.4.1.1 Operations at the device

⚠ WARNING

Working on the device while it is switched on may have life-threatening consequences.

- ▶ Product operation must be performed by trained and qualified personnel who are aware of and able to deal with the related hazards and take suitable measures for self-protection.

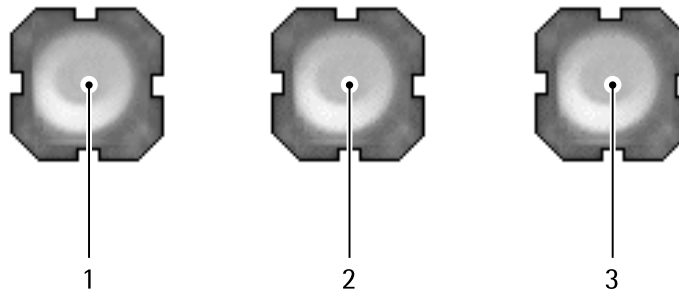

1. Open the door of the instrument.
2. Press keys (1) and (3) simultaneously and follow by pressing key (2) three times.
 - ▷ The following is displayed:

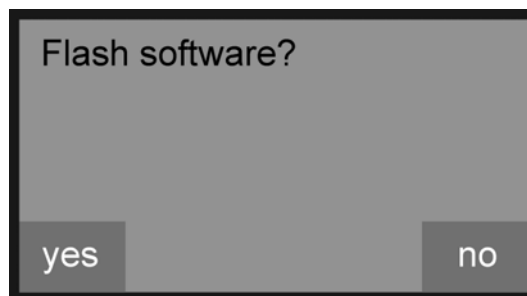

3. Press the (1) key to confirm the loading of the software.
 - ▷ The following is displayed:

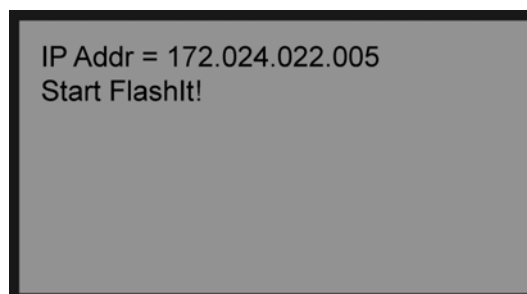

Now the device is ready to load the software.

9.4.1.2 Loading the software on your notebook/PC

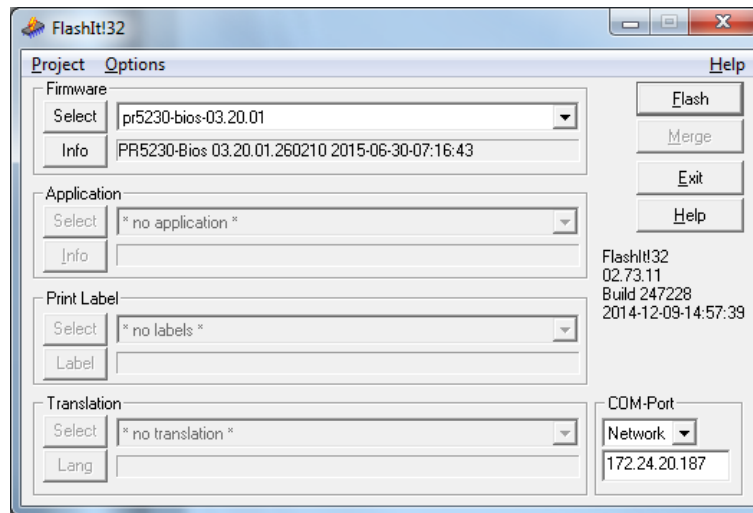

1. Click the relevant file in the "Explorer" with the mouse and drag it into the [Select] window, (or use 'Copy and paste').
2. Under [COM-Port] select "Network" and enter the devices IP addresses.
3. Click [Flash] to start the procedure.
 - ▶ As soon as software loading is completed the device will be re-started.
4. Load next file, as described.

9.4.2 Updating via a point-to-point connection with DHCP service

Requirements:

- Device and notebook/PC are connected to each other.
- The automatic address assignment "DHCP" is activated in the device and in the notebook/PC; see Chapter [7.15.6](#).
- The "FlashIt!32" program (in a directory on the enclosed CD-ROM) is installed on the notebook/PC.
- The "FlashIt!32" program is started.

9.4.2.1 Operations at the device

WARNING

Working on the device while it is switched on may have life-threatening consequences.

- ▶ Product operation must be performed by trained and qualified personnel who are aware of and able to deal with the related hazards and take suitable measures for self-protection.

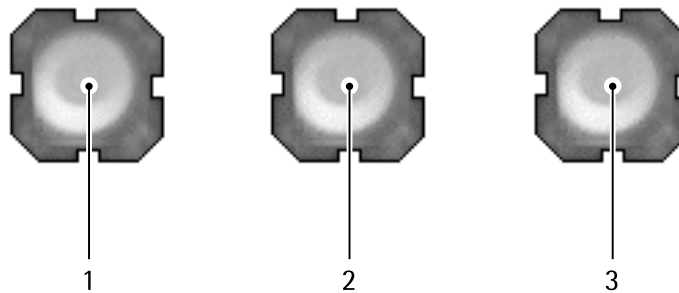

1. Open the door of the instrument.
2. Press keys (1) and (3) simultaneously and follow by pressing key (2) three times.
 - ▷ The following is displayed:

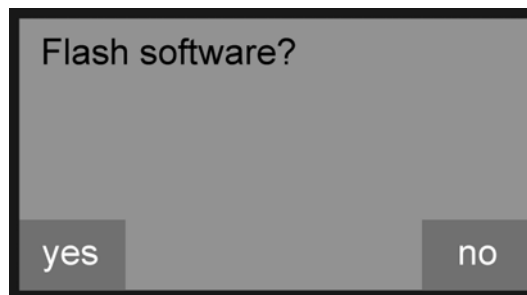

3. Press the (1) key to confirm the loading of the software.
 - ▷ The following is displayed:

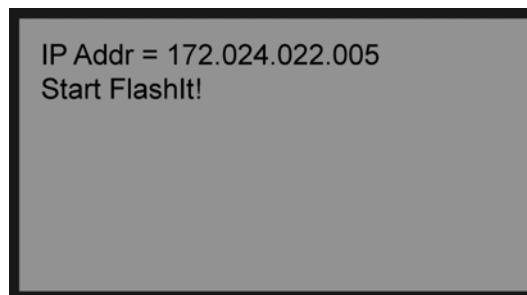

Now the device is ready to load the software.

9.4.2.2 Loading the software on your notebook/PC

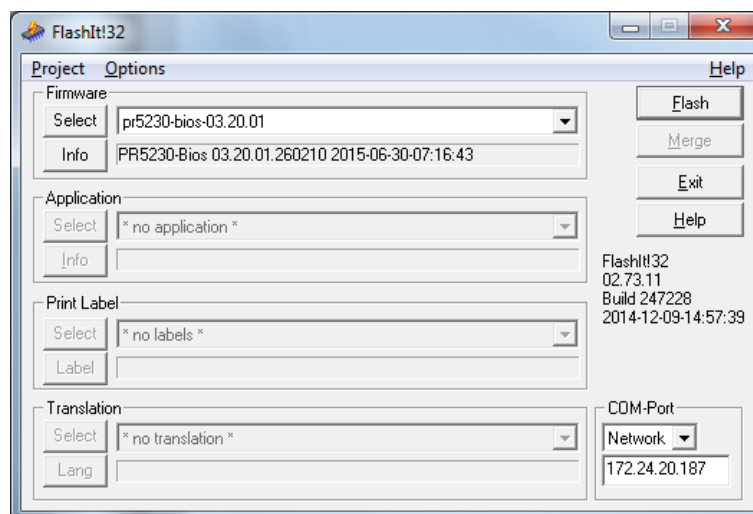

1. Click the relevant file in the "Explorer" with the mouse and drag it into the [Select] window, (or use 'Copy and paste').
2. Under [COM-Port] select "Network" and enter the devices IP addresses.
3. Click [Flash] to start the procedure.
 - ▷ As soon as software loading is completed the device will be re-started.
4. Load next file, as described.

9.4.3 Updating with a fixed IP address

Requirements:

- Device and notebook/PC are connected to a network/each other.
- The automatic address assignment "DHCP" is deactivated in the device and in the notebook/PC, see Chapter [7.15.6](#).
- Notebook/PC is set to a fixed IP address.

Note:

On a point-to-point connection the device and notebook/PC must be set to a fixed IP address which has the same address range given by the subnet mask.

Example:

PR 5230: IP address 192.24.22.1

Notebook/PC: IP address 192.24.22.2

Device and notebook/PC have the subnet mask 255.255.255.0.

- The "FlashIt!32" program (in a directory on the enclosed CD-ROM) is installed on the notebook/PC.
- The "FlashIt!32" program is started.

9.4.3.1 Device presettings in the Setup menu

1. Click on  - [Network parameter].

Setup/Network parameter	
HW address	00:90:6C:6A:6B:5E
Hostname	PR 5230-6A6B5E
Use DHCP	<input type="checkbox"/>
IP address	0.0.0.0
Subnet mask	255.255.255.0
Default gateway	0.0.0.0
Remote access	
VNC-Client	255.255.255.255

2. Deactivate [Use DHCP].
3. Enter the corresponding IP address.

Note:

On a point-to-point connection the device and notebook/PC must be set to a fixed IP address which has the same address range given by the subnet mask.

Example:

PR 5230: IP address 192.24.22.1

Notebook/PC: IP address 192.24.22.2

Device and notebook/PC have the subnet mask 255.255.255.0.

4. Enter the corresponding subnet mask.
5. Press  to exit the window and to save the changes.

9.4.3.2 Operations at the device**⚠ WARNING**

Working on the device while it is switched on may have life-threatening consequences.

- ▶ Product operation must be performed by trained and qualified personnel who are aware of and able to deal with the related hazards and take suitable measures for self-protection.

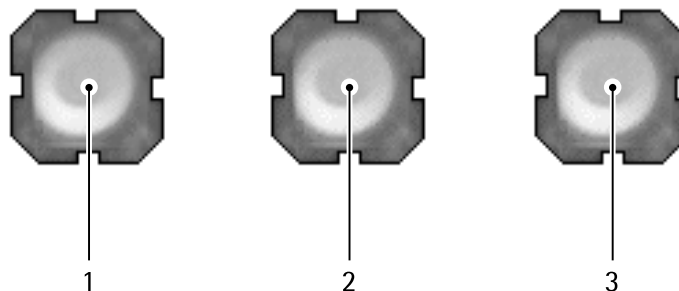

1. Open the door of the instrument.
2. Press keys (1) and (3) simultaneously and follow by pressing key (2) three times.
 - ▷ The following is displayed:

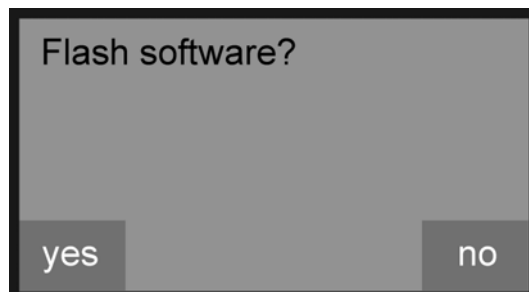

3. Press the (1) key to confirm the loading of the software.

- ▷ The following is displayed:

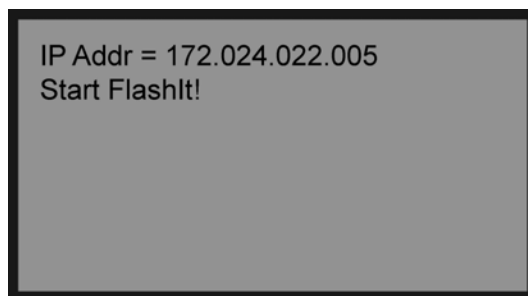

Now the device is ready to load the software.

9.4.3.3 Loading the software on your notebook/PC

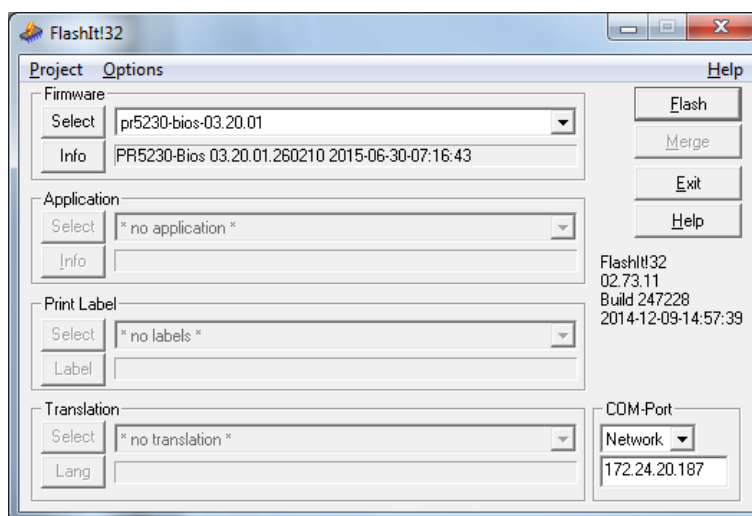

1. Click the relevant file in the "Explorer" with the mouse and drag it into the [Select] window, (or use 'Copy and paste').
2. Under [COM-Port] select "Network" and enter the devices IP addresses.
3. Click [Flash] to start the procedure.
 - ▷ As soon as software loading is completed the device will be re-started.
4. Load next file, as described.

10 ModBus protocol

10.1 General description

The ModBus protocol implemented in the device enables rapid, simple, and reliable communication between a PC or SPS and up to a maximum of 127 devices.

The ModBus protocol allows access to all data published in the SPM table of the relevant application.

Implementation:

The functions 1, 2, 3, 4, 5, 6, 8, 15, and 16 are supported.

Bits can only be read or set individually or in groups of eight.

10.2 SPM data in PR 1612 ModBus mode

For access via ModBus, the PR 1612 ModBus mode is switched on via  - [Serial ports]- [ModBus-RTU]- [Param]- [ModBus mode]- [PR 1612 ModBus].

Read data

Byte address	Weight in 32-bit integer format
60...63	Gross weight
64...67	Net weight (gross if not tared)
68...71	Tare weight (0 if not tared)

Read data

Address	Read "Word" (display in binary format)
W201	0E00000T 00000000 E: ADC error T: Instrument is tared.
W203	000S00MZ 00000000 S: Device is in setup mode. M: Weight is stable (standstill). Z: Weight within ¼ d of 0
W204	0000D000 00000000 D: Gross weight <0 or >Max (dimmed)
W205	TA000000 00000000 T: Instrument is tared. A: Analog test is active.
W231	00021MRZ 00000000 2: Limit 2 1: Limit 1 M: Weight is stable (standstill). R: Weight within zero-setting range Z: Weight within ¼ d of 0

Write data

Bit address	Value in 32-bit integer format
W100	Zero device: Write value 256
W101	Tare device: Write value 256 Reset the tare of the device: Write value 512

11 SMA protocol

11.1 General information

The protocol of the "Scale Manufacturers Association" (SMA) provides a simple access to the scale. It can be used for reading data, or for executing functions.

The RS-232 or RS-485 interface is used as an interface.

Fixed interface settings are 8 bits, no parity and 1 stop bit.

The commands to the transmitter are printable ASCII characters starting with <LF> = 0A hex and ending with <CR> = 0D hex.

The transmitter sends a reply on each received command after approx. 100 μ s. With commands that wait for standstill of the weight value, the reply can be delayed by the timeout.

The following commands are supported:

W, Z, D, A, B, <ESC>, H, P, Q, R, S, T, M, C, I, N

12 Fieldbus interface

12.1 General notes

The PR 5230 can be turned into a field bus slave by inserting a field bus interface card . This enables one or more devices to be included under a communication master (e.g., Siemens S7 ProfiBus).

The update rate is 50 ms.

The interface is configured under -[Fieldbus parameter] in the device. The corresponding field bus protocol (in this case: Ethernet-IP) is shown.

Setup/Fieldbus parameter	
Fieldbus protocol	EtherNet/IP
IP address	172.24.24.88
Subnet mask	255.255.240.0

The field bus exchanges its data cyclically with each slave. That means: In each cycle, the entire data range is written and read, even if there are no changes to the data content.

Concept definition

Term/Abbreviation	Description
Master	Field bus master, usually an SPS
Slave	Field bus device
MOSI	Master Out Slave In = data is written from the SPS via the field bus to the device.
MISO	Master In Slave Out = data is returned from the device via the field bus to the SPS.

12.2 Scale protocol (8-byte) for the "Standard" application

The interface works with an 8-byte write window and an 8-byte read window for each weighing point.

Note:

All fieldbus data is only valid, if 'Read_Value_Selected' has been reflected.

12.2.1 Data exchange range

Overview

Byte	0, 1, 2, 3	4	5	6, 7
MOSI	Write data	Read_Value_Select	Write_Value_Select	Control bits (control bits)
MISO	Read data	Read_Value_Selected	Status bits (status bits)	Status bits (status bits)

Write window (MOSI)

Byte	Field	Description
0	Write data (MSB)	Contains the data to be written, e.g., analog output.
1	Write data	
2	Write data	
3	Write data (LSB)	
4	Read_Value_Select	Selects the function for reading data.
5	Write_Value_Select	Selects the function for writing data.
6	free free free free free free free free free	In direct access, control bits are independent of the write or read request. "Free" bits are application specific.
7	free free Res Power Res Test Set Test Res Tare Set Tare Set Zero	
	Bit 7 Bit 6 Bit 5 Bit 4 Bit 3 Bit 2 Bit 1 Bit 0	

Field	Size	Function
Write data	4 bytes	Data to be written as a binary 32-bit value with plus or minus sign. Data type: DINT
Read_Value_Select	1 byte	Function for selecting the read request
Write_Value_Select	1 byte	Function for selecting the write request
ResPower	1 bit	PowerFail is reset.
ResTest	1 bit	The test operating mode is finished.
SetTest	1 bit	The test operating mode is started. Now the test value can be read out by reading the gross weight.
ResTare	1 bit	Tare is reset.
SetTare	1 bit	The weighing point is tared.
SetZero	1 bit	The weighing point is set to zero.

Read window (MISO)

Byte	Field	Description						
0	Read data (MSB)	Contains the data to be read, e.g. gross value.						
1	Read data							
2	Read data							
3	Read data (LSB)							
4	Read_Value_Selected	Read_Value_Select (function) from the write window is mirrored if the data in "Read data" is available.						
5	Write Active	In direct access, status bits are independent of the write or read request. "Free" bits are application specific.						
	Power Fail							
	free free free free free							
6	Cmd Busy	Tare Active Cal Changed Test Active						
	Cmd Error free free free							
7	OutOf Range	Above Max ADU Error						
	Standstill Inside ZSR Center Zero Below Zero Overload							
	Bit 7	Bit 6	Bit 5	Bit 4	Bit 3	Bit 2	Bit 1	Bit 0

Field	Size	Function
Read data	4 bytes	Data to be read as a binary 32-bit value with plus or minus sign. Data type: DINT
Read_Value_Selected	1 byte	Acknowledgment of the transmitted function number.
WriteActive	1 bit	The function selected with Write_Value_Select has been executed once. This bit is deleted if Write_Value_Select is set to 0.
PowerFail	1 bit	Is set when switching on the device. Is reset by ResPower with transition from 0→1.
CmdBusy	1 bit	The device is busy executing a function (e.g., waiting for a standstill for taring)
CmdError	1 bit	The device has interrupted the execution of a command (e.g., standstill could not be reached within the defined standstill time). The error number can be read from "LASTERROR", see Chapter 12.2.5.5 .
Tare_Active	1 bit	The scale has been tared.
Cal_Changed	1 bit	The device has been calibrated. When this bit is 1, the weighing point parameters (EX-PO/UNIT/STEP+FSD) must be read again. Set after "Power on" and reset after reading the FSD.

Field	Size	Function
Test_Active	1 bit	The device executes the ADC test. The read weight value is not the gross value, but the test value.
OutOfRange	1 bit	Below zero or above max. (FSD).
Standstill	1 bit	The scale is stable.
InsideZSR	1 bit	The gross weight value is within the zero setting range.
CenterZero	1 bit	The weight value is within center zero (0 ± 0.25 d).
BelowZero	1 bit	The weight value is negative (gross < 0 d).
Overload	1 bit	The weight value has exceeded the measuring range. No valid weight data is specified (gross > FSD+overload).
AboveMax	1 bit	The weight value has exceeded the max. (FSD), but is still within max. + permissible overload (gross \leq FSD+overload).
ADUError	1 bit	AD conversion error, see Chapter 12.2.5.2 .

12.2.2 Reading and writing data with function numbers

12.2.2.1 Reading data

Procedure:

1. Write the function number as **Read_Value_Select** in byte 4 of the write window (e.g., 9 = net weight).
2. Wait until **Read_Value_Selected** in byte 4 of the read window is equal to **Read_Value_Select** of the write window.
 - ▷ The requested value is available in bytes 0-3.

Action of the master	Slave reaction
Write function number to Read_Value_Select .	
	Write requested data in Read_Data (bytes 0-3).
	Copy Read_Value_Select to Read_Value_Selected .
Wait until Read_Value_Selected = Read_Value_Select .	
Read requested data in Read_Data (bytes 0-3).	

12.2.2.2 Writing data

Procedure:

1. Wait until **Write_Active** = 0 in the read window (slave is ready to receive new data).
2. Write value in bytes 0-3 of the write window.

3. Write the function number as **Write_Value_Select** in byte 5 of the write window (e.g., "Basic" application: 190 = analog output 1).
4. Wait until **Write_Active** = 1 in the read window.
5. Write 0 in byte 5 (**Write_Value_Select**).
 - ▷ **Write_Active** is reset.

Action of the master	Slave reaction
Write value in Write_Data (bytes 0-3).	
Write function number to Write_Value_Select .	
	Read data from Write_Data (bytes 0-3).
	Set the Write_Active bit.
Wait until Write_Active has been set.	
Write 0 in Write_Value_Select .	
	Reset the Write_Active bit.

12.2.2.3 Writing bits

In addition to the control bits in bytes 6/7, further bits can be set and, if necessary, reset directly with **Write_Value_Select**.

To set bits 80 to 127, the corresponding function number is written to **Write_Value_Select** (see Chapter [12.2.5](#)).

To reset bits 80 to 89, the corresponding function number +128 (208 to 217) is written to **Write_Value_Select**.

Action of the master	Slave reaction
Writing the bit address as a function number to Write_Value_Select .	
	The bit from Write_Value_Select is set and the corresponding function carried out.
	Set the Write_Active bit.
Wait until Write_Active has been set.	
Write 0 in Write_Value_Select .	
	Reset the Write_Active bit.

12.2.2.4 Reading bits

Reading individual bits which are not contained directly in the read window is only possible with a corresponding function number and the data in **Read_Data** (Byte 0-3) of the read window. In those bytes, the bits must be evaluated individually.

The procedure is the same as that described in Chapter [12.2.2.1](#).

12.2.3 Reading and writing bits directly

For reading status bits and for writing direct control bits, no procedure is required. The general status bits are always provided and need not be requested. The direct control bits are also available continuously.

12.2.3.1 Reading status bit

The status bits in bytes 5-7 of the read window are always available and can be read directly by the master.

12.2.3.2 Writing control bits

Some device functions can be executed by setting bits directly in bytes 6 and 7 (control bytes) of the write window.

Action of the master	Slave reaction
Set bits in the control byte .	Function is executed.
Reset bits in the control byte .	

12.2.4 Waiting for the result of the action

When an action requiring more time is started, the end of execution can also be waited for.

Action of the master	Slave reaction
For setting bits, see Chapter 12.2.2.3 or 12.2.3.2 .	Set the CmdBusy bit.
	Function is executed.
	In the event of an error: Set the CmdError bit and the LastError byte.
	If the function is executed or timeout: reset the CmdBusy bit.
Wait until CmdBusy = 0.	
Check the CmdError bit.	
If CmdError is set: Evaluate the LastError (for function number 4, see Chapter 12.2.5.5)	
Set the ResetError bit (for function number 121, see Chapter 12.2.5.13).	
	The ResetError bit is reset.
	The CmdError bit is reset.

12.2.5 Function numbers

Function numbers are written to MOSI by the master (SPS) and reflected in MISO by the PR 5230.

- Funktionsnummer 0: I/O status bits (read), see Chapter [12.2.5.1](#)
- Function number 1: scale status (read), see Chapter [12.2.5.2](#)
- Function number 4: calibration information, error byte (read), see Chapter [12.2.5.5](#)
- Function number 5: device type and software version (read), see Chapter [12.2.5.6](#)
- Function number 6: serial number of the weighing point (read), see Chapter [12.2.5.7](#)
- Function numbers 8 to 15: weight data (read), see Chapter [12.2.5.9](#)
- Function numbers 24 to 29: Limit value (read/write), see Chapter [12.2.5.10](#)
- Function numbers 30, 31: values of the current weighing point (read), see Chapter [12.2.5.11](#)
- Function numbers 80 to 89: state-controlled action bits (write), see Chapter [12.2.5.12](#)
- Function numbers 112 to 119; 121: transition-controlled action bits (write), see Chapter [12.2.5.13](#)

12.2.5.1 Function number 0: I/O status bits (read)

Dynamic status

	Bit 7	Bit 6	Bit 5	Bit 4	Bit 3	Bit 2	Bit 1	Bit 0
Byte 0						Input 3	Input 2	Input 1
Byte 1						Output 3	Output 2	Output 1
Byte 2						Limit 3	Limit 2	Limit 1
Byte 3								

12.2.5.2 Function number 1: scale status (read)

Dynamic status

	Bit 7	Bit 6	Bit 5	Bit 4	Bit 3	Bit 2	Bit 1	Bit 0
Byte 0	OutOf Range	Standstill	Inside ZSR	Center Zero	Below Zero	Overload	Above Max	ADU Error
Byte 1				E9	E6	E1	E3	E7
Byte 2						PowerFail	Action Active	CmdError
Byte 3						Tare Active	Cal Changed	Test Active

Note:

Byte 0 corresponds to byte 7 in the output area. Weight error in byte 1, see table in Chapter [16.1](#).

Field	Function
ADUError	AD conversion error (OR function of bits E1, E3, E7).
AboveMax	The weight value has exceeded the Max (FSD), but is still within Max + permissible overload (gross \leq FSD+overload).
Overload	The weight value has exceeded the measuring range. No valid weight data is specified (gross $>$ FSD+overload); error 2 .
BelowZero	The weight value is negative (gross $<$ 0d).
CenterZero	The weight value is within center zero (0 ± 0.25 d)
InsideZSR	The gross weight value is within the zero setting range.
Standstill	The scale is stable.
OutOfRange	Below zero or above max. (FSD).
E7	The measuring signal is negative (inverse conversion); error 7
E6	Sense voltage not present or too low; error 6
E3	The measuring signal is >36 mV (no end of conversion); error 3
E1	Arithmetic error (overflow); error 1
E9	No communication with xBPI scale; error 9
CmdError	Error during execution (CmdError); e.g., the "taring" operation is not processed, because the scale is not at a standstill. The error is stored in LastError (function number 4). The bit is reset with the ResetError bit (function number 121, see Chapter 12.2.5.13).
ActionActive	The device is busy executing a function (e.g., waiting for downtime for taring).
PowerFail	Power failure; is always set after power on. The PowerFail bit is reset with the ResetPWF bit (function number 85, see Chapter 12.2.5.12) "Reset power failure".
Test_Active	The device executes the ADC test. The read weight value is not the gross value, but the test value.
Cal_Changed	The device has been calibrated. When this bit is 1, the weighing parameters (EXPO/UNIT/STEP) must be read again. Set after "Power on" and reset after reading the FSD (Full scale deflection).
Tare_Active	The scale has been tared.

12.2.5.3 Function number 2: For internal use only.**12.2.5.4 Function number 3: For internal use only.****12.2.5.5 Function number 4: calibration information, error byte (read)**

Byte	Description
0: EXPO	One byte for the position of the decimal point; content in decimal form: 0 to 255.
	0 = 000000
	1 = 00000.0
	2 = 0000.00
	3 = 000.000
	4 = 00.0000
	5 = 0.00000
1: UNIT	One byte for the weight unit; content in decimal form: 0 to 255
	1 = mg (milligrams)
	2 = g (grams)
	3 = kg (kilograms)
	4 = t (tons)
	5 = lb (pounds)
	9 = oz (ounces)
2: STEP	One byte for the scale interval; content in decimal form: 0 to 255
	1 = scale interval "1"
	2 = scale interval "2"
	5 = scale interval "5"
	10 = scale interval "10"
	20 = scale interval "20"
	50 = scale interval "50"
3: LASTERROR	Last error byte; see also CmdError bit, number of LASTERROR:
	8 = no standstill was achieved (e.g., when taring).
	13 = zero setting is not possible. The scale has been tared.
	18 = negative weight value when taring and W&M mode on.
	147 = no zero setting; weight not within zero setting range.
	255 = general command error

Note:

Other error nos are possible.

12.2.5.6 Function number 5: device type and software version (read)

	Bit 7	Bit 6	Bit 5	Bit 4	Bit 3	Bit 2	Bit 1	Bit 0
Byte 0	TYPE MSB							
Byte 1	TYPE LSB							
Byte 2	MAINVERSION							
Byte 3	SUBVERSION							

e.g.: PR 5230 Rel 1.23 = 52300123_{hex}

12.2.5.7 Function number 6: serial number of the weighing point (read)

	Bit 7	Bit 6	Bit 5	Bit 4	Bit 3	Bit 2	Bit 1	Bit 0
Byte 0	Serial number MSB							
Byte 1	Serial number							
Byte 2	Serial number							
Byte 3	Serial number LSB							

e.g.: 148388723 = 08D83B73_{hex}

12.2.5.8 Function number 7: For internal use only.**12.2.5.9 Function number 8 to 22: weight data (read)**

The gross, net, and tare weight are stored as a DINT fix point. The real data value is derived from DINT and EXPO as follows:

$$\text{Value}_{\text{Real}} = \text{reading}_{\text{DINT}} \times 10^{(-\text{EXPO})}$$

Function number 8	Current gross value
Function number 9	Current net value, if tared; otherwise gross
Function number 10	Current tare value, if tared; otherwise 0
Function number 11	Current gross/net weight selected with bit 72.
Function number 12	Current gross value in internal resolution (1/100d)
Function number 13	Current tare value in internal resolution (1/100d)
Function number 14	Max (Full scale deflection)
Function number 15	Reserved for internal use.
Function number 16	Print gross weight.
Function number 17	Print net weight.
Function number 18	Print tare weight.
Function number 19	Print sequence number.
Function number 21	Print date
Function number 22	Print time.

12.2.5.10 Function number 24–29: Limit value (Read/Write)

Function number 24	Limit 1 on
Function number 25	Limit 1 off
Function number 26	Limit 2 off
Function number 27	Limit 2 off
Function number 28	Limit 3 on
Function number 29	Limit 3 off

12.2.5.11 Function number 30, 31: Fixed values (Read/Write)

Function number 30	Fixed value for analog output, value (num) 0...20000 corresponds to 20 mA
Function number 31	Fixed value for preset tare, see also SetFixTare , GetFixTare in Chapter 12.2.1 .

12.2.5.12 Function number 80–89: state-controlled action bits (write)**Note:**

For setting bits, see Chapter [12.2.2.3](#).

Only setting and resetting of single bits is possible.

When changing a bit from 0 to 1, the corresponding action starts. After handling the command, the bit must be reset. Application: The master writes cyclically.

The bit is set as **Write_Value_Select** with the specified number (see Chapter [12.2.2.3](#)).

The bit is reset at the specified number +128.

Function number 80	SetZero	Set the gross weight to zero.
Function number 81	SetTare	The weighing point is tared.
Function number 82	ResetTare	Reset tare.
Function number 83	SetTest	Start the ADC test.
Function number 84	ResetTest	Finish the ADC test.
Function number 85	ResetPwf	Reset the PowerFail bit (function number 1; the bit was set after "power on").
Function number 86	SetFixTare	Taring with weight in numerical address D31 "FixTare".
Function number 87	GetFixTare	The current gross weight is copied to the numerical address D31.
Function number 89	ResetError	The CmdError error bit is reset.

12.2.5.13 Function number 112–119, 121: transition-controlled action bits (write)

For setting bits, see Chapter [12.2.2.3](#).

As soon as the bit has been set, it is reset internally and the process is carried out; this process is transition-controlled (for one write operation).

The bit is set as **Write_Value_Select** with the specified number (see Chapter [12.2.2.3](#)).

Function number 112	SetZero
Function number 113	SetTare
Function number 114	ResetTare
Function number 115	SetTest
Function number 116	ResetTest
Function number 117	ResetPwf
Function number 118	SetFixTare (function number 86, see Chapter 12.2.5.12).
Function number 119	GetFixTare (function number 87, see Chapter 12.2.5.12).
Function number 121	ResetError

Note:

To prevent frequent writing to the EAROM, the write interval should be no shorter than 15 seconds.

12.2.6 Example: reading the gross weight

Input range (MOSI)

Byte	Value	Description
0		
1		
2		
3		
4	08	Read the gross weight (for function number 8, see Chapter 12.2.5.9)
5		
6		
7		

Output range (MISO)

Byte	Value	Description
0	00	Gross weight - byte 0 (MSB)
1	00	Gross weight - byte 1

Byte	Value								Description
2	04								Gross weight - byte 2
3	D2								Gross weight - byte 3 (LSB)
4	08								Gross weight request detected.
5	Write Active	Power Fail							In direct access, status bits are independent of the write or read request.
6	Cmd Busy	Cmd Error			Tare Active	Cal Active	Test Active		
7	OutOf range	Stand- still	Inside ZSR	Center Zero	Below Zero	Over- load	Above Max	ADU Error	
	Bit 7	Bit 6	Bit 5	Bit 4	Bit 3	Bit 2	Bit 1	Bit 0	

The gross value (hex:000004D2 <=> 1234) can be read from bytes 0...3.
Negative values are output in the second complement.

12.2.7 Special note for DeviceNet and EtherNet IP

With these fieldbus types, the sequence of the bytes (only applicable for words and individual bytes) is inverted.

With long words, this problem does not arise due to compensation by the firmware.

Sequence of data bytes 0...3:

Standard sequence		Sequence for DeviceNet and EtherNet-IP	
Byte 0	Read data 0 (MSB)	Byte 0	Read data 3 (LSB)
Byte 1	Read data 1	Byte 1	Read data 2
Byte 2	Read data 2	Byte 2	Read data 1
Byte 3	Read data 3 (LSB)	Byte3	Read data 0 (MSB)

Consequently, the sequence on the PLC side must be changed when using the "DeviceNet" and "EtherNet IP" fieldbus types.

12.3 Filling protocol (64-Byte) for the "EasyFill" application

The "EasyFill" application uses a 64-byte interface.

The 8-byte scale protocol for the "Standard" application is not available.

12.3.1 Write window (input area)

Data are transferred from the master (PLC) to the slave (PR 5230) in this window.

12.3.2 Read window (output area)

Data are transferred from the slave (PR 5230) to the master in this window.

The data required for monitoring and controlling filling does not fit in a 64-byte write window. For this reason the system differentiates between system and material parameters. The value of the first byte can be used to determine whether the data refers to the system or the material.

12.3.3 Indicator functions

E.g., gross, net, tare; all indicator statuses and commands are available at the same time. In contrast to the 8-byte interface, in the 64-byte interface the parameters, statuses, and values are all available simultaneously.

Some values may be output as data type DINT or REAL depending on write bit 2 in byte 2.

12.3.4 Filling functions

12.3.4.1 Filling start

12.3.4.1.1 General information

There are two ways to carry out filling:

- (A) Filling parameters are written at each start by the PLC.
- (B) Filling parameters are stored in the device (PR 5230).

Requirements:

The system is ready.

The device has been checked to ensure it is ready for the start of filling. It is ready when no filling is currently taking place and no parameters are being changed.

This status is signaled by bit 2 (Ready) in byte 3.

12.3.4.1.2 Filling start A

The material parameters can be found in the PLC.

1. Write the material parameters.
 - Set point
 - Preset
 - Material overshoot (OVS)
 - Tolerance above/below set point
 - Calming time

2. Set start bit:

Byte 1

These parameters are applied with the rising edge of the start bit. If the parameters are valid, the filling process is started and the Dosing_Run bit is set.

The end of the filling process is signaled by the falling edge of the Dosing_Run bit.

12.3.4.1.3 Filling start B

The material parameters can be found in the device material table (PR 5230).

1. Write the material ID to byte 3.
2. Set start bit:

0000 1000 in byte 1

12.3.4.2 Filling control

12.3.4.2.1 Pausing filling

Requirements:

The system is filling, i.e.,

- the Dosing_Run bit is active
- and
- the hold bit is not active

Example:

Set stop bit with 0100 0000 in byte 1.

Filling stops with the rising edge and the system goes to the hold status (hold state).

If the system is in hold state, filling can be restarted or canceled.

12.3.4.2.2 Restarting filling

Requirements:

The system stops, i.e., the Hold_state bit is active.

Example:

Set stop bit with 0010 0000 in byte 1.

Filling starts again with the rising edge and the system leaves the hold status (hold state) and continues filling.

12.3.4.2.3 Canceling filling

Requirements:

The system stops, i.e., the Hold_state bit is active.

Example:

Set cancel bit with 0001 0000 in byte 1.

Filling starts again with the rising edge and the system leaves the hold status (hold state) and goes back to the ready status (ready/idle).

12.3.4.3 Filling report

The filling results are stored after filling and only overwritten when there is a new result.

12.3.4.4 Filling error

Last_Error

The last error number is retained until it is reset.

The possible error numbers are listed in Chapter [16.8.2](#).

12.3.4.5 Reading the material table

The material parameters can be read from the material table of the device (PR 5230).

Procedure:

1. Write the material ID to byte 3.
2. Write command 1 to byte 0 in order to see the material parameters on the read side.
3. Write command 0000 0001 to byte 2 in order to copy the material parameters from the material table.
 - ▷ If all parameters of the material were available to be read, 1000 0000 is set to byte 2.

4. Write command 0 to byte 0 in order to see the filling parameters again on the read side.

12.3.5 Setup of the fieldbus interface

For description of the data types see Chapter [13.2](#).

12.3.5.1 PLC → write window EasyFill

Bytes 0...63	Name	Type of data	Function
Byte 0	TableSelect	USINT	The first byte controls (multiplexes) the data written in the read window by the device. A "0" describes the read window according to the system data layout. A "1" copies the material data to the read window.
Byte 1 Bit 0: MSB	Bit 0: start filling Bit 1: stop filling Bit 2: restart filling Bit 3: cancel filling Bit 4: load material and start filling Bit 5: print last filling result Bit 6: reserved Bit 7: reserved	BOOL	<p>Bit 0: EasyFill adopts the sent material parameters from byte 4 with the rising edge of this bit. A valid set point (byte 4...7) that can be coded as DINT or REAL is required. The filling process can be started when the ready bit is set.</p> <p>Bit 1: rising edge during filling</p> <p>Bit 2: rising edge in the stop status (hold state)</p> <p>Bit 3: rising edge in the stop status (hold state)</p> <p>Bit 4: rising edge: A valid material ID is required in byte 3.</p> <p>Bit 5: rising edge: The printout of the last filling result starts.</p>

Bytes 0...63	Name	Type of data	Function
Byte 2	Bit 0: reset power failure (power fail) Bit 1: reset error Bit 2: weights as DINT Bit 3: zero Bit 4: tare Bit 5: reset tare Bit 6: filling mode Bit 7: read material from the material table	BOOL	Bit 0: rising edge Bit 1: rising edge: resets the error flag and error code. Bit 2: status-controlled: Value: 0 = Real, 1 = DINT Bit 3: rising edge Bit 4: rising edge Bit 5: rising edge Bit 6: status-controlled: 0 = fill, 1 = empty Bit 7: rising edge: A valid material ID is required in byte 3. Filling does not start. This function can be used to display material parameters on external displays.
Byte 3	Material ID	BYTE	Value range: 1...10
Byte 4...7	Set point	DINT/REAL	Weight
Byte 8...11	Preset	DINT/REAL	Preset point for switching from coarse flow to fine flow.
Byte 12...15	Material overshoot (OVS)	DINT/REAL	Weight
Byte 16...19	Calming time	DINT	[ms]
Byte 20...23	Tolerance above set point	DINT/REAL	Weight
Byte 24...27	Tolerance below set point	DINT/REAL	Weight

12.3.5.2 Read window EasyFill → PLC

The data required for monitoring and controlling filling does not fit in a 64-byte write window. For this reason the system differentiates between system and material parameters. The value of the first byte can be used to determine whether the data refers to the system or the material.

12.3.5.2.1 System data

Before starting filling, a check must be carried out to ensure that the system is ready (byte 3: bit 2).

The Dosing_Run bit is set once filling has successfully started.

Bytes 0...63	Name	Type of data	Function
Byte 0	TableSelect	USINT	Content of read data: 0 = system data, 1 = material data

Bytes 0...63	Name	Type of data	Function
Byte 1 Bit 0: MSB	Bit 0: ADC error Bit 1: above max. + still permissible range (OVL) Bit 2: above max. (FSD) Bit 3: below zero Bit 4: zero $\pm 1/4$ d Bit 5: within zero set range (ZSR) Bit 6: weight is stable Bit 7: weight above max. (FSD) and below overload	BOOL	
Byte 2	Bit 0: read material data valid Bit 1: change calibration Bit 2: tare Bit 3: reserved Bit 4: reserved Bit 5: power failure (power fail) Bit 6: within menu [Set-up]/[Configuration] Bit 7: filling mode	BOOL	Bit 0: The material data is available. Bit 1: Calibrate weighing point. Bit 2: Set tare of the instrument. Bit 5: After a power failure the bit is set and can be reset by bit 0 in byte 2. Bit 6: Filling is not possible within the menu items. Bit 7: status-controlled: 0 = fill, 1 = empty
Byte 3	Bit 0: error in the application Bit 1: filling is active Bit 2: system ready Bit 3: filling stopped Bit 4: coarse flow Bit 5: fine flow Bit 6: calming time Bit 7: tolerance alarm	BOOL	Bit 0: Error bit is set if any action has failed. We recommend evaluating the error bit (Appl_Error) and the detailed error code in byte 63 after each action. Bit 1: The filling phase is active. Bit 2: The system is ready for filling. Bit 3: Filling was stopped. Bit 4: System is filling: coarse flow bit is set. Bit 5: System is filling: fine flow bit is set. Bit 6: The bit is set according to the set calming time. Bit 7: alarm if tolerance is above/below set point
Byte 4...7	Gross	DINT/REAL	Weight
Byte 8...11	Net	DINT/REAL	Weight
Byte 12...15	Tare	DINT/REAL	Weight

Bytes 0...63	Name	Type of data	Function
Byte 16...19	Max. weight (FSD)	DINT/REAL	Weight
Byte 20...23	Min. weight	DINT/REAL	Weight
Byte 24...27	Scale interval	DINT/REAL	Weight
Byte 28	Exponent	USINT	Number of decimal places Example: 1.23 is displayed Exponent: 2
Byte 29...30	Unit	STRING_2	Unit in plain text "t", "kg", "g", "mg", "lb", "oz"
Byte 31	Reserved		
Byte 32...35	Gross filling result	DINT/REAL	The filling results are stored after filling and only overwritten when there is a new result.
Byte 36...39	Tare filling result	DINT/REAL	
Byte 40...43	Net filling result	DINT/REAL	
Byte 44...47	Set point filling result	DINT/REAL	
Byte 48...51	Date of filling result	DINT	Example: 20161116h corresponds to November 16, 2016
Byte 52...55	Time of filling result	DINT	Example: 14153199h corresponds to 14:15:31 and 99 ms
Byte 56...59	Sequence number of filling result	DINT	Sequential number
Byte 60	Filling result status	BYTE	1 = successful, 2 = tolerance alarm, 3 = canceled
Byte 61...62	Reserved		
Byte 63	"Last_Error" error		The last error number is retained until it is reset (for possible errors see Chapter 16.8.2).

12.3.5.2.2 Material data

The first 15 bytes and byte 63 (Last_Error) correspond to the layout of the system data.

Bytes 0...63	Name	Type of data	Function
Byte 0	TableSelect	USINT	Content of read data: 0 = system data, 1 = material data

Bytes 0...63	Name	Type of data	Function
Byte 1 Bit 0: MSB	Bit 0: ADC error Bit 1: above max. + still permissible range (OVL) Bit 2: above max. (FSD) Bit 3: below zero Bit 4: zero $\pm 1/4$ d Bit 5: within zero set range (ZSR) Bit 6: weight is stable Bit 7: weight above max. (FSD) and below overload	BOOL	
Byte 2	Bit 0: trigger material data reading Bit 1: change calibration Bit 2: tare Bit 3: reserved Bit 4: reserved Bit 5: power failure (power fail) Bit 6: within menu [Set-up]/[Configuration] Bit 7: filling mode	BOOL	Bit 0: Reading of material data was triggered by the fieldbus. Bit 1: Calibrate weighing point. Bit 2: Set tare of the instrument. Bit 5: After a power failure the bit is set and can be reset by bit 0 in byte 2. Bit 6: Filling is not possible within the menu items. Bit 7: status-controlled: 0 = fill, 1 = empty
Byte 3	Bit 0: error in the application Bit 1: filling is active Bit 2: system ready Bit 3: filling stopped Bit 4: coarse flow Bit 5: fine flow Bit 6: calming time Bit 7: tolerance alarm	BOOL	Bit 0: Error bit was set. Bit 1: The filling phase is active. Bit 2: The system is ready for filling. Bit 3: Filling was stopped. Bit 4: System is filling: coarse flow bit is set. Bit 5: System is filling: fine flow bit is set. Bit 6: The bit is set according to the set calming time. Bit 7: alarm if tolerance is above/below set point
Byte 4...7	Gross	DINT/REAL	Weight
Byte 8...11	Net	DINT/REAL	Weight
Byte 12...15	Tare	DINT/REAL	Weight
Byte 16	Material ID	BYTE	Current material ID

Bytes 0...63	Name	Type of data	Function
Byte 17	Reserved		
Byte 18...35	Material name	STRING_18	Current material name
Byte 36...39	Set point	DINT/REAL	Current set point
Byte 40...43	Preset	DINT/REAL	Current set point
Byte 44...47	Material overshoot (OVS)	DINT/REAL	Current set point
Byte 48...51	Calming time	DINT	Current set point
Byte 52...55	Tolerance above set point	DINT/REAL	Current set point
Byte 56...59	Tolerance below set point	DINT/REAL	Current set point
Byte 60...62	Reserved		
Byte 63	"Last_Error" error		The last error number is retained until it is reset (for possible errors see Chapter 16.8.2).

13 SPM

13.1 General information

The memory accessible to the user is the SPM (Scratch Pad Memory). This memory is used to store lots of internal data from which weights, statuses and reports can be read and control data can be written.

The SPM table can be accessed via OPC and ModBus communication and fieldbus with SPM interface.

In addition, individual bits are copied back and forth between digital inputs and outputs and the SPM via the I/O configuration.

Note:

If a text is defined e.g. from SPM address B401, this must be defined in the OPC server from SPM address B400 so that the content actually begins at B401.

13.2 Elementary data types

The elementary data types are characterized by their bit width and possible value range. All commands of the data type BOOL are executed with a rising edge.

Data type	Description	Value range
BOOL	bool	0 (FALSE) or 1 (TRUE)
SINT	short integer	-128 to 127
INT	integer	-32768 to 32767
DINT	double integer	-2^{31} to $2^{31}-1$
LINT	long integer	-2^{63} to $2^{63}-1$
USINT	unsigned short integer	0 to 255
UINT	unsigned integer	0 to 65535
UDINT	unsigned double integer	0 to $2^{32}-1$
ULINT	unsigned long integer	0 to $2^{64}-1$
REAL	real number	$\pm 1.18\text{E}-38$ bis $3.4\text{E}38$ (with approx. 7 significant digits)
LREAL	long real number	$\pm 1.18\text{E}-308$ bis $3.4\text{E}308$ (with approx. 16 significant digits)
TIME	time duration	1 ms to $\pm 2^{47}$ ms
DATE	date (only)	1.1.1900 to 31.12.2099
TIME_OF_DAY	time of day (only)	00:00:00.00 to 23:59:59.99
DATE_AND_TIME	Date and time of day	see DATE and TIME_OF_DAY
STRING	variable-long character string	max. 255 characters (ISO)

Data type	Description	Value range
WSTRING	variable-long wide character string	max. 255 characters (Unicode)
BYTE	bit-sequence 8	...
WORD	bit-sequence 16	...
DWORD	bit-sequence 32	...
LWORD	bit-sequence 64	...

13.3 Addressing

The SPM table can be addressed via different counts. Bit addressing is used to count the individual bits (MX). Byte addressing is used to count individual bytes (MB), whereby, e.g. bits MX0...MX7 are identical to byte MB0.

Code	Data type	Address example
%ML	LWORD	L21
%MD	DINT	D42...43
%MW	WORD	W84...87
%MB	BYTE	B168...175
%MX	BOOL (bit)	X1344...1407

13.4 System data

SPM address	Data type	R/W	Function
X0...X2	BOOL	R	Digital input 1...3
X8...10	BOOL	R	Digital output 1...3
X16...18	BOOL	R	Standard only: Output limit 1...3
B4	BYTE	R	Indicator status
X32	BOOL	R	ADC error
X33	BOOL	R	> Max (FSD = Full Scale Deflection)
X34	BOOL	R	> Max + permitted range (OVL)
X35	BOOL	R	< zero
X36	BOOL	R	Zero $\pm 1/4$ d
X37	BOOL	R	Within the zeroset range (ZSR)
X38	BOOL	R	The weight is stable
X39	BOOL	R	Weight < zero or > Max (FSD = Full Scale Deflection)

SPM address	Data type	R/W	Function
B5	BYTE	R	ADC status
X40	BOOL	R	Measuring signal negative (error 7)
X41	BOOL	R	Measuring signal >36 mV (error 3)
X42	BOOL	R	Internal arithmetic error; CAL data are perhaps faulty (error 1)
X43	BOOL	R	No or too low sense voltage (error 6)
X44	BOOL	R	No communication with xBPI scale (error 9)
B6	BYTE	R	Command status
X48	BOOL	R	Command error
X49	BOOL	R	Command active
X50	BOOL	R	Network failure signal
B7	BYTE	R	Active status
X56	BOOL	R	Test mode active
X57	BOOL	R	Calibration active
X58	BOOL	R	Instrument is tared
X59	BOOL	R	Pendeo only: parameter [Unbal. check deviat.]
X60	BOOL	R	Pendeo only: operation with a simulated load cell
X64	BOOL	R/W	Standard only: Read/write marker bit 1
X65	BOOL	R/W	Standard only: Read/write marker bit 2
X66	BOOL	R/W	Standard only: Read/write marker bit 3
X72	BOOL	R/W	Switch D11 to net weight.
X112	BOOL	W	Zero device.
X113	BOOL	W	Tare device
X114	BOOL	W	Reset the tare of the device
X115	BOOL	W	Start the test mode
X116	BOOL	W	Finish the test mode
X117	BOOL	W	Reset the power fail signal
X118	BOOL	W	Set fixed tare weight D31 as tare
X119	BOOL	W	Store the current gross weight in the preset tare memory (D31)
X120	BOOL	W	EasyFill only: Start printout. Standard only: Weight report
X121	BOOL	W	Reset error B19 = 0.
X123	BOOL	W	Read out current time and date.
X124	BOOL	W	Save (set) current time and date.
B16	SINT	R	Exponent Number of decimal places Example: 1.23 is displayed Exponent: 2
B17	SINT	R	Weight unit 1 = mg, 2 = g, 3 = kg, 4 = t, 5 = lb, 9 = oz

SPM address	Data type	R/W	Function
B18	SINT	R	Verification interval (for multi-interval/multi-range = d1 or e1)
B19	BYTE	R	Last weighing point error, see Chapter 16.8.1 .
B20	BYTE	R	Higher byte of product code (0x52)
B21	BYTE	R	Lower byte of product code (0x30)
B22	BYTE	R	Major part of version number (1.0)
B23	BYTE	R	Minor part of version number (1.0)
D6	UDINT	R	Serial number (board number)
W14	INT	R	Counter will be increased for every measured value.
D8	DINT	R	Current gross weight
D9	DINT	R	Current net weight
D10	DINT	R	Current tare weight
D11	DINT	R	Current gross/net weight selected with X72
D14	DINT	R	Max weight (FSD = Full Scale Deflection)
D15	DINT	R	Min weight
D16	DINT	R	Report: Gross weight
D17	DINT	R	Report: Net weight
D18	DINT	R	Report: Tare weight
D19	DINT	R	Report: Sequence number
D21	DINT	R	Report: Date
D22	DINT	R	Report: Time
D23	DINT	R	Activity counter, test of communication with device
D24	DINT	R	Standard only: Limit: Limit 1 on
D25	DINT	R	Standard only: Limit: Limit 1 off
D26	DINT	R	Standard only: Limit: Limit 2 on
D27	DINT	R	Standard only: Limit: Limit 2 off
D28	DINT	R	Standard only: Limit: Limit 3 on
D29	DINT	R	Standard only: Limit: Limit 3 off
D30	UDINT	R/W	Standard only: Analog output for "transparent" mode
D31	DINT	R/W	Preset tare memory (X118, X119)
B128...143	BYTE	R/W	Configure device display

SPM address	Data type	R/W	Function
B144	BYTE	R	EasyFill only: Batching status 1
X1152	BOOL	R	Batching active
X1153	BOOL	R	Batching ready (ready/idle)
X1154	BOOL	R	Batching is in error state
X1155	BOOL	R	The setup menu of the scale is active.
B145	BYTE	R	EasyFill: Batching status 2
X1160	BOOL	R	Batching in progress
X1161	BOOL	R	Batching stopped
X1162	BOOL	R	Coarse flow
X1163	BOOL	R	Fine flow
X1164	BOOL	R	Calming
X1165	BOOL	R	Tolerance alarm
B146	BYTE	W	EasyFill only: Batching command 1
			Start batching with the current record:
X1168	BOOL	W	Start/Restart
X1169	BOOL	W	Stop/Cancel
			Load a defined material and start in one step:
X1170	BOOL	W	Start ID 1
X1171	BOOL	W	Start ID 2
X1172	BOOL	W	Start ID 3
X1173	BOOL	W	Start ID 4
X1174	BOOL	W	Start ID 5
X1175	BOOL	W	Start ID 6
B147	BYTE	W	EasyFill only: Batching command 2
X1176	BOOL	W	Start ID 7
X1177	BOOL	W	Start ID 8
X1178	BOOL	W	Start ID 9
X1179	BOOL	W	Start ID 10
X1180	BOOL	W	Print report
X1181	BOOL	W	Reset error status D67 = 0
B148	BYTE	W	EasyFill only: Batching command 3
X1182	BOOL	W	Load selected material
X1183	BOOL	W	Save selected material
B149	BYTE	R/W	EasyFill only: Batching modes (1 = B1; 4 = B4)
W76	DINT	R/W	EasyFill only: Material ID
B156...173	BYTE	R/W	EasyFill only: Material name for ID1...10
D44	DINT	R/W	EasyFill only: Set point
D45	DINT	R/W	EasyFill only: Preset
D46	DINT	R/W	EasyFill only: Material overshoot (OVS)
D47	DINT	R/W	EasyFill only: Calming time [ms]
D48	DINT	R/W	EasyFill only: Tolerance below set point
D49	DINT	R/W	EasyFill only: Tolerance above set point

SPM address	Data type	R/W	Function
W104 (B209)	WORD	R	EasyFill only: Report: Material ID
B212...229	BYTE	R	EasyFill only: Report: Material name
D58	DINT	R	EasyFill only: Report: Batched weight
D59	DINT	R	EasyFill only: Report: Set point
D60	DINT	R	EasyFill only: Report: Preset
D61	DINT	R	EasyFill only: Report: Material overshoot (OVS)
D62	DINT	R	EasyFill only: Report: Calming time [ms]
D63	DINT	R	EasyFill only: Report: Tolerance below set point
D64	DINT	R	EasyFill only: Report: Tolerance above set point
D67	DINT	R	EasyFill only: "Last_Error" error, see Chapter 16.8.2
OPC server only			
R264	REAL	R	Gross weight (as floating point number)
R265	REAL	R	Net weight (as floating point number)
R266	REAL	R	Tare weight (as floating point number)
R267	REAL	R	Current gross/net weight selected with X72 (as floating point number)
R270	REAL	R	Max weight (FSD = Full Scale Deflection) (as floating point number)
R271	REAL	R	Min weight (as floating point number)
R272	REAL	R	Report: Gross weight (as floating point number)
R273	REAL	R	Report: Net weight (as floating point number)
R274	REAL	R	Report: Tare weight (as floating point number)
R280	REAL	R	Standard only: Limit: Limit 1 on (as floating point number)
R281	REAL	R	Standard only: Limit: Limit 1 off (as floating point number)
R282	REAL	R	Standard only: Limit: Limit 2 on (as floating point number)
R283	REAL	R	Standard only: Limit: Limit 2 off (as floating point number)
R284	REAL	R	Standard only: Limit: Limit 3 on (as floating point number)
R285	REAL	R	Standard only: Limit: Limit 3 off (as floating point number)
R287	REAL	R/W	Write the value in the preset tare memory (as floating point number).
L17	LWORD	W	SPM out
X1088...1151	BOOL	R	Output
L18	LWORD	W	SPM out AND coarse
X1152...1215	BOOL	R	Output and coarse
L19	LWORD	W	SPM out AND fine
X1216...1279	BOOL	R	Output and fine

Note:

The system variables (e.g. ST_WGT_A) for communication via OPC are described in operating instructions PR 1792 (Chapter 4 + 5).

Example:

Production start

Write material parameters (D44...D49).

Start batching (X1168).

Monitor status (B144, B145).

Once batching is complete, read report data.

14 Maintenance/repairs/soldering work/cleaning

14.1 Maintenance

Maintenance work may only be carried out by a trained technician with expert knowledge of the hazards involved and the required precautions.

14.2 Repairs

Repairs are subject to inspection and must be carried out at Minebea Intec.

In case of defect or malfunction, please contact your local Minebea Intec dealer or service center for repair.

When returning the device for repair, please include a precise and complete description of the problem.

14.2.1 Battery for date/time

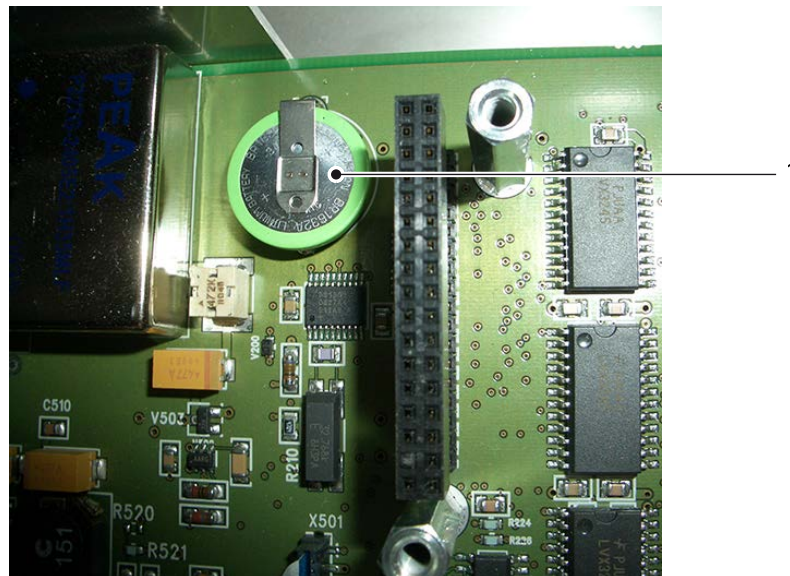

The lithium battery (1) for backing up the calendar/time chip is located beside the power supply on the main board.

The lithium battery for backing up the calendar/time chip is located on the main board. The battery is activated before the device leaves the factory.

Note:

After initial start-up, the date and time must be checked and set if necessary under  - [Date&Time].

14.2.2 Changing the battery for date/time

The device is equipped with a lithium battery for backing up the time/calendar chip. If the voltage drops below the specified minimum, or in case of defect, the battery must be replaced by Minebea Intec customer service or by an equivalent trained technician.

The battery is activated by setting the date and time under  - [Date&Time].
For disposal information, see Chapter [15](#).

For battery lifespan, see Chapter [17.3.1](#).

14.3 Soldering work

Soldering work on the device is neither required nor permitted.

14.4 Cleaning

NOTICE

Property damage caused by unsuitable cleaning utensils/agents.

Damage to the device.

- ▶ Prevent moisture from penetrating the interior.
 - ▶ Do not use aggressive cleaning agents (solvents or similar agents).
 - ▶ For use in the food industry, use a cleaning agent suitable for that particular working environment.
 - ▶ Use soft sponges, brushes and cloths.
 - ▶ Spraying with water or blasting with compressed air is not permitted.
-

1. Unplug device from mains supply, disconnect any data cables.
2. Clean the device with a cloth lightly moistened with a soap solution.
3. Wipe down the device with a soft, dry cloth after cleaning.

15 Disposal

Our products and their packaging should not be disposed of in municipal waste (e.g. garbage can for recyclable packaging, garbage can for paper packaging, etc.). They can either be recycled by the customer themselves, providing this complies with requirements set out by electrical or electronic waste or packaging waste laws, or sent back to Minebea Intec at a charge.

This option of returning the product is intended to provide proper recycling or reuse in a manner that is collected separately from municipal waste.

Before disposing of or scrapping the old products, any single-use or rechargeable batteries should be removed and taken to a suitable collection point. The type of battery used is specified in the technical data.

Please see our General Terms and Conditions for further information.

Service addresses for repair acceptance and collection points can be found on the product information enclosed with the product as well as on our website (www.minebea-intec.com).

Should you have any further questions, please contact your local service representative or our service center.

Minebea Intec GmbH

Repair center

Meiendorfer Strasse 205 A

22145 Hamburg, Germany

Phone: +49.40.67960.333

service.HH@minebea-intec.com

We reserve the right not to accept products that are contaminated with hazardous substances (ABC contamination).

16 Error messages

16.1 Error messages measuring circuit

The internal weighing electronics can generate error messages, which are shown on the weight display.

Display	VNC text	Error and possible cause
E:Arith	Arith. error	Internal arithmetic overflow: - Faulty calibration values.
E:Overl	Overload	The measuring signal is higher than Max + (x d): - Wrong setting. - Too much weight on the scale.
E:NoSig	Ext. meas. device error	Measuring input open: - The measuring signal is higher than the permissible range of 36 mV. - Measuring cable is interrupted (cable break detection). - Other hardware defect.
E:Under	Value exceeds display	The weight value is not displayed: - Too many digits have been set.
E:Sense *	No sense voltage	No sense voltage: - Load cells not connected. - Sense line or supply line is interrupted. - Wrong polarity or sense voltage is low.
E:Invers	Negative input	Negative measuring signal: - Wrong polarity of load cell signal. - Wrong polarity of load cell supply voltage.
E:HardE	No values from scale	Internal weighing point: The measuring signal is higher than the permissible range of 36 mV. Cannot read weight values from ADC (analog-digital converter). - Error in weighing electronics board. - Defective load cell. - Cable break.



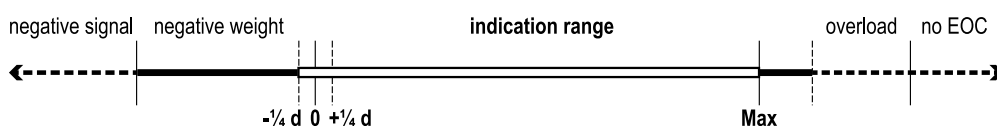



* with Ex applications strictly see Chapter [16.7](#).



16.2 Weight error status

Note:

VNC text, see also Chapter [16.1](#).

LED	E:Arith	E:Invers	E:Overl	E:NoSig	E:Sense	E:HardE/E:NoCom
	Flash. 1Hz	Flash. 1Hz			Altern. flash. 1Hz	Altern. flash. 1Hz
	Flash. 1Hz			Flash. 1Hz	Altern. flash. 1Hz	
	Flash. 1Hz	Flash. 1Hz	Flash. 1Hz	Flash. 1Hz	Altern. flash. 1Hz	Altern. flash. 1Hz
						
						
						

Note:

In all other messages, the top status LED will flash.

16.3 Error messages for xBPI scales





Display	VNC text	Error and possible cause
E:NoSig	Ext. meas. device error	No weight values can be read from scale: - Scale error
E:Value	Value exceeds display	The weight value is not displayed: - Too many digits have been set.
E:NoCom	No values from scale	No communication with xBPI scale: - Cable break. - Internal scale error. - The scale is not connected to the power supply.
E:NoWgt	No weight data	No weight display: - Another weighing point was selected. Press  to assign the new weighing point to the device.



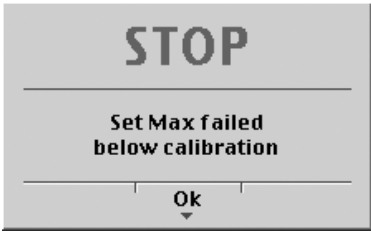

Display	VNC text	Error and possible cause
E:NotRd	Scale not ready	The scale is not ready for weighing: <ul style="list-style-type: none"> - The device is in the warm-up phase. - The device is in automatic taring mode. - The device was switched on with the scale loaded. Switch the device off and on again.
E:BadDev	Wrong serial number	Serial number of scale does not match the number set in the device.

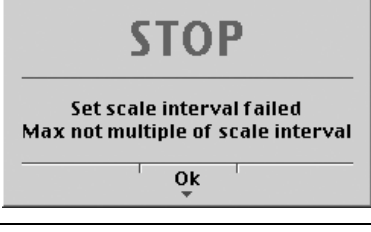
16.4 Error messages for Pendeo load cells

Display	VNC text	Error and possible cause
E:Overl	Overload	The measuring signal is higher than Max + (x d): <ul style="list-style-type: none"> - Wrong setting. - Too much weight on the scale.
E:Value	Value exceeds display	The weight value is not displayed: <ul style="list-style-type: none"> - Too many digits have been set.
E: Units	Incompatible units	Incompatible units: <ul style="list-style-type: none"> - Incorrect calibration values e.g. due to incorrect calibration
E:NoCom	No values from scale	No communication with Pendeo load cell: <ul style="list-style-type: none"> - Cable break. - Internal scale error. - The junction box is not connected to the supply voltage.
E:NotRd	Scale not ready	The scale is not ready for weighing: <ul style="list-style-type: none"> - At least 1 load cell gives an error status or is defective (no communication).
E: Config	Wrong configuration	The number of load cells does not match the configuration.
E:BadDev	Wrong serial number	Serial number of scale does not match the number set in the device.

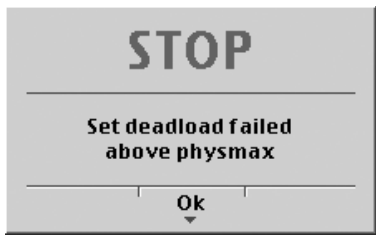
16.5 Error messages during calibration

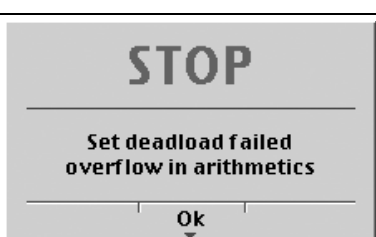
Message	Possible causes
 <p>STOP</p> <p>Set Max failed above physmax</p> <p>Ok</p>	This message displays, if the maximum load is too high.
 <p>STOP</p> <p>Set Max failed below calibration</p> <p>Ok</p>	The maximum load of the scale can be increased retroactively. When the capacity is reduced, however, a message is displayed when the new maximum load is lower than the CAL weight ([Calibrated at]).
 <p>STOP</p> <p>Set Max failed not enough d</p> <p>Ok</p>	This message is displayed if the selected resolution is too low, e.g., 5 kg.
 <p>STOP</p> <p>Set Max failed too many digits</p> <p>Ok</p>	This message is displayed if the selected resolution is so high that less than 0.8 internal counts per scale interval (d) and/or 0.5 $\mu\text{V}/\text{e}$ are available if legal-for-trade acc. to OIML/NSC.
 <p>STOP</p> <p>Set scale interval failed Max not multiple of scale interval</p> <p>Ok</p>	This message displays if the maximum load is not an integer multiple of the scale interval.
 <p>STOP</p> <p>Set Max failed incompatible units</p> <p>Ok</p>	Weight units don't match, e.g., subsequent change for [Max] from kg into lb.

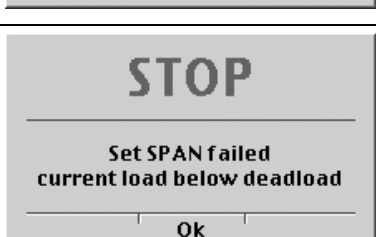
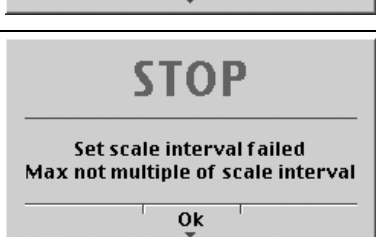
Message	Possible causes
	<p>This message is displayed when the dead load entered in mV/V plus scale interval in mV/V is higher than 3 mV/V (= 36 mV).</p>
	<p>This message displays, if the scale is not stable. Remedy</p> <ul style="list-style-type: none"> - Check the mechanical function of the scale. - Adapt the filter setting; reduce the resolution. - Adapt the standstill conditions.
	<p>This message is displayed when the measurement signal is negative when determining the dead load with [by load]. Cause Load cell connected with wrong polarity, or defective.</p>
	<p>This message is displayed when the dead load entered is >5 mV/V.</p>
	<p>This message displays, if the scale is not stable. Remedy</p> <ul style="list-style-type: none"> - Check the mechanical function of the scale. - Adapt the filter setting; reduce the resolution. - Adapt the standstill conditions.
	<p>This message is displayed if the weight on the scale is $<$ the dead load after input of the weight value.</p>
	<p>The maximum capacity is not an integer multiple of the scale interval.</p>

16.6 General error messages

Display	VNC text	Error and possible cause
	Duplicate ID	The IP address is already in use. Two instruments with identical IP addresses.
	Supply voltage is low!	Supply voltage is too low -15%. Supply voltage is too low ($\leq 85\%$).
E:BadDev*	Wrong serial number	- Weighing electronics board has been changed after calibration. - Device is not calibrated.

* Only if CAL switch is closed.

16.7 Error messages for Ex applications

In the event of load cell supply faults, the following error message is displayed:

E:Sense (via VNC: **No sense voltage**)

Two different faults are possible, which are displayed by two LEDs on the weighing electronics board (WE1).

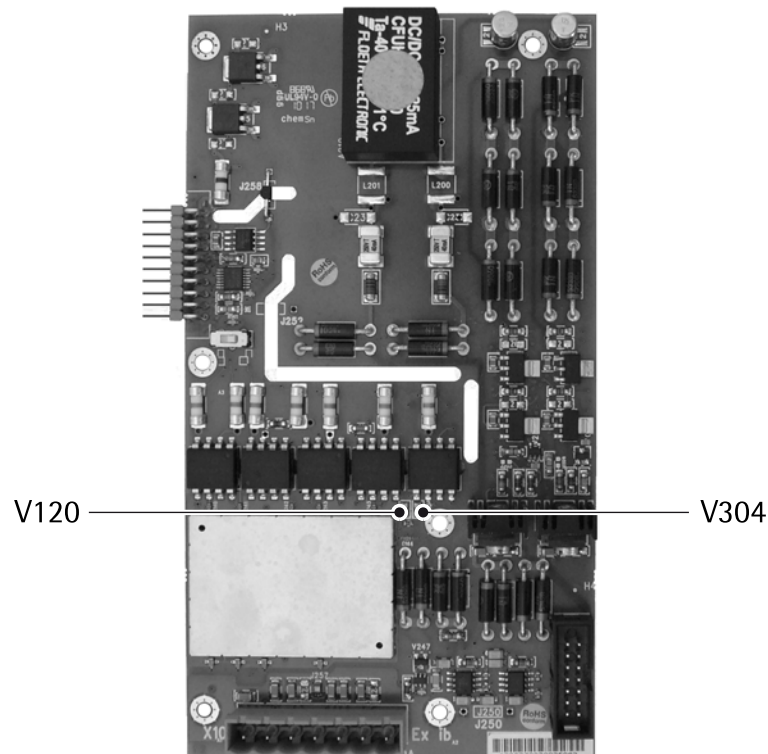

V120 is lit:

The sense voltage is not available or too low.

Cause:

Sense line or supply line is interrupted

V304 is lit:

The current limit for the load cell supply is activated.

Causes:

- There is a short circuit in the load cell supply lines
- The load cell resistance is too low (e.g. too many load cells connected)

Current limiting at >96 mA

WARNING

Working on the device while it is switched on may have life-threatening consequences.

When removing covers or parts using tools, live parts or terminals may be exposed. Please note that capacitors in the device may still be charged even after disconnecting the device from all voltage sources.

- ▶ Disconnecting the device from the power supply.

Disconnect the device from the power supply and eliminate the fault.

After the fault is eliminated it may be necessary to switch off the device and/or disconnect the load cells in order to deactivate current limiting.

16.8 Error numbers @ "LAST_ERROR"

16.8.1 Weighing point error

Number	Display	Cause
2	in use	Weighing point is in use, e. g., by an application.
6	test active	Test is active, no weights.
7	cali active	Calibration is active, no weights.
8	no standstill	No standstill of the scale.
13	tare is active	Tare is active.
15	weight is dimmed	Weight is not legal-for-trade (<0 or >max.).
16	weight has error	Weight error.
17	scale not ready	Scale is not ready.
18	cannot tare below zero	Taring below zero is not possible.
102	timeout	Only on xBPI scales: Time limit exceeded when sending a command to the scale.
142	calibration active	During calibration, taring and zeroing is not possible.
147	no zeroset	Zeroset outside of the zero setting range is not possible.
149	Busy	The scale is currently busy with another query.
255	hardware error	Weighing point is faulty.

16.8.2 Error in the "EasyFill" application

Number	Display	Cause
0		No error.
1	fatal error	Weight error; weighing point is faulty.
2	Material ID invalid	Number <0 or >10 entered.
3	Material name invalid	Material name is invalid.
4	Set point invalid	Set point + gross value > scale end value, (B1 mode) or gross value.
5	Preset point invalid	Value > set point.
6	OVS invalid	Value > set point.
8	Neg. tol. invalid	Value > set point.
9	Pos. tol. invalid	Value > set point.
10	Sequence number invalid	Sequence number is invalid.
13	Invalid fieldbus command	Fieldbus action is invalid (e. g., simultaneous start and stop command).
15	Cannot read from eeprom	Error when reading a material entry from the hard drive memory (EARAM) → hardware error
16	Cannot write to eeprom	Error when writing a material entry to the hard drive memory (EARAM) → hardware error
17	Action not allowed	Fieldbus action is not permitted. Example: Starting filling during an ongoing filling process or starting filling when querying the system setup.
18	Weight unit of material invalid	The unit of the weighing point does not match the unit of the material.

17 Technical data

17.1 Note on using "free software"

The firmware on the PR 5230 device contains "free software" that is licensed under the

- GNU General Public License (GPL) Version 2, June 1991, and
- GNU Lesser General Public License (LGPL) Version 2.1, February 1999.

This "free software" developed by third parties is copyrighted and is provided free of charge. The license terms and conditions of Free Software Foundation, Inc. in English are included in the delivery of the device. The source text for the terms and conditions can be found on the CD-ROM included.

17.2 Decoding the serial number

30 252 00015		
30	252	00015
Location no.: 30 = Hamburg	Code for the year/month: 252* = April 2010	Current number

* Is increment according to the year group table of Minebea Intec.

17.3 General data

Note:

For further technical data, refer to the additional information Option WE1.

The following characteristics are valid after a warm-up time of at least 60 minutes (reference temperature 23 °C).

17.3.1 Backup for date/time

The lithium battery for backing up the date/time chip is activated before the instrument leaves the factory.

Lifespan	Device continuously connected to mains voltage	up to 10 years
	Device not connected to mains voltage for some time (e.g. in storage)	up to 7 years

17.3.2 Supply voltage connection 230 V AC

Supply voltage	$U_{AC} = 100 \text{ to } 240 \text{ V}$	+10%/-15%, 50/60 Hz
Max. power consumption	12 W/16 VA	
Primary fuse	2 × 3.15 AT; 250 V; IR 1500 A; 5 × 20 mm; e.g.: Schurter: SPT5 × 20, order number: 0001.2509	

17.3.3 Supply voltage connection 24 V DC

Supply voltage	$U_{DC} = 24 \text{ V}$	-15%/+20%
Max. power consumption	14 W	
Primary fuse	2 × 3.15 AT; 250 V; IR 1500 A; 5 × 20 mm; e.g.: Schurter: SPT5 × 20, order number: 0001.2509	

17.4 Effect of ambient conditions

17.4.1 Ambient conditions

Temperature range	Reference temperature	23 °C
	Ambient temperature for operation	-10...+50 °C
	Ambient temperature in Ex areas	-10...+40 °C
	Power-on temperature	0...+50 °C
	Limits for storage/transport	-20...+70 °C
Moisture	<95%, non-condensing (acc. to IEC 60068-2)	
Protection class	Housing: IP65	
Height	<2000 m	

17.4.2 Electromagnetic Compatibility (EMC)

All data in compliance with NAMUR NE 21, EN 45501 and EN 61326.

Housing	High frequency electromagnetic fields (80...3000 MHz)	EN 61000-4-3	10 V/m
	Electrostatic discharge (ESD)	EN 61000-4-2	6/8 kV
Signal and control lines	Fast transients (burst)	EN 61000-4-4	3 kV
	Peak voltages (surge) 1.2/50 μs	EN 61000-4-5	2 kV
	Conducted disturbances by high frequency coupling (0.15...80 MHz)	EN 61000-4-6	10 V
Mains inputs	Fast transient disturbances (Burst)	EN 61000-4-4	3 kV
	Peak voltages (surge) 1.2/50 μs	EN 61000-4-5	1/2 V
	Conducted disturbances by high frequency coupling (0.15...80 MHz)	EN 61000-4-6	10 V
	Voltage dips	EN 61000-4-11	0/40/70% 20/200/500 ms
	Mains failure link	EN 61000-4-11	5 s

17.4.3 RF interference suppression

Interference emission		pursuant to EN 61326, Limit class A, for industrial areas



17.5 Connecting cables

Length of the connecting cable between junction box and instrument

Cable type	PR 6135, PR 6135A	max. 500 m – length of the load cell cable
------------	-------------------	--

Length of the connecting cable between weighing platform and instrument

Cable type	LiYCY	max. 500 m
------------	-------	------------

17.6 Mechanics

17.6.1 Design

Metal housing made of stainless steel with door, protection class IP65.

17.6.2 Weights

Net weight	6 kg
Shipping weight	7 kg

17.7 Documentation on the CD included

The documents and manuals listed in the appendix (see Chapter [18.3](#)) can be found on the PR 5230 CD.

18 Appendix

18.1 Spare parts

18.1.1 Weighing electronics board

Spare part no.	Spare part description
5312 218 58011	AD converter, fitted

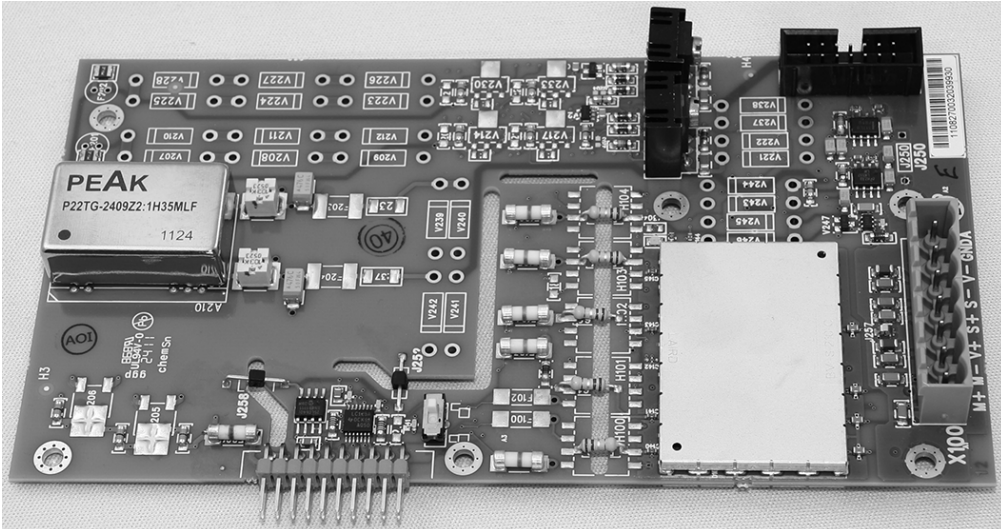

18.1.2 Display board

Spare part no.	Spare part description
5312 130 98006	Display PCB

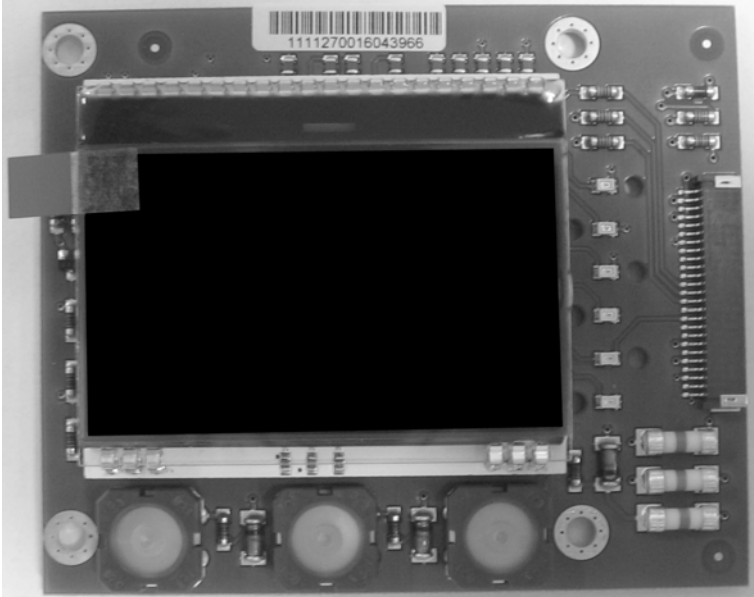

18.1.3 Fuses/accessory kits

Spare part no.	Spare part description
5312 253 28007	Fuse 3.15 A T 250 V 5x20
5312 505 48021	Accessory kit glands
5312 505 18016	Accessory kit seal screw joint
5312 321 28051	Accessory kit cables
5312 264 48018	Accessory kit connectors
5312 264 48008	5-pin connector

18.2 Test connector

for the RS-232 interface

Pin assignment

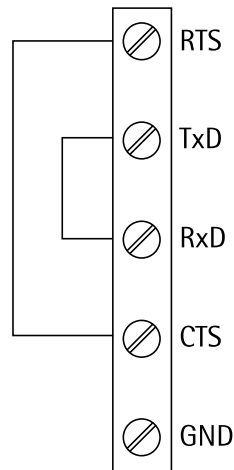

for the RS-485 interface

Pin assignment

Switch setting

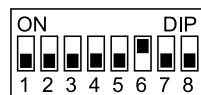
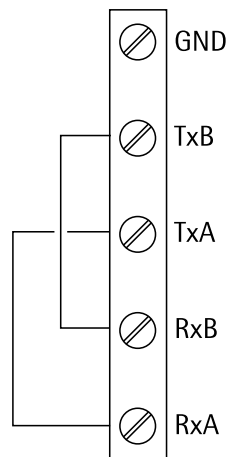

- S1 = OFF
- S2 = OFF
- S3 = OFF
- S4 = OFF
- S5 = OFF
- S6 = ON
- S7 = OFF
- S8 = OFF

18.3 Certificates

The NMI TC7959 and T11379 metrological certificates will no longer be available for newly installed systems as of 11/22/2022. Revocation of the certificates mentioned has no effect on systems that were assessed for conformity prior to 11/22/2022 (right of continuance).

Ser. no.	Description	Document no.
1	EU-Declaration of Conformity	MEU17037
2	Declaration of Conformity	MDC17004

The documents listed in the table can be found on the PR 5230 CD.

Published by
Minebea Intec GmbH | Meiendorfer Strasse 205 A | 22145 Hamburg, Germany
Phone: +49.40.67960.303 | Email: info@minebea-intec.com
www.minebea-intec.com

